



Answering the Call: Your Role in the Cyber-Spectrum Fight

CySER Summer Workshop 2026

Mr. Chester “CJ” Maciag
VICEROY National Director
Director Cyber-Spectrum Academic Engagement
Quantum – Battlefield Information Dominance (Q-BID)
OUSW(R&E), OASW(CT), D(AT)





VICEROY National Director



Mr. Chester “CJ” Maciag

Director for Cyber and Spectrum Academic Engagement, OUSW(R&E)

Current Role & Responsibilities

Leads talent pathway programs for future cyber and spectrum leaders for the Department of Defense. Assists in aligning and accelerating DoD cyber talent programs and scholarships to maximize efficiency.

Experience

OUSW(R&E):

Acting Principal Director for Cyber.

Acting Director for C5ISREW, directing \$4B annually in defense-related programs.

Air Force Research Laboratory (30 years):

Served for 30 years, culminating as the acting principal advisor to the chief scientist.

Utica University (20 years):

A recognized leader in cybersecurity education.

Accomplishments & Affiliations

- Recipient of the 2018 SANS Difference Makers in Cybersecurity award.
- Co-author of 12 papers in information and network security and a book chapter in digital forensics.
- Member of the Military Cyber Professionals Association and the Association of Old Crows.
- U.S. Coast Guard Certified 50-Ton Near-Coastal Master Captain.



USW(R&E) – DoW’s Chief Technology Officer

Core Responsibilities of OUSW(R&E)

Technology and Innovation

- Serve as the principal advisor to the Secretary of War on all research, engineering, and technology development, championing innovation to maintain the U.S. military's technological advantage.

Policy and Supervision

- Establish policies for and supervise all defense research, engineering, prototyping, and testing programs, unifying these efforts across the entire Department of War.

Speed and Efficiency

- Drive innovation with a focus on speed and efficiency by welcoming new and innovative companies to find asymmetric solutions and implementing private-sector best practices to streamline operations.



6 Critical Technology Areas

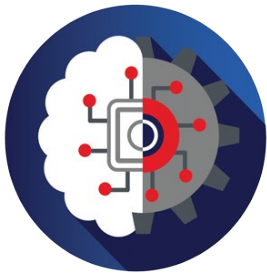

Applied Artificial Intelligence



Biomanufacturing



Contested Logistics Technologies



Quantum – Battlefield Information Dominance



Scaled Hypersonics

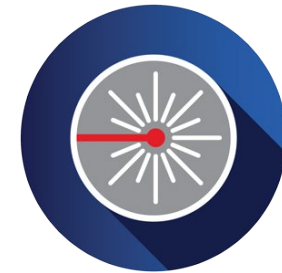

Scaled Directed Energy

Q-BID: Critical military technology focus aimed at leveraging quantum mechanics for superior communication, Position, Navigation, and Timing (PNT), and electromagnetic spectrum operations



Quantum and Battlefield Information Dominance (Q-BID)

Q-BID enables U.S. military dominance in the information environment by integrating Cyber, Electronic Warfare, Communications, Sensing, and AI to deliver tactical and strategic decision advantage.

Key Q-BID Operational Objectives

- **Decision Superiority** - Faster, more effective command and control through integrated operational picture
- **Information Environment Control** - Active degradation, disruption, and manipulation of adversary systems
- **Operational Resilience** - Hardened, redundant networks ensuring continuity under attack
- **Multi-Domain Integration** - Coordinated effects across tactical to strategic levels (EW, Cyber, Sensing, Intel, Comms)

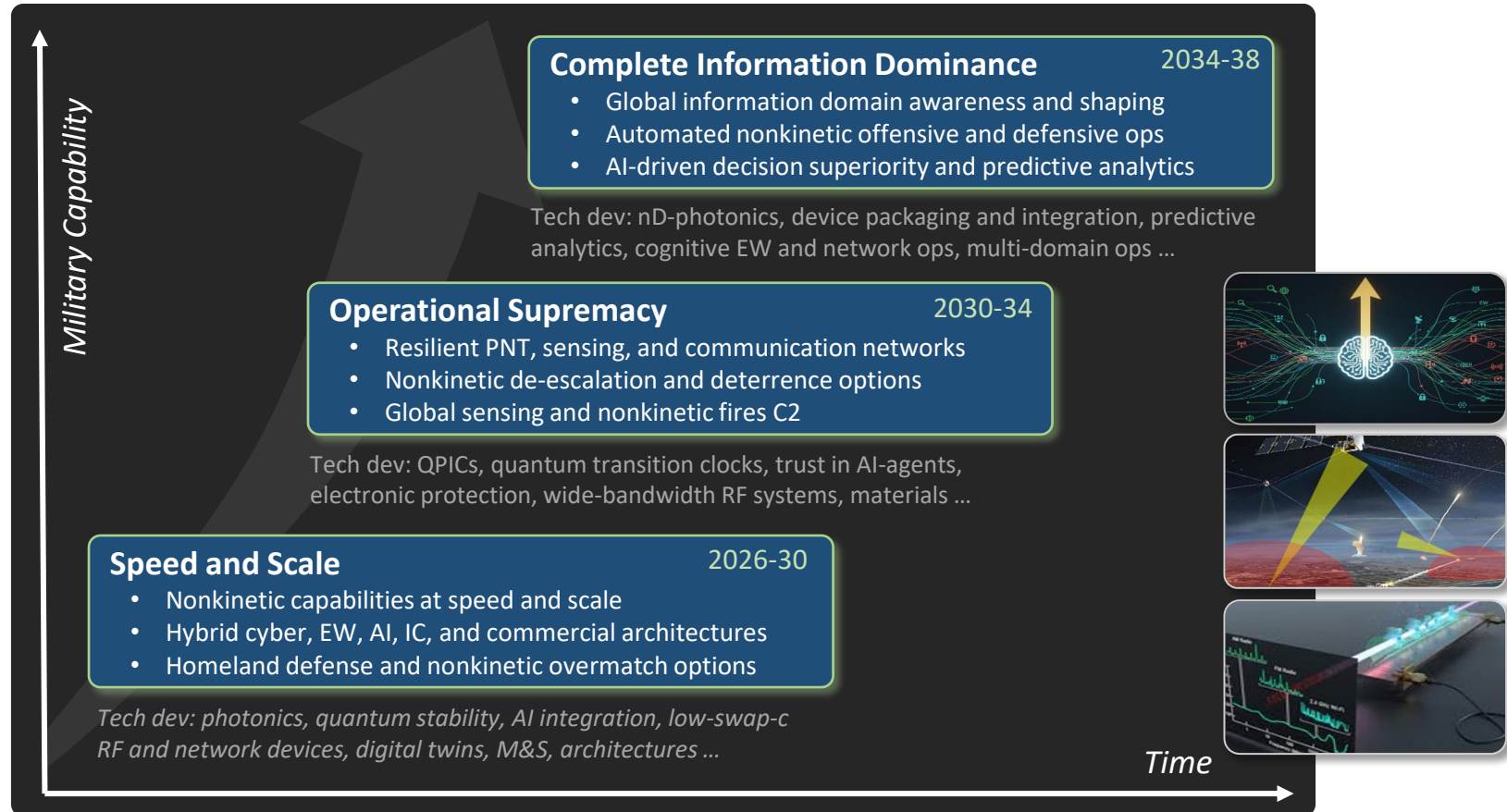

EW – Electronic Warfare AI – Artificial Intelligence
 PNT – Position, Navigation, and Timing IC – Intelligence Community
 M&S – Modeling and Simulation RF – Radio Frequency
 C2 – Command and Control QPIC – Quantum Photonic Integrated Circuits



Cyber-Spectrum-Information Operational View

AI/ML Key to Increasing Speed, Reducing Complexity, and Enhancing Mission Robustness

State of Play

- Cyberspace, electromagnetic spectrum, and information underpin virtually all physical-world operations
- The public/human is the target of all Diplomatic, Informational, Military, and Economic instruments of power
- Cyber, EMS, and Info effects historically were afterthoughts in system design or mission/effects planning

End-State for National Security and Defense:

- Evolve non-kinetic engagement from a supporting to a supported domain of operations.
- Characterize and seamlessly integrate cyberspace, EMSO, and OIE situation awareness and operations
- Fluidly deliver effects across all domains of operation in all phases of warfare

Future Readiness for National Security:

- Workforce readiness initiatives that create capable military, civilian, and industrial base cyber and electromagnetic spectrum leaders in technology and operations

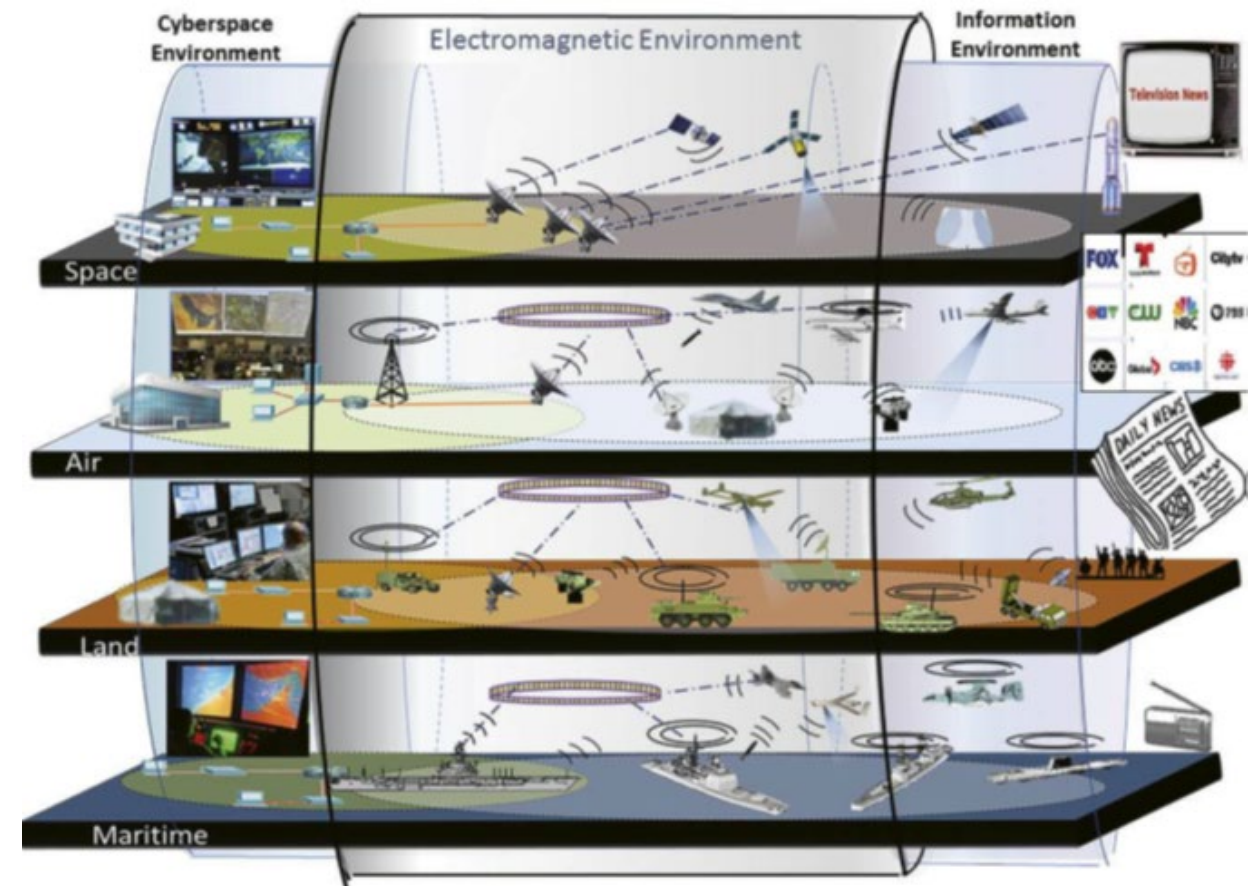



Cyber Domain Challenges in the Age of AI



Contested

The adversary is AI-augmented, capable of automated and adaptive attacks at machine speed.



Dynamic

AI accelerates the pace of change, creating and discovering new vulnerabilities faster than human defenders can track



Held in Common

Open-source AI models create a dual-use dilemma, empowering both defenders and adversaries with the same powerful tools.



Ubiquitous

AI is being embedded everywhere, introducing new attack surfaces like data poisoning and adversarial manipulation of models.



The Invisible Front Line: Hardware, Supply Chains, & Data

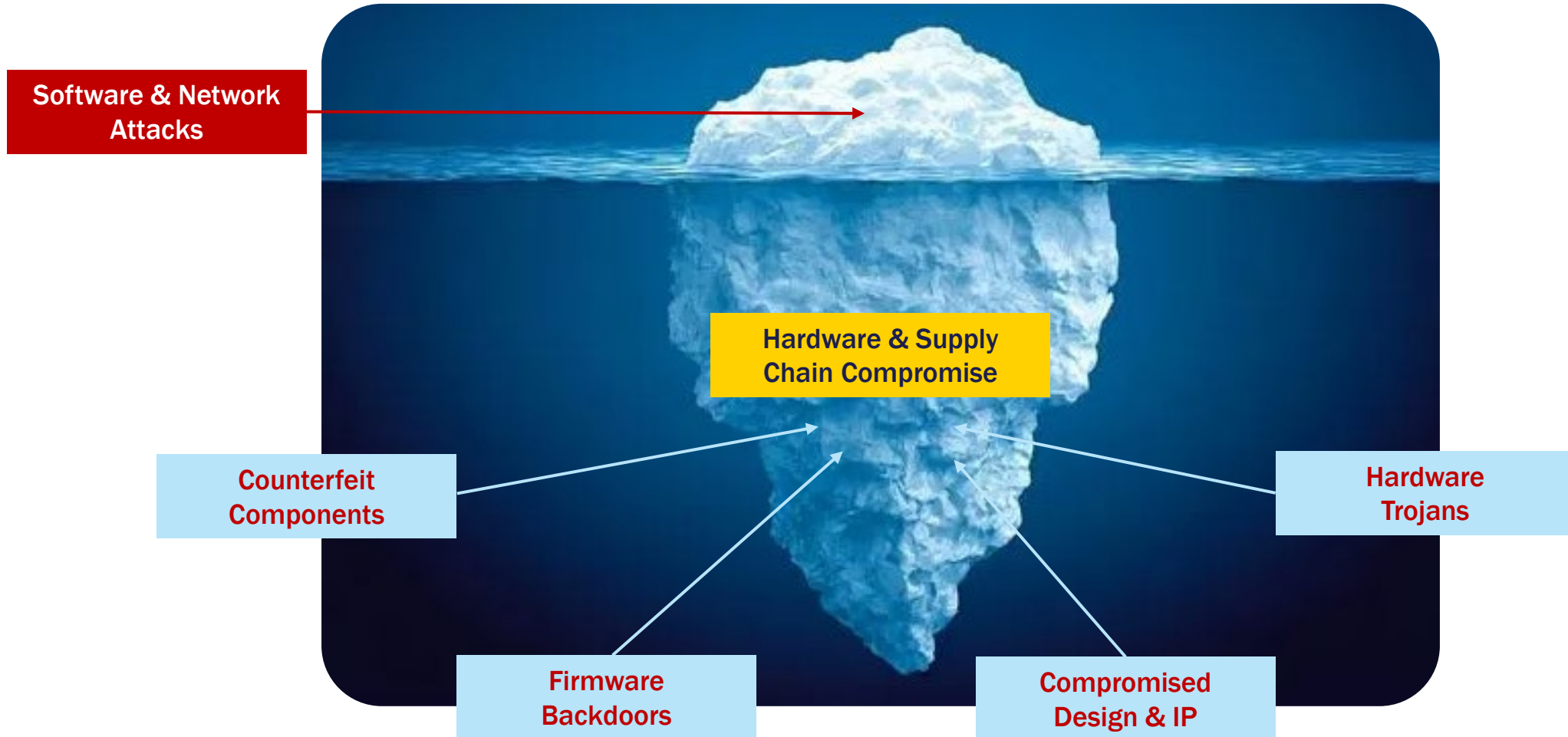



Supply Chain Dependencies: Chips and Batteries

U.S. Microelectronic Manufacturing Base Has Been Outpaced by Asia

1990 - 37% 2030 - 10%

Global manufacturing capacity by location (%)

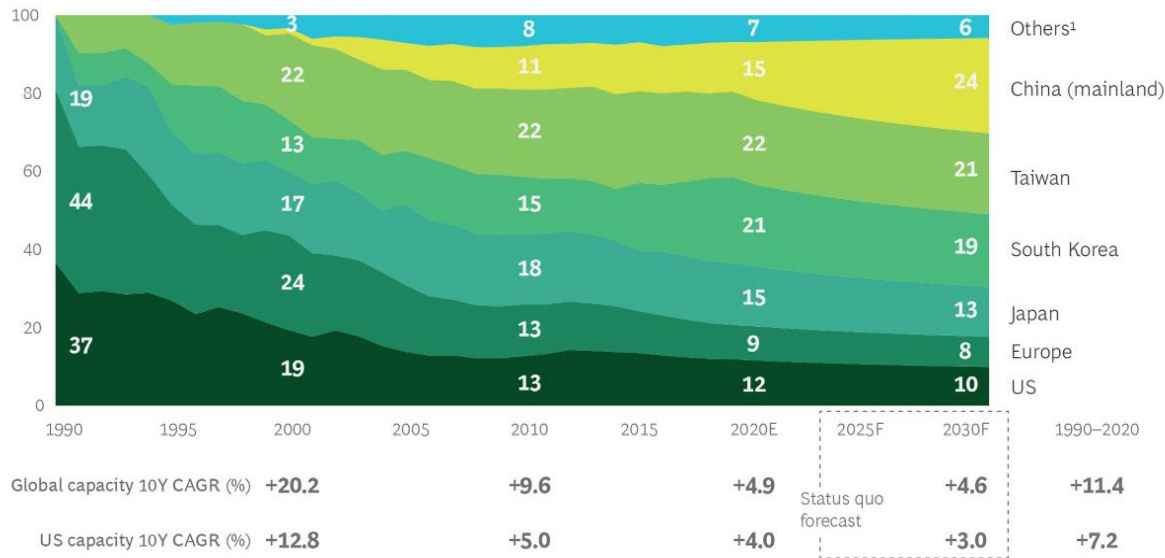

Sources: VLSI Research projection; SEMI second-quarter 2020 update; BCG analysis.

Note: All values shown in 8" equivalents; excludes capacity below 5 kwpm or less than 8".

¹ Includes Israel, Singapore, and the rest of the world.

China Supply Chain Dominance in Li-Ion Manufacturing Capacity

Rank	Country	2021 Li-ion manufacturing capacity (GWh)	% of World Total
#1	China	558	79.0%
#2	U.S.	44	6.2%
#3	Hungary	28	4.0%
#4	Poland	22	3.1%
#5	South Korea	18	2.5%
#6	Japan	17	2.4%
#7	Germany	11	1.6%
#8	Sweden	4	0.6%
#9	UK	2	0.3%
#10	Australia	1	0.1%
N/A	Rest of the World	1	0.1%
N/A	Total	706	100.0%



Cargo Vessel Traffic Density Maps

50% of World's Cargo Passes Through the Taiwan Strait // 20% of Oil Through Strait of Hormuz

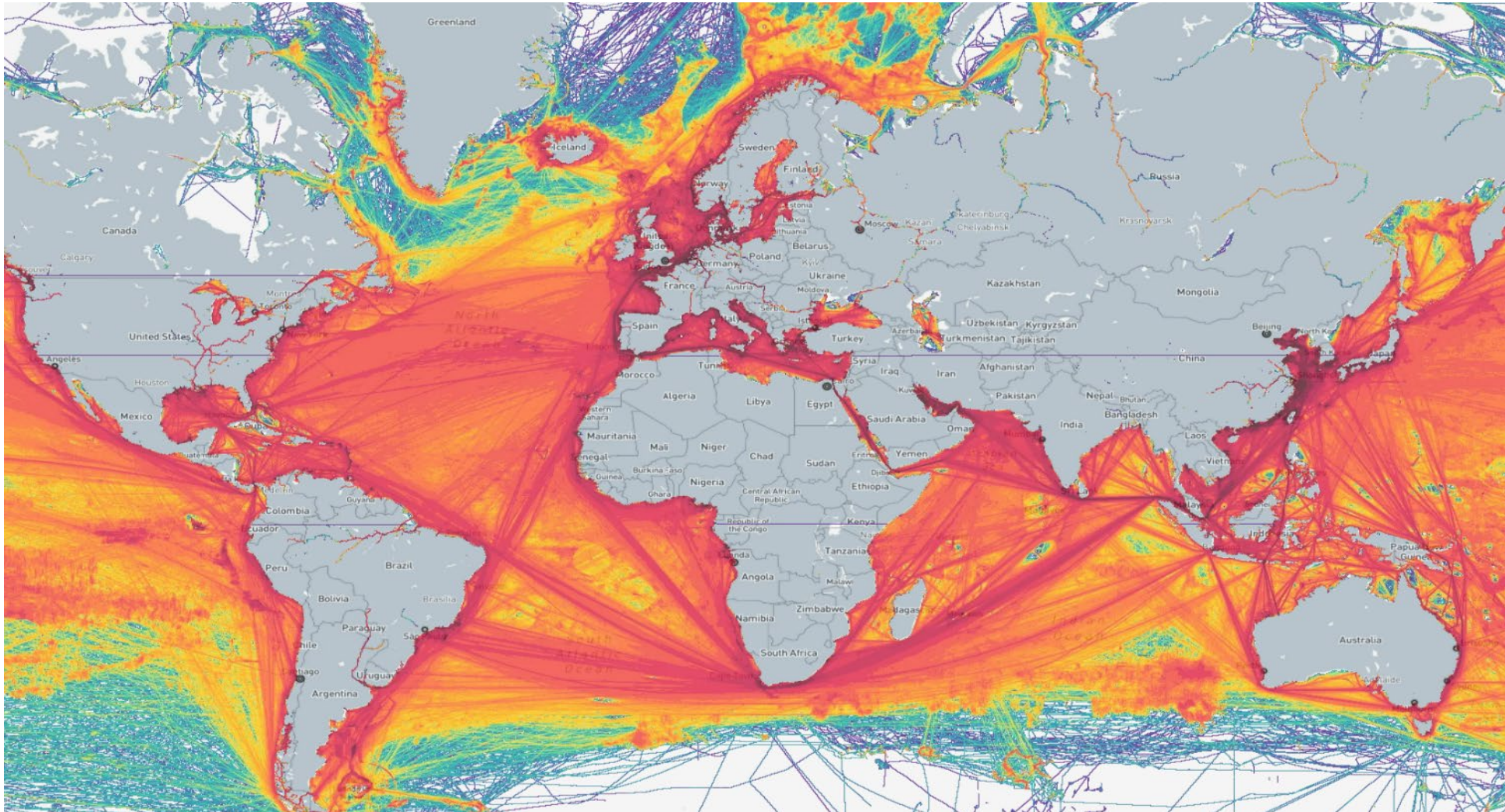

Source: Taipei Times (May, 2024). <https://www.taipetimes.com/News/taiwan/archives/2024/05/14/2003817836> // Photo Source: Marine Traffic (2024). <https://marinetraffic.com>

Distribution A: Approved for Public Release



Our Cars are Rolling Data Centers

Common Foundational Technology as Military Vehicles

Modern Vehicle Data Network Complexity

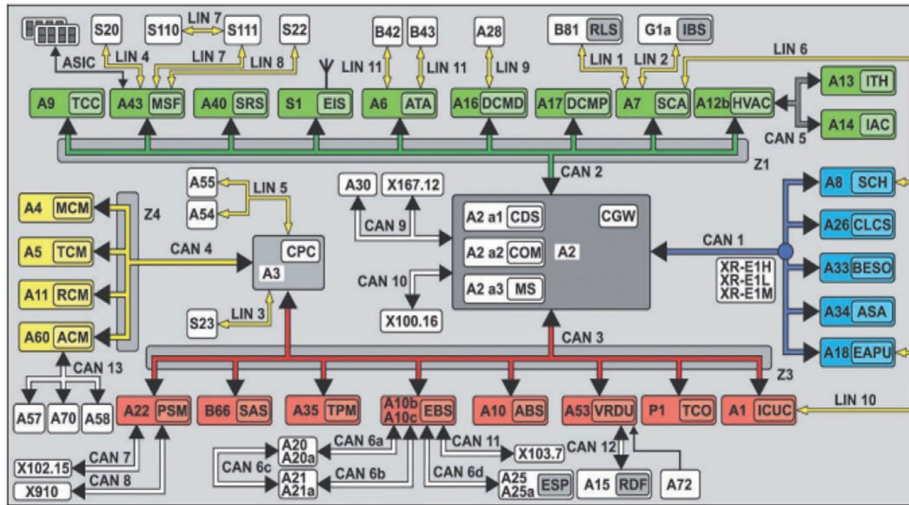

- 1 Modern Vehicle with
- 13 CAN Data Buses
 - 11 LIN Data Buses
 - 53 Electronic Control units

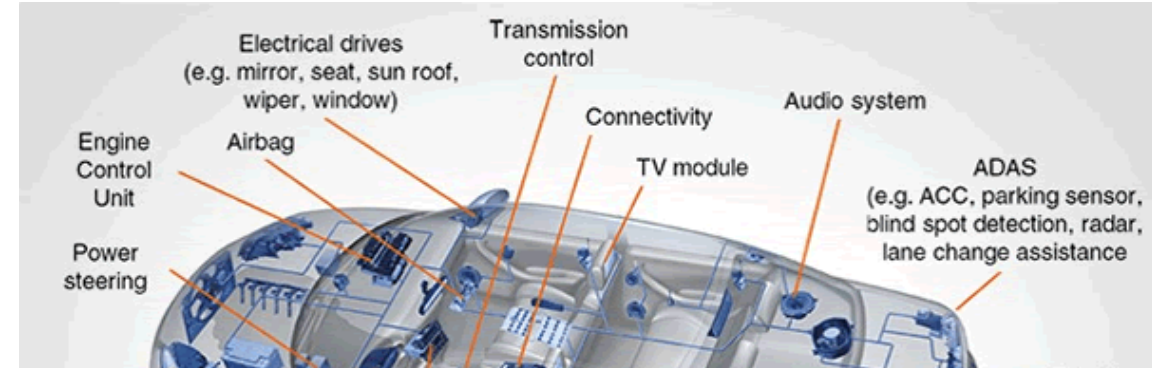



The Converged Battlefield is Here



China

Undermines U.S. Competitive Advantage through Cyberespionage

Most Active, Expects Conflict



Russia

Most Aggressive Nation in Information Domain

Very Sophisticated, Undeterred



Iran

Intensifies Cyber Ops under U.S. Pressure, Demonstrated Willingness to Attack

Employs Destructive OPS, Moderate Capabilities



North Korea

Exploits Cybercrime to Evade Sanctions, Demonstrated Willingness to Attack

Ambitious and Volatile, Moderate Capabilities



VEO

Leverages Cyber Access to Enable Critical Operations

Least Capable, but Globally Interconnected

Adversaries are increasing in sophistication, capability, and capacity

2012-2013

2014-2015

2016-2017

2018-Present

Iranian DDoS Campaign against U.S. financial Institutions

China Exfil of OPM records
Iran data destruction against U.S. casino
North Korea attack against Sony Pictures

Russia influence Ops in U.S. Elections
Russia compromises U.S. electric grid

China, Russia, Iran COVID influence operations
Russia influence Ops in U.S. Elections
Iranian cyberattacks against U.S. Interests
SolarWinds

Early 2010s

Cyber theft of U.S. intellectual property ~\$300B/yr (2000 est)

2020s

Recent Trends

- Quickly Evolving Tactics, Techniques, and Procedures
- Rapid Leverage of Commercial Technologies
- Employment of Artificial Intelligence to Reduce Complexity and Increase Speed



What Cyber-Spectrum Really Means

THE SITUATION >

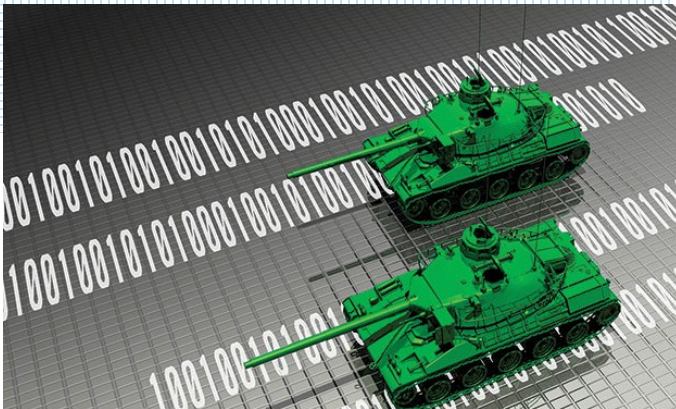

The electromagnetic spectrum is the new physical battlefield for cyber operations.

Winning requires the integration of Cyber, EMS, and OT/IT into a single, unified domain.

THE CHALLENGE >



Adversaries are actively exploiting this convergence to bypass our traditional, siloed defenses.

We must cultivate multi-disciplinary talent to fight and win in this converged battlespace.

THE DRIVERS >



- FY19 NDAA Section 1640
- DoW EMS Superiority Strategy 2020
- DoW STEM Strategic Plan for Fiscal Years 2021-2025
- DoWM 8140.03 - Cyberspace Workforce Qualification and Management Program
- FY24 NDAA Section 1531

[Department of War Announces New Cybersecurity Risk Management Construct 24 SEPT 2025](#)



The National Talent Gap

**MISSION
DEMAND**

THE READINESS GAP

**TALENT
SUPPLY**

Demand vs. Reality: A Deepening Deficit

The need for mission-ready cyber and spectrum talent is growing exponentially, while our supply pipeline remains linear and slow. This isn't just a gap; it's a chasm.

The Pipeline Problem: Too Slow, Too Siloed

Our traditional education and training systems take years to produce graduates, who often still lack the specific, multi-disciplinary skills needed on Day One.

The Operational Cost: Starving the Front Lines

Operational units are hungry for real capability *now*. This talent deficit means we are leaving our warfighters under-equipped in the most critical modern battleground.

The National Imperative: Talent = Readiness

This is more than a workforce issue; it's a national readiness crisis. The talent cultivated in this room is the most vital strategic asset we have to close the gap.



VICEROY | ELITE Talent. Mission Ready.

Answering the call

WHY: More than 19,000 cyber positions remain open within DoW. Need to enhance the talent pipeline of mission-capable ROTC and civilian graduates to solve future cyber and electromagnetic-spectrum national security challenges.

WHAT: A mission-focused cyber-spectrum leadership development pathway, accelerating talent through foundational skills, experiential learning, and operational application.



VICEROY answers the call for defense readiness by increasing the number of new and upskilled mission-capable professionals available to fill critical cyber-spectrum research and operations positions within the DoW and vital industries who are able to contribute on Day One.

VICEROY Scholar Growth by Fiscal Year

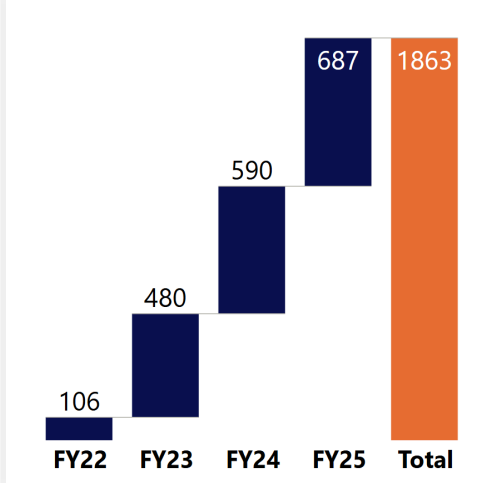

Notable Achievements to Date:

- Partnered with 46 Post-Secondary Institutions nationwide forming a single cohesive VICEROY Virtual Institute
 - 1800+ VICEROY Scholars to date with approximately 680 in the FY26 pipeline
 - 235 VICEROY ROTC Cadets, 70 of which were also interns - 67 affiliated ROTC units
 - Over 200 scholars have received industry certifications aligned with DoD 8140
 - VICEROY Scholar designation tracks Army Cyber Leadership Development Program criteria
- 174 VICEROY Scholars pursued 162 DoW-related academic projects
 - 54 projects were submitted for publication in peer-reviewed journals
- 25 DoW organizations harness VICEROY interns; spans all three Services, Components, and COCOMs
 - Approximately 200 interns placed each summer; net ROI for work performed at mission-partner site



The VICEROY Model

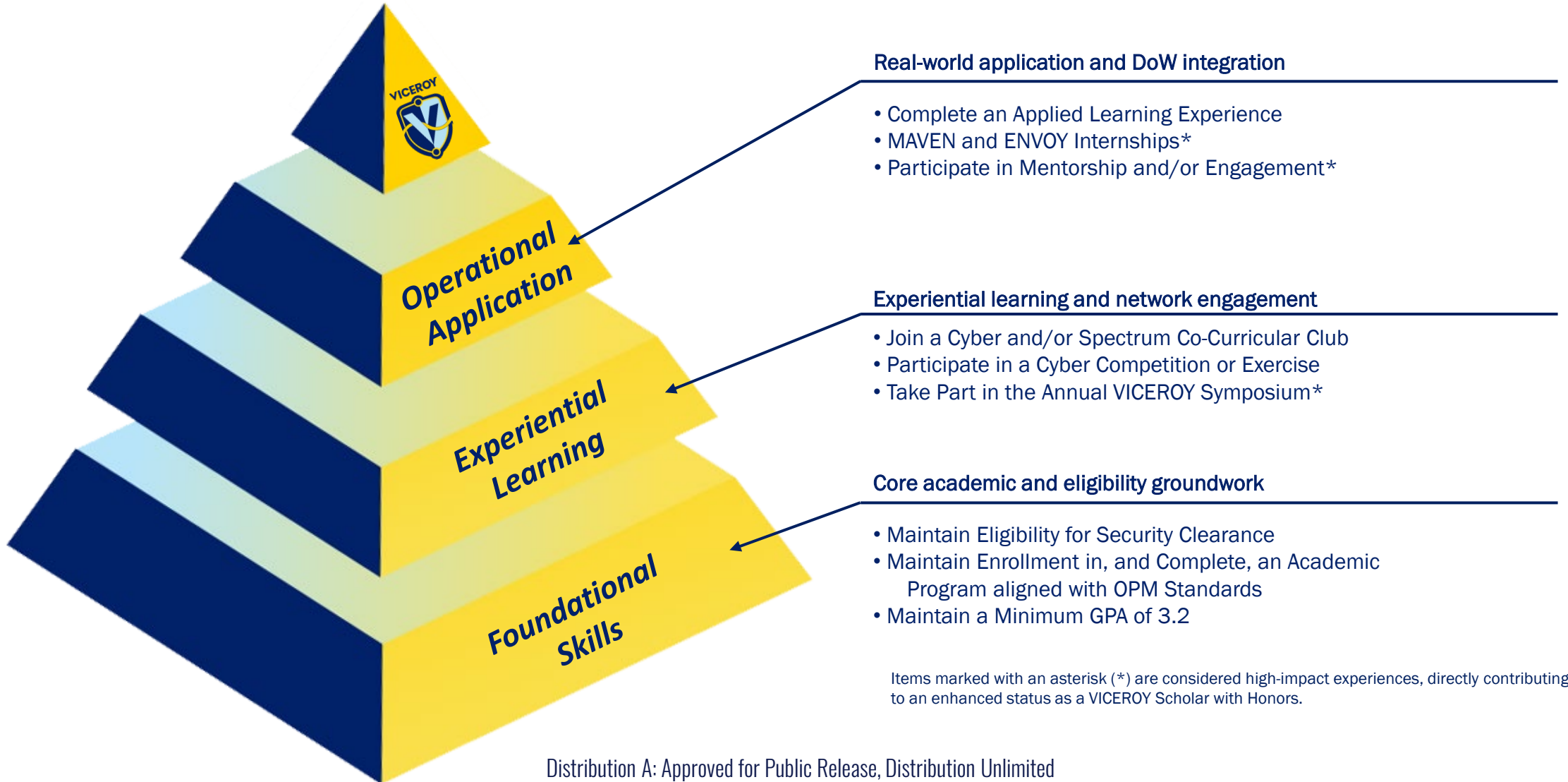

From Skills Challenges to Combat-Capable Forces



Augusta



Northeastern

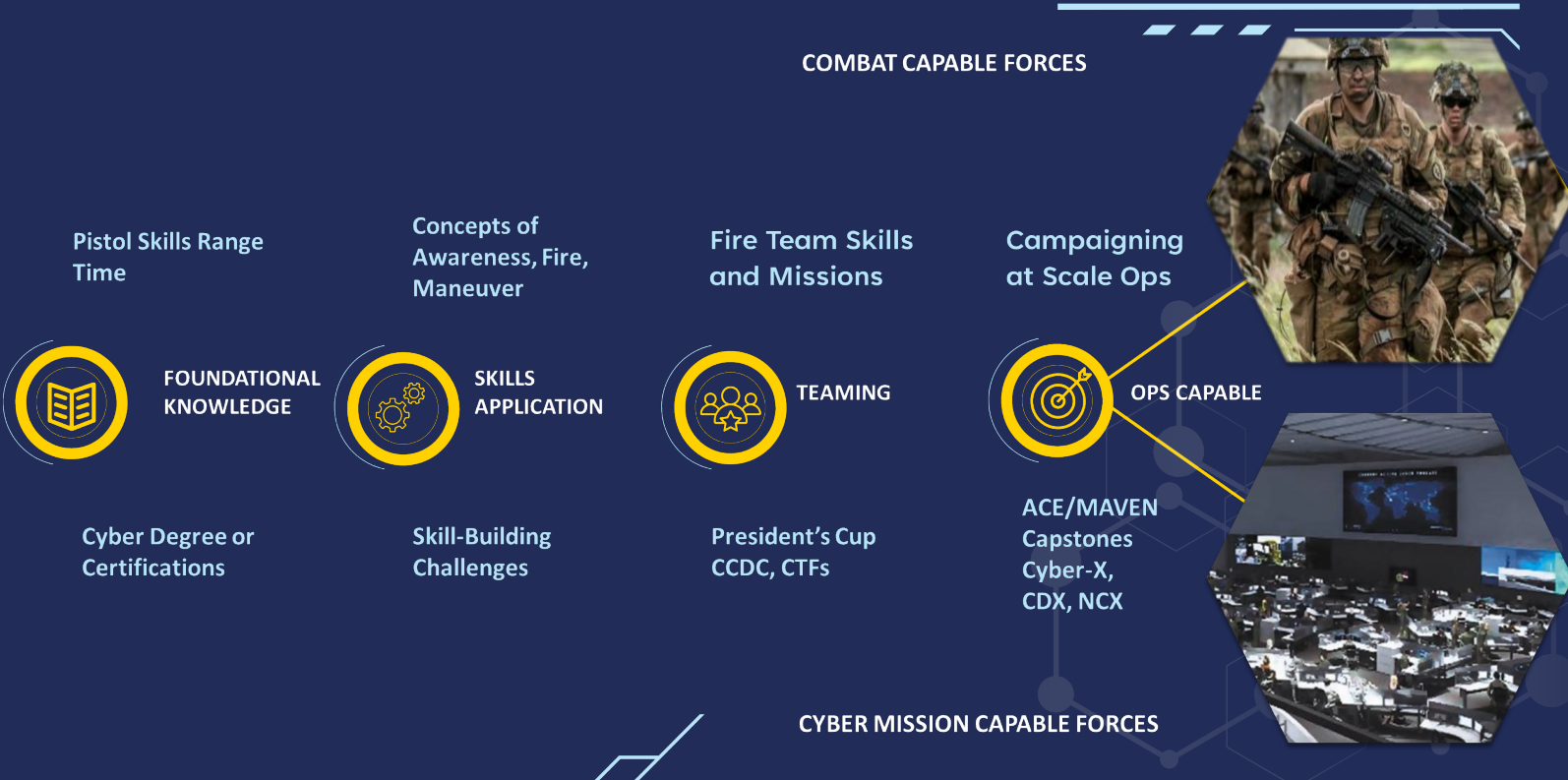



VICEROY



VICEROY



Hawaii National Guard (HING)

The VICEROY MAVEN, Powered by P3I internship program brought an outstanding team consisting of Kenneth, Allen, and Upu to the HING JOC. Their performance was truly exceptional. They demonstrated remarkable initiative and took ownership of a complex task, delivering a working product that proved invaluable to the JOC.

The program they developed to improve rapid situational understanding for fires holds significant practical value within the JOC. I am confident that the HING would greatly benefit from maintaining a continued partnership with P3I.

- MAJ Dax Bajema, OIC, HING Joint Operations Center



ENHANCING EMERGENCY RESPONSE CAPABILITY



ALAN AQUINO
BS Cybersecurity
UHWO, May 2025



KENNETH DE GUZMAN
BS Computer Science
UH Manoa, May 2025



UPUMONI LOGOLOGO
BS Data Science
Chaminade, May 2025

MENTORS:
Major Dax Bajema, JOC Operations
Major Earl Tsuneyoshi, Joint Plans Officer

HAWAII NATIONAL GUARD

Assessing a significant All Hazards incident requires real-time data collection and a technical framework to aggregate and analyze data to support decision making in the event of an emergency.

The VICEROY MAVEN, Powered by P3I team developed a program to HING to improve rapid situational understanding during fires.

ACCOMPLISHMENTS

- ✓ Studied the user requirements and tools available to develop a solution
- ✓ Designed, developed, and improved a web dashboard to visualize data in a map
- ✓ Integrated data from local news, fire and police departments, NASA FIRMS, windy.com, AlertWest, and FlightTracker
- ✓ Enabled authenticated users to securely chat

"The program developed by the interns was used during four emergencies this summer and is more useful than applications offered by vendors."

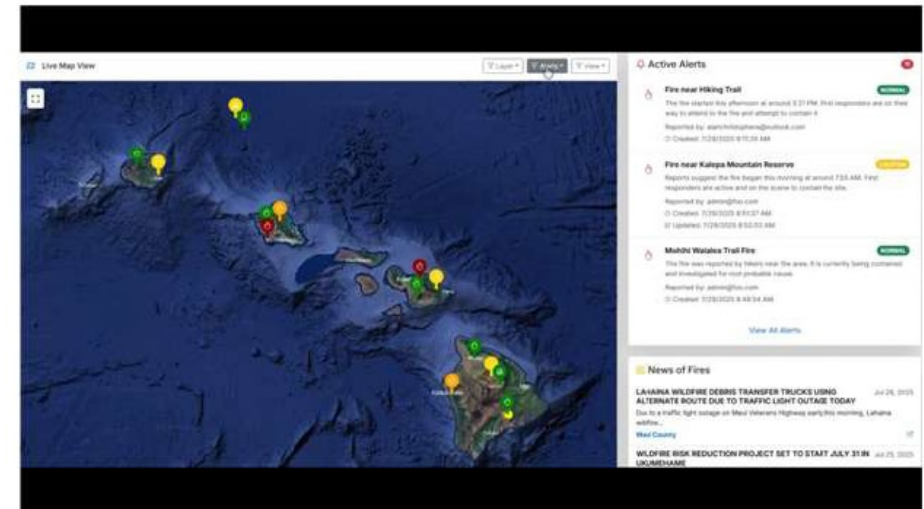
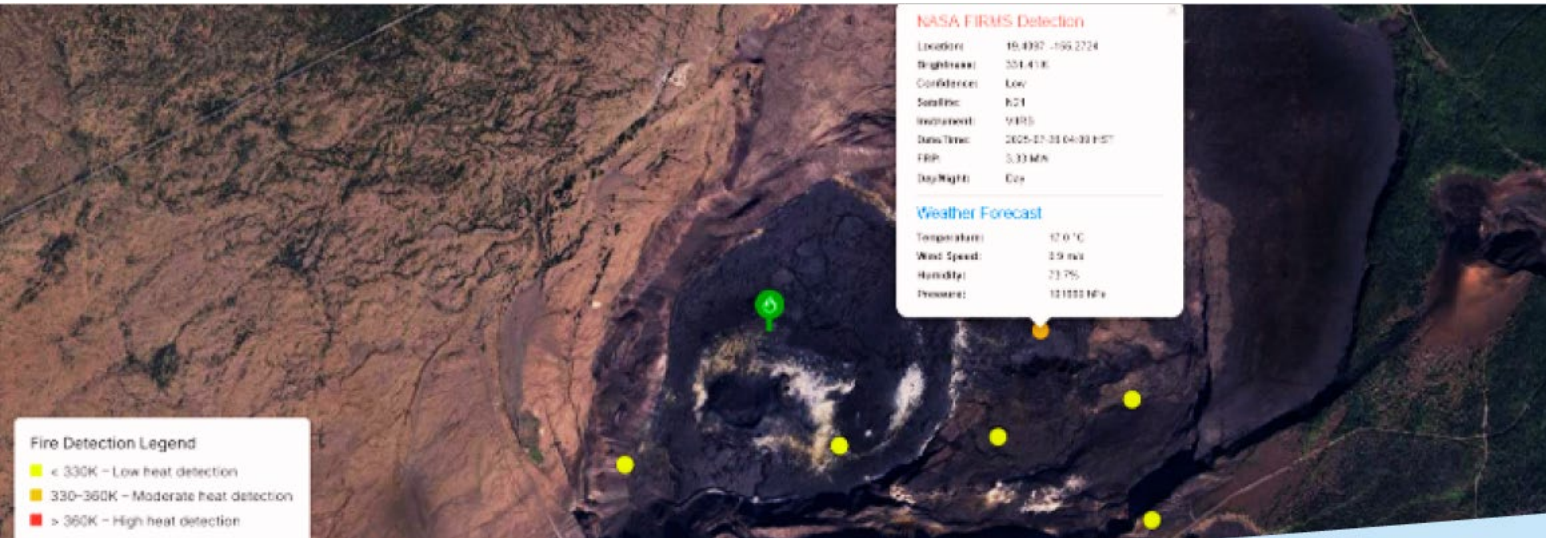



Real Mission Insights from the VICEROY Network



“VICEROY ENVOY students are not working on projects that are going on a shelf, but rather, they are working on software projects that are contributing to our real-world operational mission and increasing the survivability and effectiveness of combat aircrews.”

Col John Christianson, AF 350th SWW



“The Cadets have been amazing, they helped with logistics, range build, coordination, equipment set up, electrical engineering and much more. This has been an amazing experience, and I hope they are also enjoying their summer.”

Dr. Andre Slonopas, CIV USARMY DEVCOM ARL



“I’m still on ‘cloud 9’ after a closeout day with VICEROY interns. I want you to know that VICEROY had a huge impact on ACC, the interns themselves, and myself included, given all of the tours/bluing from F-22, T-38, F-16alert, CAOC-X, NASA x2, Ops Analysis Squadron, Point Defense Task Force, etc. Look forward to “clinging” with you on a successful Class of '25 venture and thanking you!”

John D. Matyjas, PhD, SL (DV-6), ACC



“As a Computer Science student at SUNY Albany and a VICEROY Intern, I gained invaluable exposure to DoD culture that truly shaped my career path. VICEROY deepened my understanding of the vital role scientists and engineers play in national security and inspired me to pursue a career with the DoD. Upon graduation, I’m thrilled to join Air Force Research Laboratory Information Directorate (AFRL/RI) full-time, continuing to work alongside my mentor to address the nation’s most critical challenges.”

Sharie Rhea, VICEROY Alumni



Evidence of Impact: From Academia to Mission Readiness

Proportion of Hired VICEROY Students by Institution and Employer Group

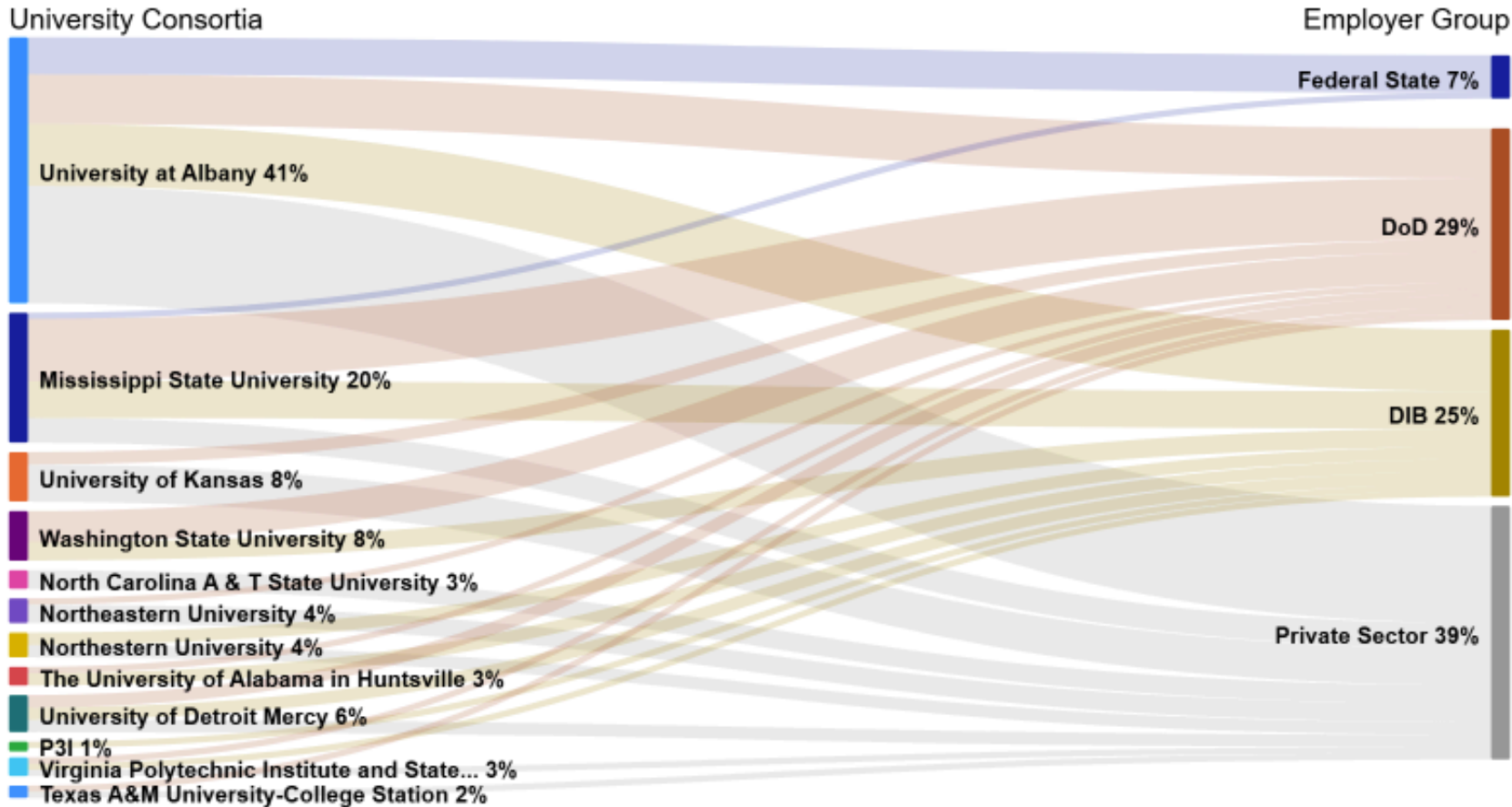

VICEROY Scholars are:

- Researching and solving real DoW challenges
- Accelerating on-boarding—Ready on Day One
- Verifiable skills & certifications

Inspiring career-changing entrepreneur Scholars within Private Sector

61% Transition Directly into Federal, State, DoW, or DIB Roles.



A Shared Mission

UNCLASSIFIED



Your mission, wherever you sit, is to ensure talent is mission ready and integrated before the fight begins.

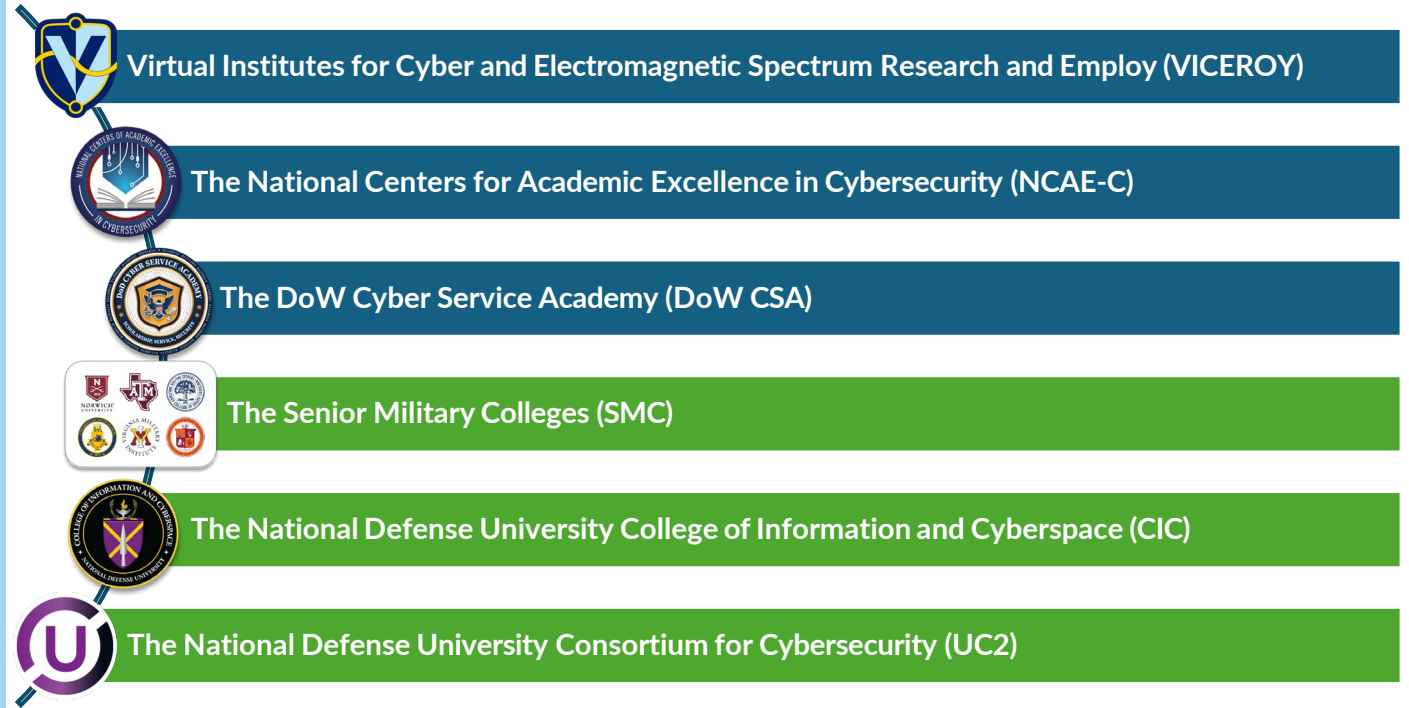

AIR FORCE



ARMY



NAVY



OPTEV



US CYBER COMMAND



USPACOM



Answering the Call



Cyber-spectrum dominance will be determined by people, not just technology.

- Every generation faces a defining challenge.
- For us, it's defending our nation in the cyber-spectrum battlespace.
- The adversary is moving fast.
- The technology is evolving faster.
- Our Talent is our greatest advantage.





UNCLASSIFIED



Questions & Answers

Thank you!





Connect & Share

UNCLASSIFIED



@VICEROYScholars



www.VICEROYScholars.org



Visit our website for news, events, access to the VICEROY Institute LMS and more!

FOLLOW, SHARE, & TAG us on Social!