



Structures/Aerodynamics

Jon Farrell, Dean Hoover, Geoff Wendt, Kyle Dorosh, Joel Johnson, Malique Perera, Joel Johnson, Ryan Blanchard, and Katlyn Struxness

Mission Statement

Design, simulate, build, test, and fly a rocket airframe that's structurally and aerodynamically sound, follows competition rules, and wins full points.

Nosecone

- Foremost section of the rocket
- Shaped to offer minimum aerodynamic resistance

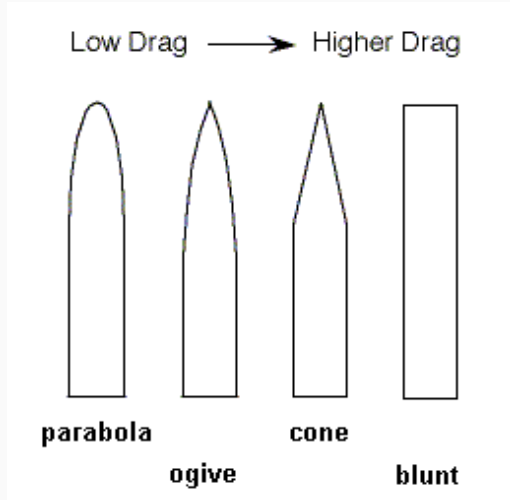

Von Karman Nose cone



Body Tube

- The outer skin-the body tube is what holds the “innards” in place and provides the main structure of the rocket
- Researched various methods of tube manufacturing
 - Filament winding
 - Pultrusion
 - Extrusion
 - Mandrel (Fluorescent bulbs!)
- Why are rockets round?



Fins

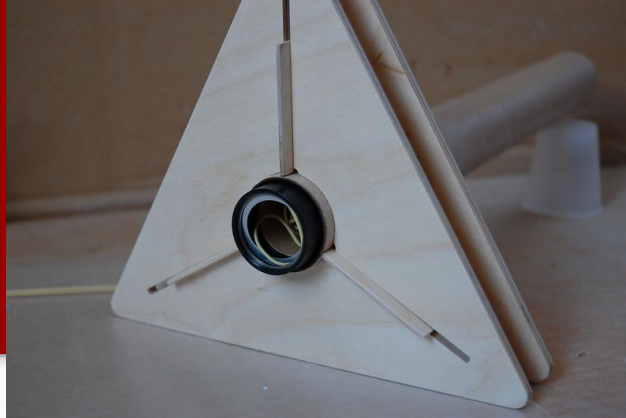

FIN DESIGNS

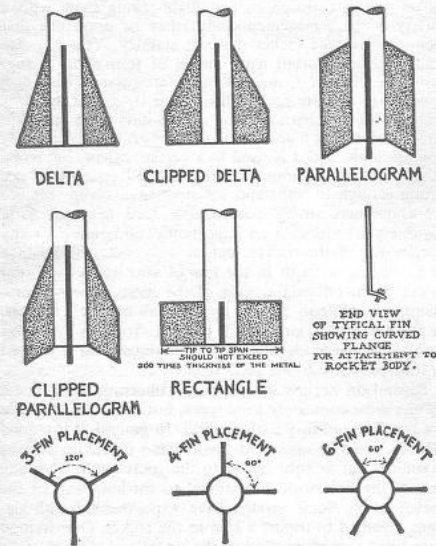

Used for stabilization of the rocket

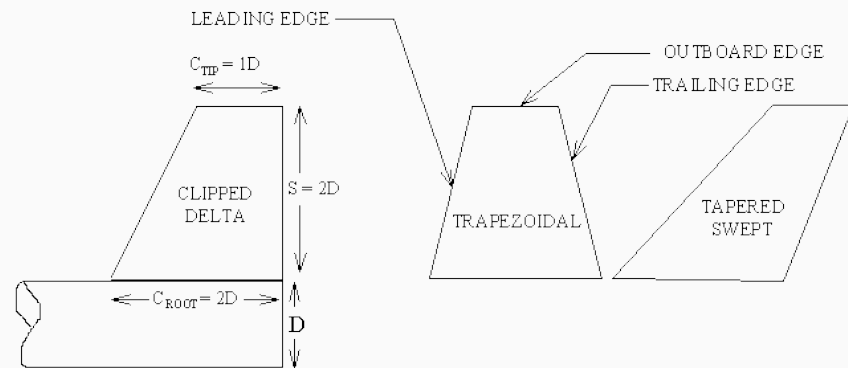
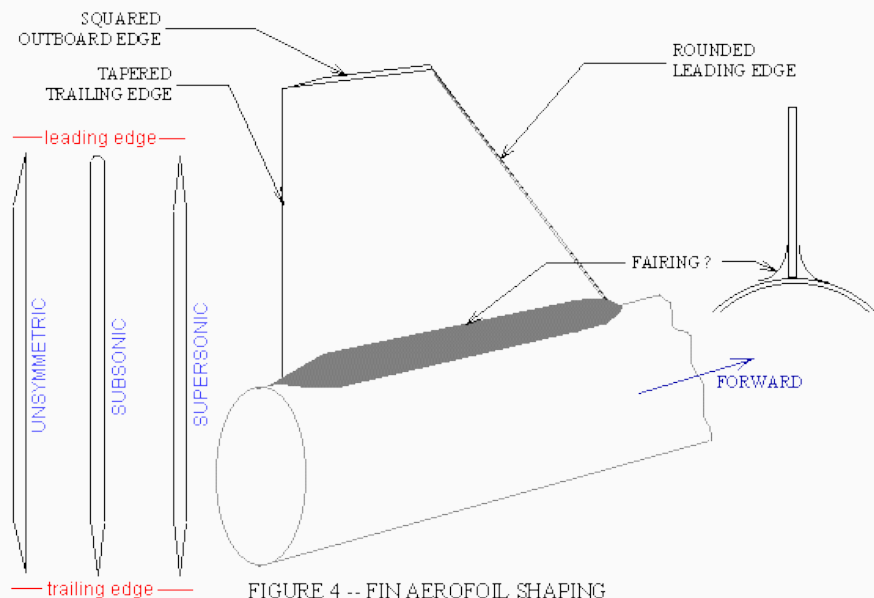

Boat Tail

- Used to reduce drag in the final portion of the rocket
- The transition from the large diameter of the rocket body cuts down on turbulence in the fin area

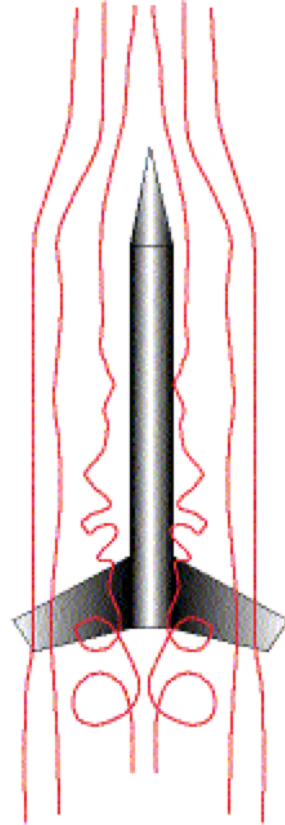

turbulence without boat tail



Bulkheads: What are they?



- Like a barrier, bulkheads are used when you need to close off or seal a section or a compartment.

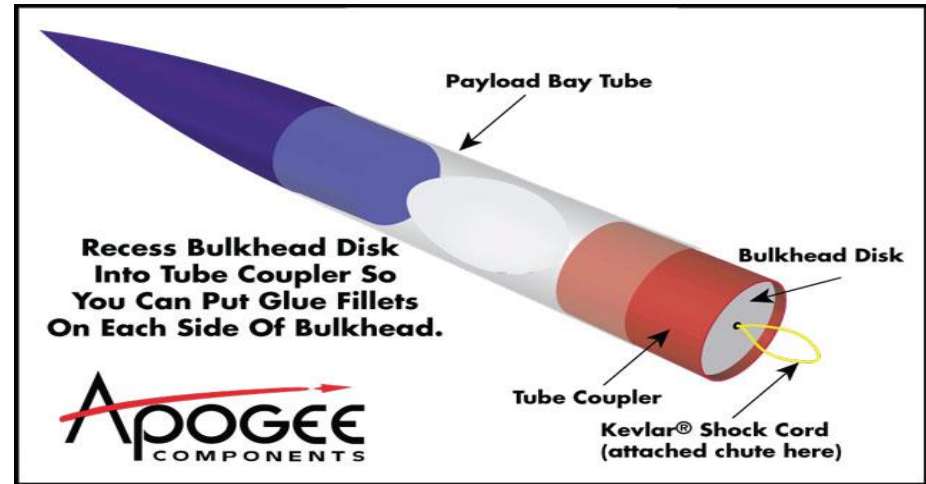

Bulkheads: What do they do?

- Bulkheads block off the air flowing through the tube, protecting the payload from the heat of the ejection charge.
- Reinforces the frame and increases the structural rigidity of the rocket.
- Anchor for parachute attachment
- Divides a barrier between the payload and parachute sections.



Couplers

- Connect different rocket at separation points
- Usually are tubes whose outer diameter matches the inner rocket body diameter

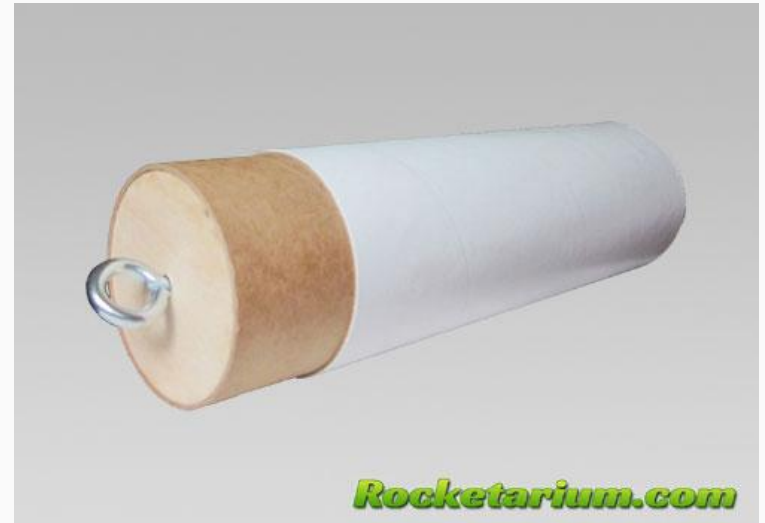

Engine Mount

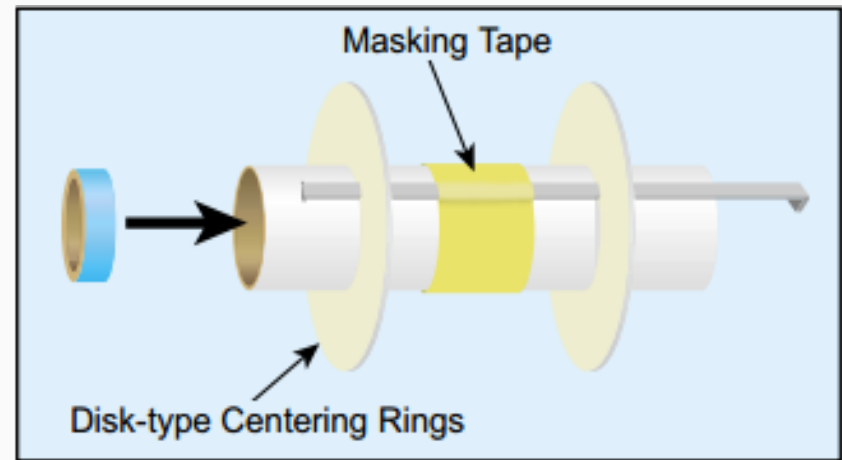
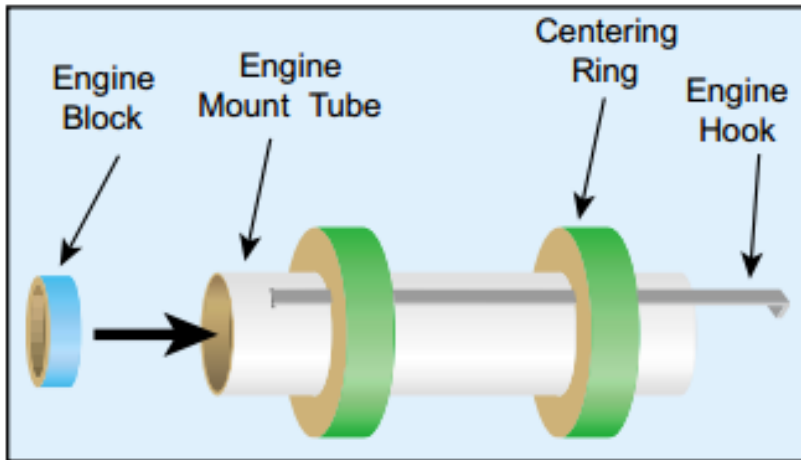
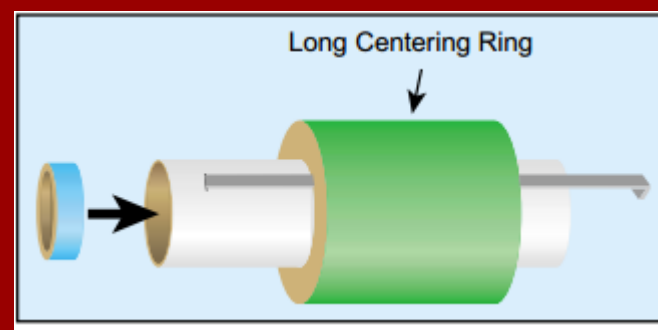

Cameras & mounts

- Cameras need viewports and mounts which would be part of structures
- Found some pictures where cameras were mounted on nosecones and in clear sections of body tubes.



Thank You!