

Rabbit Project Leader Guide

Level 3



4-H 

WASHINGTON STATE UNIVERSITY
EXTENSION

EM078E



4-H Rabbit Project

Level 3 Activities

Table of Contents

The History of Rabbits	1
Recognizing the Rabbit's Skeleton	3
Raising Rabbits in Cold Weather	7
Making a Wire Rabbit Cage	11
Making a Rabbit Carrier	13
Administering Rabbit Medicines	17
Controlling External Parasites	19
Controlling Internal Parasites	21
Common Diseases of Rabbits	25
The Rabbit's Digestive System	31
Understanding a Rabbit's Estrus Cycle.....	35
Determining Pregnancy in Rabbits	37
Raising an Orphaned Rabbit	41
When to Remate the Doe after Kindling.....	49
Determining When to Breed to Produce Rabbits for Various Show Classes	53
Formulating Rabbit Show Classes	55
Talking Like a Rabbit Judge	57
Presenting Oral Reasons	59
Scoring a Judging Class	63
Determining a Rabbit's Condition	67
Figuring Dressing Percentages and Average Daily Gain	69
Home Processing a Rabbit	71
Cutting Up and Wrapping a Rabbit Carcass	77
Caring for a Rabbit Pelt	79
Tanning a Rabbit Pelt.....	81
Advertising Your Rabbits	83
Using Rabbits in Science Fair Projects	85
Harvesting Angora Wool.....	87
Recycling Rabbit Manure	91
Making Worm Beds Out of Rabbit Manure	93



The History of Rabbits

Rabbits, Level 3, Activity 1

What Members Will Learn . . .

ABOUT THE PROJECT:

- A brief history of rabbits

ABOUT THEMSELVES:

- Their perception of their personal history

Materials Needed:

- Chalkboard or flip chart
- Pencils and paper

ACTIVITY TIME NEEDED: 35 MINUTES

ACTIVITY

Leader Notes

BRIEF HISTORY OF RABBITS

1. Rabbits have been mentioned in all recorded history.
2. Rabbits exist worldwide and on all continents.
3. Some believe that rabbits were first domesticated in Africa.
4. Some believe that during the Middle Ages, French monks domesticated rabbits by keeping them in protected areas and selectively breeding them.
5. Rabbits have survived, multiplied and continued to replenish the earth under the most adverse conditions.
6. Rabbits have been used for food in Asia for more than 3,000 years.
7. Rabbits have been marketed for food in European countries for more than 1,000 years.
8. In Spain, caves contain drawings of rabbits dating back to the Stone Age.
9. About 250 B.C., the Romans promoted rabbit production in all areas where they were in power.

Either you or a guest speaker can lecture about or discuss the history of rabbits.

Be sure all of the following information is included.

Outline on chalkboard or flip chart.

Check your local library for books, videos or slide sets that might cover rabbit history.

Leader Notes

10. In the 15th century, the Portuguese used rabbits as a supply of fresh meat for their long journeys.
11. In some areas, rabbits multiplied so rapidly that the Romans and Portuguese could not control them.
12. In Australia, rabbits imported from England multiplied so quickly because they had no natural enemies, that stringent methods of control were needed.
13. In Rome it was believed that eating rabbit meat made women beautiful.
14. During the second half of the 19th century, rabbits were taken to islands near the South Pole to provide fresh meat for whale hunters and research teams. In the sub-arctic temperatures during winter, when there was no vegetation of any kind, the rabbits adapted to living on seaweed which drifted ashore.
15. Ancient Aztecs held rabbit meat in high esteem.
16. Aztec court physicians prescribed rabbit meat as an effective body builder.
17. American Indians hunted rabbits since prehistoric times.
18. During the time of Confucius, the Chinese used rabbits in religious ceremonies. It is believed that 35,000 Himalayan rabbits per year were used as sacrificial animals.
19. By 1850, seventy million rabbits were produced annually in France.
20. Rabbits are raised in all 50 states.
21. Most felt hats are made of rabbit fur.

DIALOG FOR CRITICAL THINKING:

Q: Everything has a history. Some histories are longer than others, but even you at your age have a history. What are the highlights of your life? If you were writing a history for yourself, how would you like to be remembered and portrayed? Are there things in your history you are not proud of? What can you do to take care of this and change so that it does not affect your entire life?

GOING FURTHER:

1. Prepare a talk on the history of rabbits.
2. Write an essay on the history of rabbits for your local newspaper.



Recognizing the Rabbit's Skeleton

Rabbits, Level 3, Activity 2

What Members Will Learn . . .

ABOUT THE PROJECT:

- The principal bones of the rabbit skeleton

ABOUT THEMSELVES:

- Their personal beliefs about evolution and creation

Materials Needed:

- Bones from front leg
- Bones from hind leg

ACTIVITY TIME NEEDED: 30 MINUTES

ACTIVITY

Leader Notes

If you understand the skeleton of a rabbit, you will better understand the importance of genetics and conditioning for show rabbits.

Hand out the drawings of the “Rabbit Skeleton” activity sheet.

Parts of Rabbit Skeleton—Leader’s Key

Go over the various bones by pointing them out on the skeleton.

1. Cranial portion of the skull
2. Facial portion of skull
3. Hyoid
4. Mandible
5. Atlas
6. Epistropheus
7. Rib cage
8. 7th cervical vertebra
9. Scapula
10. Clavicle
11. Humerus
12. Radius
13. Ulna
14. 5th rib
15. 12th thoracic vertebra
16. 7th lumbar vertebra
17. Pelvis
18. Femur
19. Tibia
20. Tarsus
21. Phalanges (digits)

Have the members compare the front leg bones and the hind leg bones.

Give the members a few minutes to look over the skeleton and find all the bones.

Divide the group into teams and have a contest seeing which team can recognize the most bones. You could have a member from one team ask another team to locate a particular bone. Then reverse the procedure. Continue until all members have had a chance to ask questions.

DIALOG FOR CRITICAL THINKING:

Q: When looking at the bones of a rabbit, you will find that humans have similar bones, many with the same name. Some scientists believe humans evolved from animals. What is your opinion about the evolution theory?

GOING FURTHER:

1. Prepare a skeleton of a rabbit.
2. Prepare the bones of the front leg of a rabbit.
3. Prepare the bones of the hind leg of a rabbit.
4. Visit a natural history museum.

RECOGNIZING THE RABBIT SKELTON

Activity Sheet

The Rabbit Skeleton

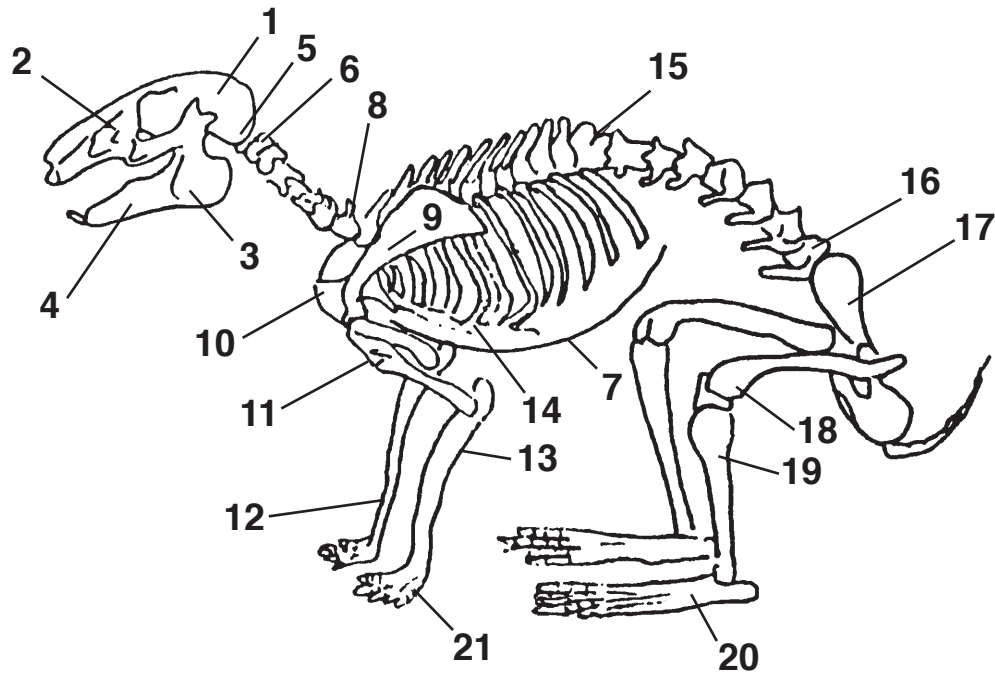

List the Bony Parts

- | | |
|-----|-----|
| 1. | 11. |
| 2. | 12. |
| 3. | 13. |
| 4. | 14. |
| 5. | 15. |
| 6. | 16. |
| 7. | 17. |
| 8. | 18. |
| 9. | 19. |
| 10. | 20. |
| | 21. |

Leader Notes



Raising Rabbits in Cold Weather

Rabbits, Level 3, Activity 3

What Members Will Learn . . .

ABOUT THE PROJECT:

- Different ways to make cold weather rabbit production successful

ABOUT THEMSELVES:

- The importance of maintaining a comfortable temperature for personal needs.

Materials Needed:

- Nest box
- Nest box heating pad
- Styrofoam
- Nesting materials (peanut hulls, wood shavings, cat litter, finely shredded paper, etc.)
- Chalkboard or flip chart

ACTIVITY TIME NEEDED: 25 MINUTES

ACTIVITY

Rabbit producers often experience increased kindling mortality and increased breeding problems during the winter months. This reduces rabbit numbers and profits.

Constant year-round production is important to the fancier and essential to the commercial breeder if they are to be successful on the show table or financially.

Whenever the expectant doe is exposed to temperatures of 45°F and below, you must use special management to protect the young kits. The more the temperature drops, the more important and more dramatic the management practices are.

How much protection a pregnant doe needs from weather conditions depends on the type of protection the doe's housing structure gives and how much additional heat is already provided.

It is very important that the core temperature within the nest be maintained at approximately 95°F at all times during the first 10 to 12 days.

Leader Notes

List main points on chalkboard or flip chart, or develop a question and answer session to involve the 4-H'ers.

Leader Notes

Use the right size of nest boxes. The closer the kits huddle in the nest, the more heat they conserve.

Nest boxes that are too large encourage does to sit in the box to protect themselves from the cold. If this happens, does often urinate and defecate in the nest box. Moisture in the nest box results in dead kits.

Place absorbant on the bottom of the nest box, such as wood shavings, peanut hulls, finely shredded paper, cat litter, etc. It absorbs moisture from the developing young.

The colder the temperature, the more absorbent the nesting materials must be.

Wooden nest boxes are best for cold weather kindling. Most of the heat loss from the kits is through the floor of the nest. To prevent loss through the floor, use several layers of newspaper in the bottom of the box or put in a layer of styrofoam. Put a board or wire bottom over the styrofoam or the doe will tear it up.

Some breeders attach styrofoam to the outside bottom of the nest box.

Heat lamps and heated nest box pads have been used by some breeders. The heat pads have proven more successful. If you use heat lamps direct the rays toward the bottom of the nest box from the underside of the cage.

Some disadvantages of heat pads and heat lamps are that many small rabbitries do not have electricity, it is difficult to control the temperature of the nest box, fire may break out, and rabbits tend to chew electrical cords.

Some breeders discontinue mating rabbits during cold weather. However, this is not recommended. Junior animals will not be available for the spring shows. Does not on a regular breeding schedule may become overly fat and difficult to breed.

A management practice known as “nest box rotation” can be used to perpetuate a breeding program throughout the entire year. Allow the doe to kindle in appropriately prepared nest box. Shortly after the doe has kindled, remove the entire nest box and take it to an area that is dry and warm (72°F).

This allows the core temperature of the nest to be maintained at around 95°F, warmed by the kits.

Return the nest to the doe’s cage at approximately 12-hour intervals to allow the doe to nurse the young. Leave the nest box in the doe’s cage for about 30 minutes and then return it to the warm dry area.

Ask if anyone can explain or describe “nest box rotation.”

Continue this practice for 10 to 12 days or until the outside temperature increases to the point that the kits will be warm enough.

This is somewhat time-consuming and you must be careful to return the proper nest box to the proper cage. This practice is used in many foreign countries all year. This method is successful because:

List advantages and disadvantages of “nest box rotation.”

1. The doe normally feeds the young only once or twice a day.
2. The doe can let her milk down at will and lactates rapidly.

Some breeders move the expectant doe into a warm area for kindling and return her to her cage after the kindling process. The manager then uses the nest box rotation method. By adapting one of several management practices available, one can successfully raise young rabbits all year.

DIALOG FOR CRITICAL THINKING:

Q: The temperature of your environment is important to you also. What happens when you are in school and it is too hot? How do you feel physically, mentally, and emotionally? What happens to you physically, mentally, and emotionally when you are too cold? Is there an ideal temperature for you at which you are at peak performance? Explain.

GOING FURTHER:

1. Visit a rabbitry during the winter.
2. Make a list of the costs and returns if these cold weather practices were used.

Leader Notes



Making a Wire Rabbit Cage

Rabbits, Level 3, Activity 4

What Members Will Learn . . .

ABOUT THE PROJECT:

- How to cut out and assemble a wire cage

ABOUT THEMSELVES:

- Their feelings about prisons and why we use them

Materials Needed:

- 14 Gauge 1" x 2" wire 30 inches wide for top
- 14 Gauge 1" x 2" wire 18 inches wide for sides
- 16 Gauge 1" x 1/2" wire 30 inches wide for bottom
- J clips
- J clip pliers
- Wire cutters
- Measuring tape
- Latches
- Chalkboard or flip chart

ACTIVITY TIME NEEDED: 40 MINUTES

ACTIVITY

Leader Notes

You need to know how to make cages for your rabbits in order to replace cages and make additional cages as the size of the herd increases.

First, decide what you want to use the cage for—is it to house a doe and her litter, a buck, or a growing rabbit? The breed you raise will also make a difference in the size of cage. Today we will build a cage for a commercial-type doe and litter.

A good size for this cage would be 30" x 48" x 18". Cut a piece of 1" x 1/2" wire 30" x 48" for the bottom.

Cut two pieces of 1" x 2" wire 18" x 48" for the front and back.

Cut two pieces of 1" x 2" wire 18" x 30" for the ends.

Using the J clip pliers, put the cage together.

Now you have a cage, but no door. To cut a door, start 6 inches from the left side and cut an opening 14" x 16" in the front. Leave 2 inches at the top and bottom of the opening.

List steps or pieces on chalkboard or flip chart.

Help each member or do the project in small groups.

Have the members help cut out the door.

Leader Notes

Here is a picture of what your cage should look like when finished.

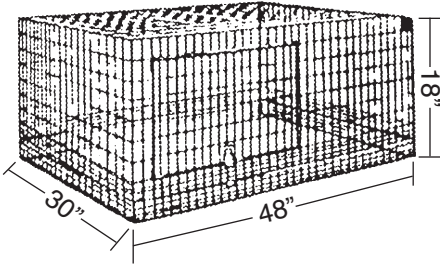

For the door, cut a piece of 1" x 2" wire 15" x 18". Using J clips, attach the door to the top of the opening in the front. Now attach the latches to the door.

If you are going to use a self-feeder, make an opening for it.

DIALOG FOR CRITICAL THINKING:

Q: While a cage for animals provides protection and well-being, a cage for people is seen as punishment. What experience have you had with prisons? If they are not a place you'd like to be, what things do you need to do to avoid prison? Are there ever good reasons to be in prison? Explain.

Q: Should criminals under 18 years old go to prison? Explain your answer. In cases where a young person has committed an extremely violent crime, should they be sentenced like an adult? Should they be sent to adult prisons? Explain.

GOING FURTHER:

1. Find out the size of cage you need for each rabbit breed.
2. Help the fair superintendent make rabbit cages for the fair.



Making a Rabbit Carrier

Rabbits, Level 3, Activity 5

What Members Will Learn . . .

ABOUT THE PROJECT:

- How to make a rabbit carrier

ABOUT THEMSELVES:

- Their feelings about the importance of using seatbelts

Materials Needed: (for 2 cages)

- 3' x 4', 1" x 2", 14 gauge welded wire
- 18" x 18", 1/2" x 1" welded wire
- 2 14" x 22" pieces of sheet metal
- 4 pieces scrap metal, 4" x 6"
- 4 20" pieces or rope, chain, or leather
- 48 J clips—24/cage (18 bottom, 6 sides)
- 8 1-inch sheet metal screws (attach cage to tray below floor line)
- 2 or 4 1/2-inch rings or wire to hinge top
- 16 1/8" x 1/4" nuts and bolts or small sheet metal screws to attach corners of sheet metal base

Tools Needed:

- Chalk for layout
- Wire cutters
- J clip pliers
- Sheet metal cutters
- Heavy pliers
- Hammer
- Drill and 1/8" bit
- Flat metal file
- Carpenter's square

ACTIVITY TIME NEEDED: 60–90 MINUTES

ACTIVITY

Leader Notes

Use this drawing and layout to help you build a rabbit carrier. This one will handle a medium-weight animal. Do not carry two rabbits in one cage unless they are separated by a partition. This plan has two separate cages (to save wire).

Demonstrate the steps as you go.

This cage is completely exposed, so take care where you place it. Do not leave the rabbit in the rain, cold wind, hot sun, or among dogs, as it has no way to protect itself and may die from the extra stress.

Note: Whenever you cut welded wire you lose the 1- or 2-inch ends that stick out. This shortens the length. File the rough edges smooth or adjust the pattern. For example, if the wire is too narrow to allow 12-inch sides, use 11 inches and drop the floor one inch.

Use one inch of shavings or litter in the base to absorb moisture.

Leader Notes

You may want to have the wire cut ahead of time, so it will take less time to demonstrate how to make the carrier.

INSTRUCTIONS:

1. Place wire flat on floor. Determine which way the long spaces run. Straighten all bends. Trim exposed wires.
2. Measure sides and tops. Chalk-mark where to cut or bend the wire. Do not cut the sides apart; continuous wire makes a stronger cage.
3. Cut the sides for one cage as one piece.
4. Cut cage A top either 8" x 18" or 9" x 16" for side or end attachment.
5. Bend cage A sides to form cage shape. Fasten with J clips.
6. Cut floor A size 16" x 8" of $\frac{1}{2}$ " x 1 wire. You may cut the floor $\frac{1}{2}$ " larger and use protruding wires to attach to walls instead of J clips.
7. Attach floor A to sides A up 3" from the base.
8. Bend top A at 8" or 16" with 1- or 2-inch overhang for closing and attach to side or end.
9. Lay metal flat. Use square to make pattern. Cut corner notches and bend sides. Use a metal shop brake if possible. Spot weld corners or drill and secure with sheet metal screws or bolts.
10. Fit cage inside base. Drill holes 1 inch above base for large sheet metal screws to secure cage to base by holding cross wires down. (You will later clean and empty cage by removing these screws.)
11. Handles are optional. Some omit for better packing; others prefer handles for ease of carrying. Cut two holes, 5 inches apart, in each small sheet metal plate. (Knot ropes or leather, or secure with wire.) Bend metal 90 degrees, 1 inch from bottom. Notch every 2 inches to slip between vertical cage wires. Center, 2 inches from top, and bend metal flat.
12. Attach snap fasteners to hold top shut.
13. Run hands carefully inside and outside cage. File or bend any roughness.
14. Check this cage for accuracy, then make the second cage even better.

DIALOG FOR CRITICAL THINKING:

Q: The carrier is meant to protect the animal much the same way infant car seats and seatbelts protect people. How often do you wear seatbelts? Discuss the importance of using seatbelts when you are in a car. What are your personal beliefs about seatbelts saving lives? Do you think wearing seatbelts should be a personal decision or mandated by law? Consider insurance costs in your discussion.

GOING FURTHER:

Make a wire hutch for your rabbits.

CONSTRUCTION OF A METAL RABBIT CARRYING CASE

Sheet Metal Base
(fold on dots— $\frac{1}{2}$ " notch)

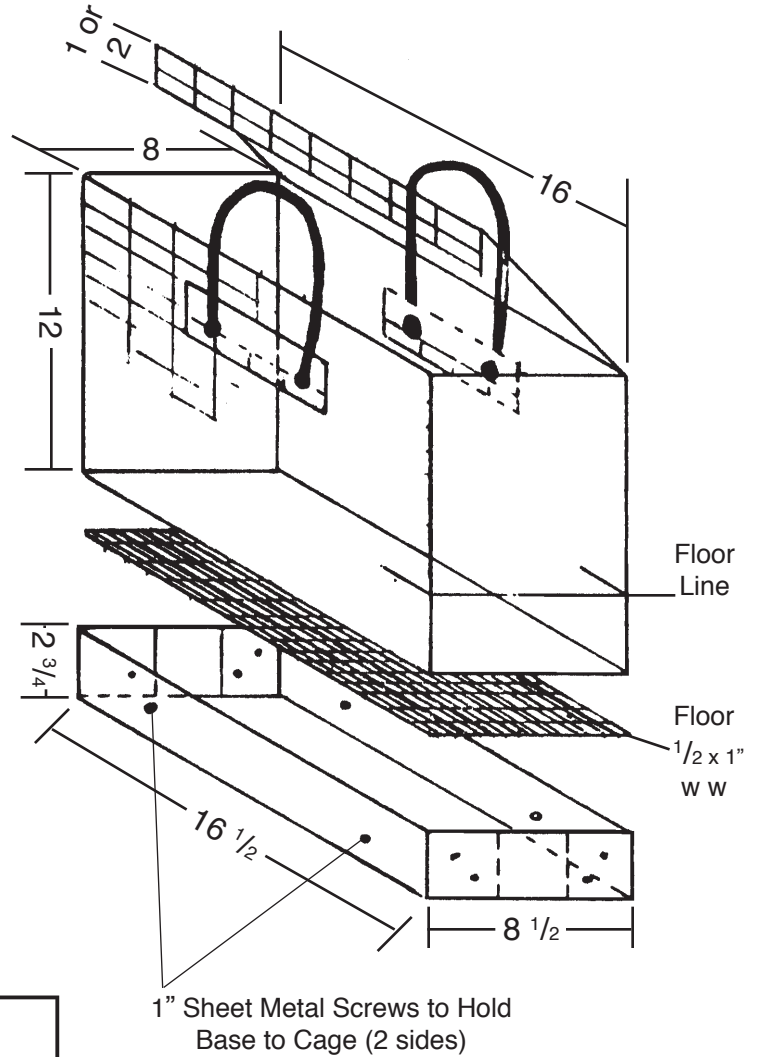
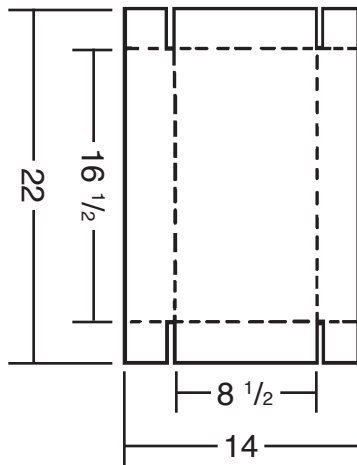

1 x 2" 14 Gauge Welded Wire Layout
for 2 Cages

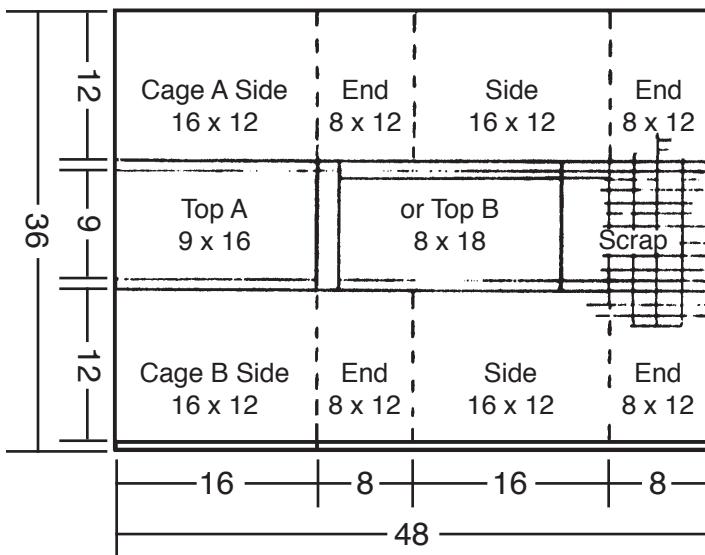

Leader Notes



Administering Rabbit Medicines

Rabbits, Level 3, Activity 6

What Members Will Learn . . .

ABOUT THE PROJECT:

- To administer medicines properly

ABOUT THEMSELVES:

- Their feelings about use of chemicals in society
- The value of drug programs

Materials Needed:

- Bottle of sterile water
- Oranges
- Syringes
- Medicated feed

ACTIVITY TIME NEEDED: 30 MINUTES

ACTIVITY

Leader Notes

You must know how to care for sick rabbits. Being able to administer medicines to your rabbits can save veterinary expenses.

There are three common ways to administer medicines to rabbits:

1. In the feed.
2. In the drinking water.
3. By injection.

Sulfaquinoxaline at the rate of 0.025 percent in feed is used to control liver coccidiosis. Griseofulvin at a rate of 0.37 g/lb of feed is used to control fungal infections. Long-term usage is not recommended.

Piperazine citrate, 100mg/100ml water, is a one-day treatment to eliminate roundworms.

Penicillin G injections are used for vent disease, pneumonia, etc. Penicillin injections should be given intramuscularly. Check the actual dosage with your veterinarian.

Demonstrate how to fill the syringe. Now demonstrate how to inject the rabbit using an orange as the patient.

Leader Notes

Have the 4-H'ers try to inject an orange.
Remind them:

1. That some medicines must be injected just under the skin while others must be given intramuscularly. Check the medicine bottle to find the method to use.
2. That they should check with a veterinarian on the dosage to be used.
3. That all medicines should be withdrawn for a period of time before slaughtering. Check the medicine bottle or feed label for the length of time.

To learn how to give an intramuscular injection, use an orange for the patient. Put two or three cubic centimeters of water in the syringe and inject the orange. Stick in the needle and push in the syringe's plunger.

Sometimes the veterinarian will prescribe powdered drug, capsules, or liquid medication. To administer these, grasp the rabbit by the loose skin behind its neck and tip it back, sliding your other hand under its haunches at the same time. Allow the animal to lean against you as if you were checking the sex. Tip the rabbit's nose up, gently press the jaws apart with the thumb and forefinger. Place the medicine well back on the rabbit's tongue. Allow the rabbit to close its mouth and gently stroke the chin until the rabbit swallows. Liquid medication can be given this way using an eye dropper to put the medicine on the rabbit's tongue.

DIALOG FOR CRITICAL THINKING:

Q: The drugs you use to prevent sickness in your animals are all made from chemicals. Chemicals in general have a bad reputation. Discuss the issue of chemicals in everyday life, both the benefits and the disadvantages. What can we do to cut down on chemical pollution?

Q: Most schools run programs to educate and encourage students to avoid drugs/chemicals. What makes these programs good or bad? How effective are they? If you were designing a program, how would you set one up?

GOING FURTHER:

1. Research common rabbit diseases.
2. Investigate how to control all kinds of parasites.



Controlling External Parasites

Rabbits, Level 3, Activity 7

What Members Will Learn . . .

ABOUT THE PROJECT:

- About common external parasites
- How to control these parasites

ABOUT THEMSELVES:

- To develop a sense of their own personal hygiene

Materials Needed:

- Chalkboard or flip chart

ACTIVITY TIME NEEDED: 20 MINUTES

ACTIVITY

Leader Notes

An understanding of potential parasite problems and how to control them is essential for a successful rabbit raising project.

EXTERNAL PARASITES OF RABBITS

Ear Canker or Ear Mange—Ear canker is caused by the common ear mite (*Psoroptes cuniculi*). The mites live in the ear canal and damage the skin. A brown, waxy material soon covers the inner ear. This encrustation consists of dried blood, cellular debris, keratin, and mites in various stages of development.

An effective treatment is to remove the encrustation with a cotton swab soaked in mineral or vegetable oil. Allow some of the oil to run into the ear passage. Repeat this procedure in four days. A 0.25 percent suspension of Lindane in mineral oil is an effective medication. Ivermectin has proven to be a very effective at controlling ear canker. Inject 0.20 cc of Ivermectin just beneath the skin at the nape of the neck. Remember all your rabbits must be treated if you find an infected animal. Sanitation is important for control.

Mange—Mange is caused by *Psoroptes cuniculi*, *Notoedres cati*, and *Cheyletiella parasitovorax*. These mites cause the skin to become dry, scaly, irritated, and itchy with hair loss in the affected areas. Treat with a powder containing 0.25 percent Lindane. The best control method is good sanitation.

Fleas—The rabbit flea, *Spilosyllus cuniculi*, and dog and cat fleas, *Ctenocephalides canis* and *Ctenocephalides felis*, occasionally have been

List cause, symptoms and treatment for each parasite on chalkboard or flip chart.

Describe symptoms or show a rabbit with symptoms and see if members can discuss treatments.

Leader Notes

reported on rabbits. There are four stages in the life cycle of a flea—egg, larva, pupa, and adult. The eggs are deposited in nesting materials and cracks of the nest boxes. The eggs hatch into larvae which then form the pupae from which the adult emerges. Treat the rabbits by dusting with a commercial preparation of Pyrethrin or Rotenone. Destroy nesting materials and wash the nest boxes using bleach. Keep cats and dogs away from all rabbit supplies, especially nesting materials.

DIALOG FOR CRITICAL THINKING:

Q: Taking care of your own health and physical well-being is as important as taking care of your rabbit's health needs. What are some things you do daily to tend to these needs? How important are they? How do you and your friends perceive those students who do not take good care of themselves?

Q: Has your school ever experienced an outbreak of lice or other external parasites? What measures were taken to control and/or eliminate the problem?

GOING FURTHER:

Visit a veterinarian to see if he or she has animals or visuals to show examples of external parasites.



Controlling Internal Parasites

Rabbits, Level 3, Activity 8

What Members Will Learn . . .

ABOUT THE PROJECT:

- The common internal parasites
- How to control these parasites

ABOUT THEMSELVES:

- The importance of personal sanitation
- Possible human parasites
- Their feelings about social parasites

Materials Needed:

- Chalkboard or flip chart

ACTIVITY TIME NEEDED: 30 MINUTES

ACTIVITY

Leader Notes

INTERNAL PARASITES OF RABBITS

You must learn about the common internal parasites in order to be able to control them in your rabbits.

List each parasite on chalkboard or flip chart as it is discussed. Also, list symptoms and controls.

COCCIDIA—Coccidiosis is the most common parasite disease in domestic rabbits. The microscopic parasites invade the liver and small intestines. There the parasites multiply and are passed out of the body in the feces (oocysts).

Four species of *coccidia* live in the small intestines and one species infects the liver. Infections of the liver after (or more than) 16 days can be recognized by white, circular nodules on the liver.

Discuss *Coccidia* life cycle.

Control involves the minimization of fecal contamination of feed and water. Feed or drinking water containing 0.025 percent sulfaquinoxaline is an effective treatment for liver *coccidia*. Intestinal *coccidia* develop a tolerance to the drug, so it should not be fed continuously.

STOMACH WORMS—*Obelisoides cuniculi* are slender, cylindrical, reddish roundworms about one-half inch long. In the life cycle, eggs are passed in the feces; after a short time the eggs hatch into infective larvae. The larvae are ingested and pass to the stomach where they grow to adults. Diarrhea and emaciation may result. Stomach worms are rarely found when the rabbits are raised in hutches off the ground. The best control is good management practices.

INTESTINAL WORMS—*Trichostrongylus calcaratus* live in the small intestines. They are about the same size as stomach worms and have a similar life cycle. Infection is rare when rabbits are raised in hutches above the ground. Good sanitation and management practices are the best control.

PINWORMS—*Passalurus ambiguus* is a common parasite of rabbits. These are one-half inch long, glistening, white worms. They are often seen on the surface of the freshly passed feces. These parasites are spread by contaminated feed and water. A one-time treatment with Piperazine citrate (100 mg/100 ml water) is effective. Sanitation is the best control.

TAPEWORMS—Tapeworms occur in rabbits as adults in the intestines and as larval forms in the liver and abdominal cavity. Adult forms are very rare in hutch-raised rabbits, but larval forms are observed.

The rabbit tapeworm, *Cittotenia ctenoides*, is flat, ribbon-shaped, and segmented. The head has four suckers with which the worm attaches to the lining of the intestine. When many tapeworms are present, diarrhea and emaciation occur. Control is accomplished by good sanitation.

Discuss tapeworm life cycle.

The larval forms of tapeworm most often found are those of *Taenia pisiformis*, dog and cat tapeworm. These are acquired when the rabbit ingests feed or water contaminated with the feces of dogs or cats. The eggs hatch and the larvae penetrated the intestine and migrate to the liver. They migrate in the liver leaving a white streak. Later they leave the liver and enter the abdominal cavity. They may form small fluid-filled cysts. Each cyst contains an embryonic tapeworm which when consumed by cats or dogs, will develop into a mature tapeworm.

Exclude dogs and cats from all areas where rabbit supplies or rabbits are kept. Do not give dogs and cats raw rabbit carcasses. Management is the best control.

DIALOG FOR CRITICAL THINKING:

Q: Sanitation is as important for you as it is for rabbits. Discuss common sanitation practices everyone should follow. What does your peer group think of people who do not practice these sanitary procedures? Discuss the results of poor sanitary procedures and personal hygiene as it affects you.

Q: What are some human parasites that you know about? List and discuss.

Q: People who use other people for personal gain could be referred to as a type of parasite. They live off of and use people for various reasons i.e., copy others' homework, bum rides but never offer rides to others, hang around a person because he or she is popular. How do you feel about these people? Think of ways to help them change.

GOING FURTHER:

Visit a veterinarian and see samples of these parasites.

CONTROLLING INTERNAL PARASITES

Activity Sheet

Life cycles of Coccidia and Tapeworm

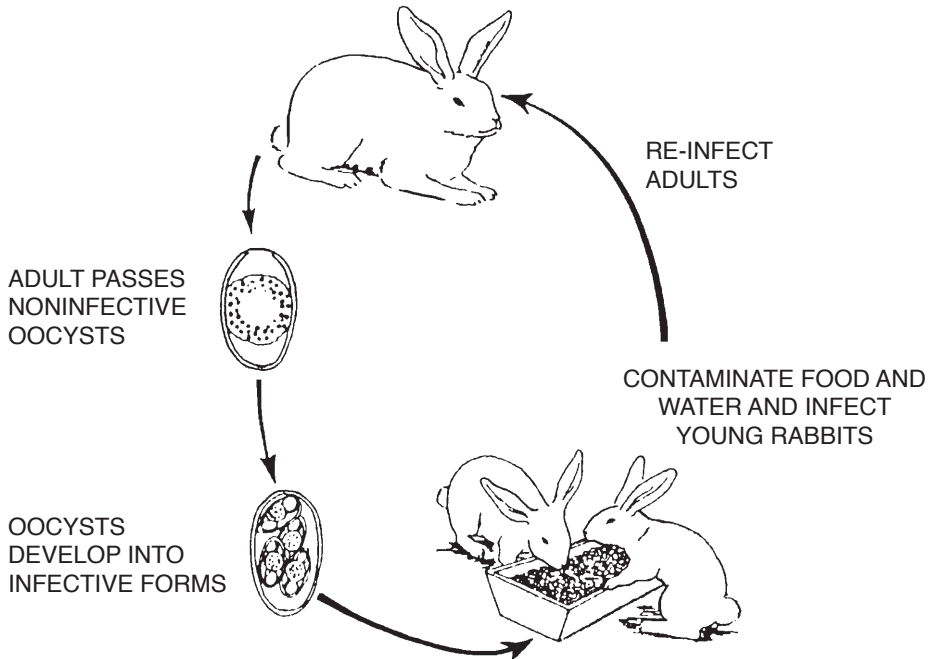

Life cycle of *coccidia*.

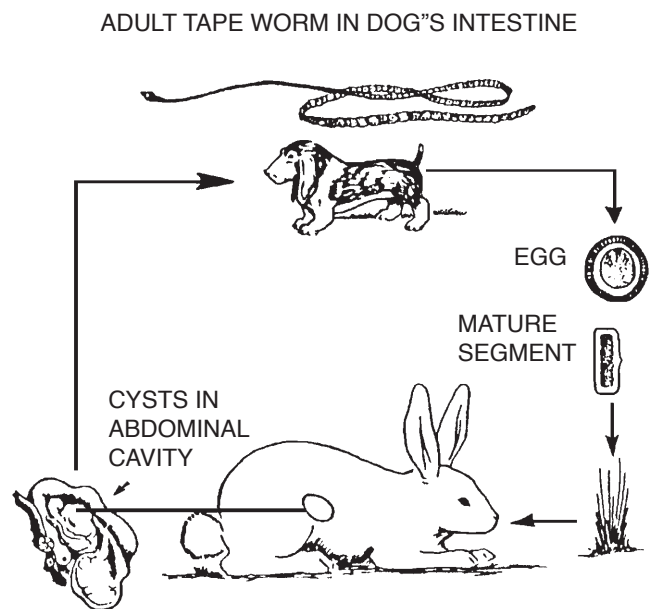

Life cycle of the dog tapeworm



Common Diseases of Rabbits

Rabbits, Level 3, Activity 9

What Members Will Learn . . .

ABOUT THE PROJECT:

- The common diseases of rabbits, the causes and methods of prevention

ABOUT THEMSELVES:

- The benefits of preventative health care

Materials Needed:

- Chalkboard or flip chart
- Paper
- Pencils
- Rabbit Diseases and Health Problems (video)—optional

ACTIVITY TIME NEEDED: 60 MINUTES

ACTIVITY

Leader Notes

You must be able to recognize when your rabbit is ill so you can treat it when needed.

Discuss the common rabbit diseases.

DISCUSS THE FOLLOWING COMMON RABBIT DISEASES:

Have each member make three columns on their paper. Label the columns:

I. **Coccidiosis**

1. Symptoms
2. Cause
3. Control

A. **Symptoms** — Common and serious problem especially in young rabbits. Symptoms vary with severity of exposure but include loss of appetite, diarrhea, tough coat, and loss of weight. Depending upon the type of *coccidia* present the disease may involve the liver (liver form) or the intestines (intestinal form).

Have members record information in each column for each disease as it is discussed or viewed.

Post-mortem examination reveals small white spots on liver when liver form is present. In severe infections the liver may be enlarged. With the intestinal form no visible lesions may be observed, although careful examination may reveal small hemorrhages on inner surface of intestines.

Pictures of rabbits with each disease, if available from library or veterinarian, would be helpful.

B. **Cause** — five different species of protozoan parasites or one-celled animals, which injure the lining of the bile ducts of the liver, intestines, or cecum depending on the particular species present, causes the disease.

C. **Control** — Sulfa added to the drinking water at a rate of 1¹/₂

ounces per gallon. Treat for 14 days. If necessary, repeat after 7 days on plain water. To be fully effective, accompany treatment with strict sanitary practices. Clean and disinfect hutches twice weekly with disinfectant. Remove manure daily and do not allow droppings to come in contact with feed and water. Clean and disinfect feeder regularly. Separate young from other rabbits as soon as possible. Where disease is a persistent problem, special feeds can be used for prevention.

II. **Mycoïd Enteritis** (“*Bloat*” or “*Scours*”)

- A. **Symptoms** — Symptoms include loss of appetite, depression, rough coat, gritting teeth, bloated abdomen, and diarrhea, often containing gelatinous material. Post-mortem examination may reveal excess mucus or fluid in the intestines. Fluid often present in stomach. The condition can often be demonstrated in live animals by shaking it close to the ear. If it sounds as if it is full of fluid, mucoid enteritis is present.
- B. **Cause** — Specific cause still unknown. Not believed to be contagious or of nutritional origin, but may be due primarily to constipation.
- C. **Control** — Strict sanitation of hutches and feeding and watering equipment important for control. Be sure the rabbit has access to a constant supply of water. (If automatic watering nipples are used, be sure the rabbits know how to use them.)

III. **Salmonellosis** (“*Scours*”)

- A. **Symptoms** — Disease may be acute or chronic. Characterized by diarrhea, loss of appetite, loss of weight, nasal discharge, rapid breathing, and fever.
- B. **Cause** — Post-mortem examination reveals few to numerous small white spots on liver, spleen, kidneys, or pancreas. Pneumonia may be present. Ulcers are sometimes found along the intestines. Petechial hemorrhages (pin-point, measles-like, red spots) are occasionally seen on the intestinal wall.
- C. **Control** — Several members of the *Salmonella paratyphoid* group of bacteria affect rabbits. Usually *S. typhimurium*, *S. enteritidis*, or *S. aertryche*. Some feeds can be used as a preventive when the problem is troublesome. For specific recommendations see your local veterinarian.

IV. Entero Toxemia

- A. **Symptoms** — Diarrhea usually only symptom. May go off feed and is found dead in 24 hours. Usually seen in 4–8-week-old rabbits.
- B. **Cause** — *Clostridium spiroformes*, a bacteria, is the specific cause. It produces a toxin which kills the rabbit. The disease is brought on by overfeeding with a high carbohydrate feed (contains a lot of grain).
- C. **Control** — Change to a higher fiber (low energy) diet and reduce the amount of feed. The addition of hay or straw to the ration is also helpful. Antibiotics may be helpful.

V. Pasteurellosis (“Snuffles”)

- A. **Symptoms** — May be acute or chronic. Symptoms include nasal discharge, sneezing, coughing, watery eyes, head shaking, and loss of weight. Rubs nose with front feet. Post-mortem examination reveals a reddening of the windpipe, hemorrhages, and solidified red patches in the lungs; membranes of the nose and sinuses may be inflamed.
- B. **Cause** — Bacterial organism known as *Pasteurella mulocida*. (*Brucella*, *streptococcus*, *bordatella*, and other bacteria may occasionally produce a similar condition.) Infection of the reproductive tract by *Pasteurella* organisms occurs and may result in sterility.
- C. **Control** — Antibiotics are not effective. Strict sanitary practices should be applied to hutches. Culling of affected rabbits is the most effective method of control to date. Selection of resistant breeding stock may be helpful.

VI. Listeriosis

- A. **Symptoms** — Young most frequently affected. Animals become emaciated. May show nervous disturbance — twist head to one side.
- B. **Cause** — Bacterial organism, *Listeria*, is the cause.
- C. **Control** — Affected animals should be destroyed and disposed of properly.

VII. Mastitis

- A. **Symptoms** — “Blue Breasts” mammary glands become hot, reddened, and swollen — later may appear blue in color. May go off feed and run temperature. Condition may spread through rabbitry.
- B. **Cause** — Usually *Staphylococcus* or *Pasteurella* infections, but various other bacteria may be responsible.
- C. **Control** — Strict sanitary program and thorough disinfection of contaminated hutches.
For specific recommendations see your local veterinarian.

VIII. Caked Breasts

- A. **Symptoms** — “Caked udder,” one or more of mammary glands swollen, and hot and firm.
- B. **Cause** — Milk not drawn from glands as rapidly as formed. Too few young or young not nursing sufficiently.
- C. **Control** — Correcting faulty management most important. Reduce ration one-half on the day doe kindles and gradually increase to full feed in 7 days. Relieve congested glands by partial milking. Rub lanolin into affected glands to soften. Do not wean young from heavy milk doe abruptly.

IX. Ear Canker

- A. **Symptoms** — “Ear mange” — Rabbit shakes head and flops ears. Scaly crusts starting at base of inner ear.
- B. **Cause** — Infestation of skin with mites.
- C. **Control** — Remove the crust and scabs with a Q-tip. Then apply mineral oil, containing a miticide, to the affected ears with an eye dropper. Use the 3 x 3 x 3 method. Treat every day for 3 days, every other day for three treatments, and once a week for three treatments.

X. Ringworm

- A. **Symptoms** — Loss of hair usually in circumscribed patches, often starts on head but may involve any part of body. Not accompanied by scratching as a rule. Infection may spread to humans; wear gloves when handling affected animals.

- B. **Cause** — Fungus infection of the skin. The fungus can be transmitted from man to rabbit or vice versa. Cats and other animals can also carry the fungus and transmit it to rabbits.
- C. **Control** — Clip $\frac{1}{2}$ -inch area around lesion and treat with good fungicide such as strong tincture of iodine or mixture of 2 ounces tincture of iodine, 2 ounces tincture benzoine, and $\frac{1}{2}$ -ounce salicylic acid mixed with alcohol to make a total of 6 ounces. Culling the affected rabbit is sometimes the best method of control.

XI. Sore hocks

- A. **Symptoms** — Bruised areas on or under surface of hocks. Often become infected or abscessed. Front feet may become affected.
Prevention by good management is best means of handling this problem — clean, dry floors or wire that provides good supporting area without compromising sanitation.
Dispose of “stampers” and protect the others from exciting influences.
- B. **Cause** — Irritation from wire floors, stamping, or irritation from urine often starts condition. Nervous and heavy animals are more often affected.
- C. **Control** — Regular inspection for tenderness of feet or early lesions. At first sign, place affected animals on ground or place a piece of plywood or drywall into hutch. This often clears up early cases.
Clip and clean affected areas with disinfectant. Treat locally with wide-spectrum antibiotic ointment. Penicillin injections are helpful in some cases. If lesions are abscessed, surgical drainage may be necessary.

DIALOG FOR CRITICAL THINKING:

Q: Prevention is the key to health. Think of all the things you do that contribute to your health in a preventive manner: simple hygiene, medical practices, avoidance of substances like cigarettes and drugs/ alcohol, and anything else that prevents health problems.

GOING FURTHER:

Invite veterinarian to meeting to discuss disease problems in your area.

Leader Notes



The Rabbit's Digestive System

Rabbits, Level 3, Activity 10

What Members Will Learn . . .

ABOUT THE PROJECT:

- The parts of the digestive system
- The functions of the digestive system

ABOUT THEMSELVES:

- The functions of various parts of their digestive system
- Their feelings about using rabbits for human research

Materials Needed:

- Diagrams of a rabbit's digestive system for each member
- Preserved digestive system of a rabbit (optional)

ACTIVITY TIME NEEDED: 30 MINUTES

ACTIVITY

Leader Notes

It is important to know the function of each part of the digestive system in order to understand rabbit nutrition.

Hand out diagrams of the rabbit's digestive system.

The rabbit can digest roughage because of its digestive system. The digestive system consists of the mouth, esophagus, stomach, small intestines, cecum, large intestine, rectum, and anus. The esophagus functions as a tube for the passage of food from the mouth to the stomach. The simple stomach is where digestion for the food begins. In the small intestines, digestion continues. It is in the small intestines where many of the nutrients from food are absorbed. The cecum is a holding area where bacteria digest portions of the feed not digested in the stomach or small intestines. The cecum allows rabbits to digest roughage. The large intestines absorb water and minerals. The fecal pellets are formed in the large intestines and stored in the rectum.

Fecal pellets are not always formed. Usually during the night hours, soft stools are passed. These soft stools are caught and eaten by the rabbit. Stool eating, coprophagy, is an essential part of rabbit nutrition. Essential elements of the diet are absorbed from the soft stool. Rabbits kept in all-wire cages still practice coprophagy. They get the soft stools directly from the anus.

Now have the 4-H'ers identify the parts of the preserved digestive system.

Leader Notes

DIALOG FOR CRITICAL THINKING:

Q: Compare the rabbit's digestive system to your digestive system. What is similar? What is different? Contrast the size of digestive tract parts. Discuss the ethics of using rabbits for research instead of humans. How do you feel about sacrificing rabbits and other animals for human research?

GOING FURTHER:

1. Preserve a rabbit's digestive system.
2. Invite a medical researcher to discuss how rabbits are used.

THE RABBIT'S DIGESTIVE SYSTEM

Activity Sheet

Rabbit Digestive System

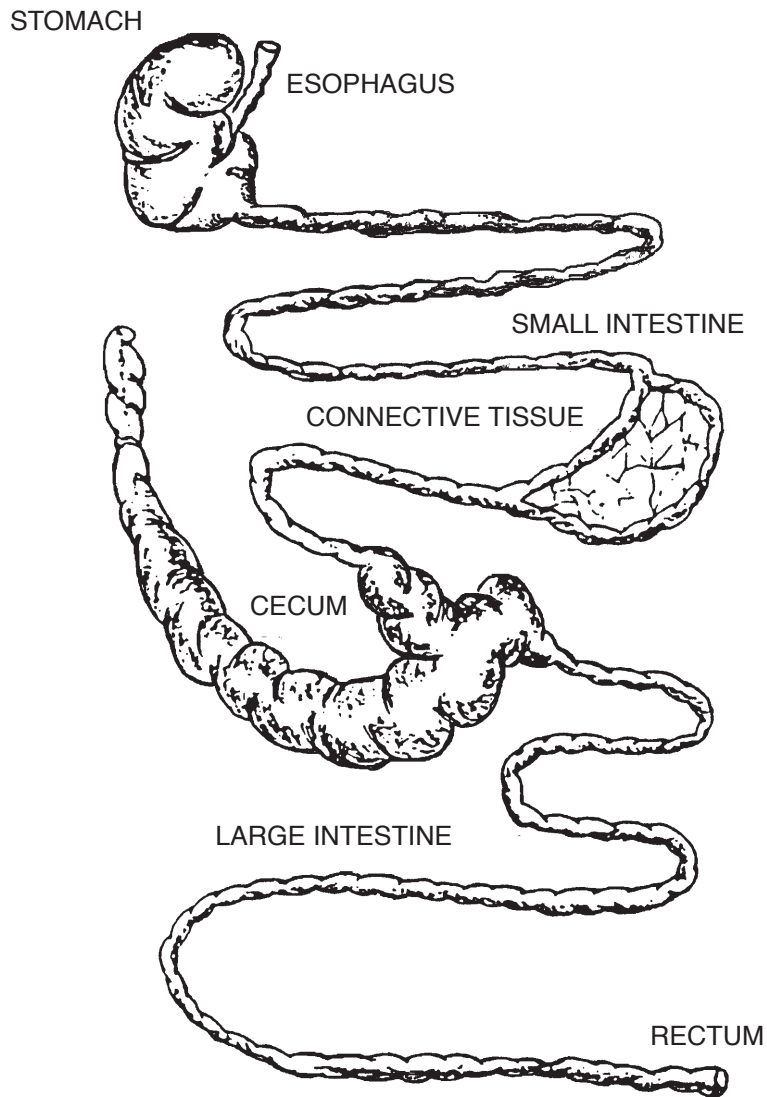

Leader Notes



Understanding a Rabbit's Estrus Cycle

Rabbits, Level 3, Activity 11

What Members Will Learn . . .

ABOUT THE PROJECT:

- To understand rabbit ovulation
- To understand maturation time and why some does don't conceive

ABOUT THEMSELVES:

- To evaluate their feelings about puberty
- To develop an understanding of puberty and the changes it brings

Materials Needed:

- Several does

ACTIVITY TIME NEEDED: 30 MINUTES

ACTIVITY

Leader Notes

Rabbits will breed more or less at any time of year. Rabbits do not have an estrus cycle in the strict sense of the word.

The female rabbit ovulates only after coitus (copulation, mating). The usual interval between stimulation (mating) and ovulation is 10 hours. Within one hour of mating, sufficient follicle-stimulating hormone is produced by the pituitary to cause the ripening of the follicles.

Females can remain in heat for a month or more in the absence of mating.

Age of puberty in rabbits varies among the breeds, with smaller breeds maturing earlier. Does born in the fall reach fertility (puberty) in about 5 ½ months, but those born in the spring require 8 ½ months. Does tend to copulate one to two months before first ovulation.

Some does are believed to pass into an anestrous (nonfertile) condition during late summer. However, many people raise young rabbits throughout the entire year. Fall litters often are smaller than those born at other times of the year, which would suggest that fertility in rabbits is lower in late summer.

The doe ovulates immediately following a pregnancy. This is why you can immediately breed a healthy doe that loses her litter.

Discuss the differences in estrus cycles between a rabbit and another familiar animal.

Leader Notes

Have the members examine the does present and decide if they are likely to conceive if mated today.

The vulva of the doe in heat is usually purple to reddish pink and somewhat swollen. This is a good indication that the doe will conceive if mated at this time. Usually the vulva is a pale pink.

DIALOG FOR CRITICAL THINKING:

Q: About what age does puberty begin in young people? What changes occur in your body during puberty? Does everyone mature at the same time and rate? What kinds of feelings do you experience during this time?

GOING FURTHER:

1. Visit a rabbitry that uses artificial insemination.



Determining Pregnancy in Rabbits

Rabbits, Level 3, Activity 12

What Members Will Learn . . .

ABOUT THE PROJECT:

- How to palpate a doe

ABOUT THEMSELVES:

- To evaluate personal feelings about human pregnancy and the risks involved

Materials Needed:

- Does who were bred about 14 days ago
- Carpet
- Chalkboard or flip chart

ACTIVITY TIME NEEDED: 30 MINUTES

ACTIVITY

Leader Notes

Learning to palpate a doe has many advantages. Some reasons to palpate are:

1. Proper feeding practices for bred and nonpregnant does, thus preventing nonpregnant does from becoming obese.
2. Nonpregnant does can be rebred earlier.
3. Early elimination of does who have breeding problems.

PALPATION (Determining Pregnancy)

Palpation is a skill that allows you to keep the herd in production. Does that aren't bred can be rebred at a much earlier time than by waiting for the gestation period to be completed. Conception does not take place with all matings in rabbits. This is common in all species of animals. However, a rabbit breeder should have about 70 percent conception on the first mating. If your conception rate falls below 70 percent, examine your breeding program for management problems or a pathological cause of the decrease in conception.

Palpation can be frustrating to beginners as they often do not understand the anatomy of the female reproductive system. The reproductive tract in rabbits consists of the vagina, body of the uterus, cervix, horns of the uterus, oviducts, and ovaries. The ovaries are attached to the dorsal portion (back of the abdominal cavity) in masses of ovarian fat. This attachment is just behind the kidneys on each side of the body. The ovaries are about the size of small beans.

Ask the 4-H'ers how they determine if their does are pregnant. Allow everyone a chance to participate in the discussion.

Outline on chalkboard or flip chart or show diagram of rabbit female reproductive tract (Handout 1).

Leader Notes

The function of the ovary is to produce the eggs (ova) that are capable of being fertilized by the male sperm. The ovaries are connected to the horns of the uterus via small tubes, the oviducts. The function of the oviducts is to transport the eggs to the uterine horns.

The uterus is Y-shaped and is attached on the anterior end of the oviducts. The length of the uterine horns are determined by heredity and they control the size of the litter. The uterine horns and body of the uterus are where the sperm and egg unite and where the fetuses will develop to maturity.

The cervix divides the uterus from the vagina and provides a barrier of secretions that prevent organisms from entering the uterus and disrupting the pregnancy. The vagina extends from the cervix to the vulva and is the area that receives the sperm.

Demonstrate this technique.

Outline steps on chalkboard or flip chart.

PALPATION TECHNIQUE

1. *Position:* You and the doe should be relaxed and comfortable. Rest the posterior abdominal area of the doe in the palm of your hand.

2. *Palpation Site:* The area to be explored is behind the last rib and in front of the pelvis. Early in the gestation period (9-13 days) the fetuses will be mostly in the high rear part of the abdominal cavity. Later they will be lower and more forward in the abdominal cavity.

3. *Restraint:* Gently lift the hand and touch the posterior abdominal muscles just in front of the hind legs and pelvis. The thumb should be on one side of the abdominal cavity and the four fingers on the opposite side. The doe should be in a stretched out position. Raise her rear quarters until just the tips of her rear feet are touching the table. Wait for the doe to relax in this position. Use your other hand to restrain the doe by holding her head gently.

4. *Hand Movement:* When the abdominal muscles are relaxed, feel for the internal structure between the thumb and fingers (hold fingers tightly together) starting at the most posterior area of the abdominal cavity. Never use more pressure than it would take to squash a grape. Move your hand to explore the entire abdominal cavity. Feel for a very round, firm, marble-shaped object in the early stages of pregnancy. After 15 days the fetus will start to elongate. Stop once you locate a fetus.

Have members palpate a doe.

For beginners, it is easiest to palpate the does at about 14 days into the gestation period. The marble-sized fetuses are easiest to feel and are difficult to damage at this time. Beginners may find it helpful to withhold feed for 24 hours before palpation.

DIALOG FOR CRITICAL THINKING:

Q: Amniocentesis is a procedure used on humans that not only determines pregnancy, but also the sex and any deformities a fetus may have. Discuss the advantages and disadvantages of being able to do procedures like this.

Q: If you were told by the results of an amniocentesis that you had a very sick child, what do you think you would do? What are the advantages of knowing this early in a pregnancy? Would you even want to know all the information an amniocentesis could give you?

FEMALE REPRODUCTIVE TRACT

Activity Sheet

Female Reproductive Tract

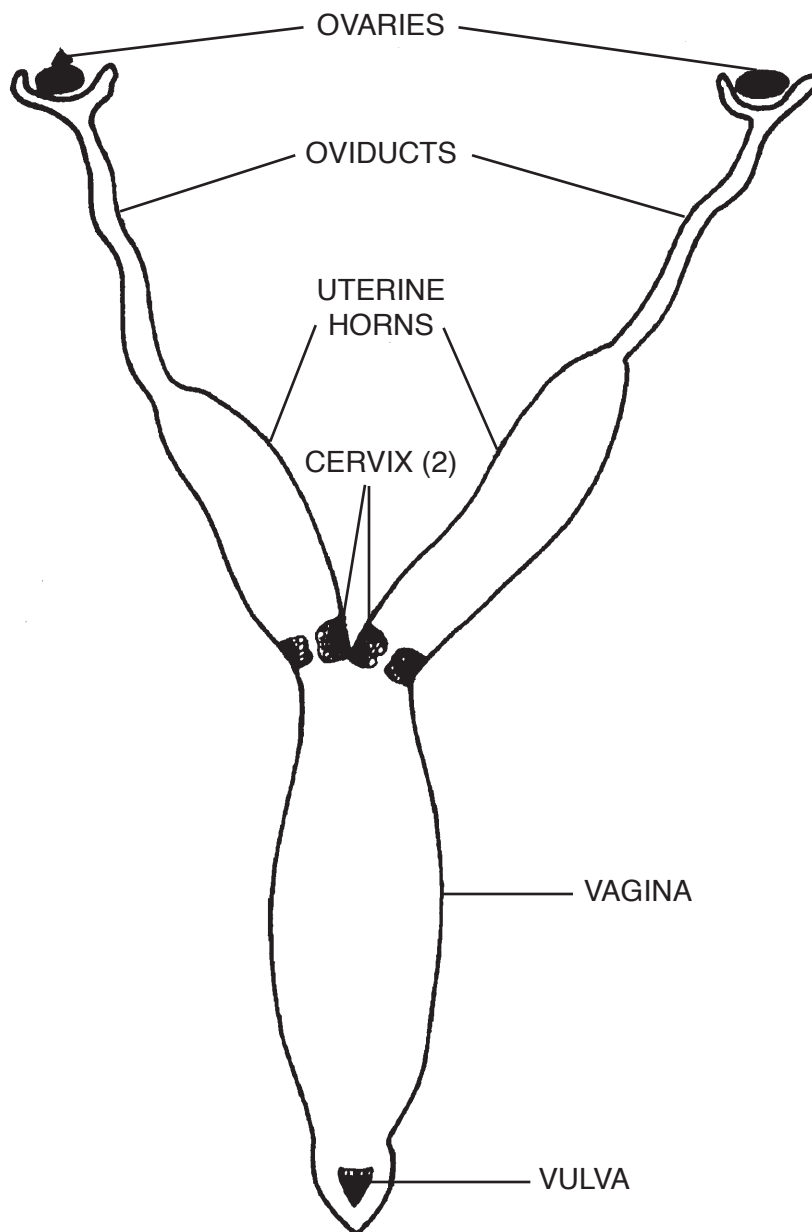



Raising an Orphaned Rabbit

Rabbits, Level 3, Activity 13

What Members Will Learn . . .

ABOUT THE PROJECT:

- How to foster kits to another doe
- How to feed and care for orphaned animals

ABOUT THEMSELVES:

- Their feelings about foster care for children

Materials Needed:

- Kit or small rabbit
- 1 pint 2% milk
- 2 egg yolks
- 2 Tablespoons powdered milk
- 2 Tablespoons corn syrup
- 1 teaspoon bone meal
- A large bowl
- Spoon
- Chalkboard or flip chart

ACTIVITY TIME NEEDED: 30 MINUTES

ACTIVITY

Leader Notes

On occasion a doe will die during the kindling process due to unforeseen and unpreventable complications, or a doe will have a litter so large that she can't care for all of the young. If a foster doe cannot be located, you must care for the orphaned rabbits.

Fostering can be a very successful and rewarding experience. Follow these general guidelines to make this practice successful.

1. Keep a record of each kit fostered. This can be accomplished by placing small tattoo marks in one or both ears. For distinctly marked animals, a photograph of the side profile of each kit will help identify it.
2. Foster the young to litters that are within 72 to 96 hours of the same age.
3. The kits should be about the same physical size.

Ask members to help you list things to consider when fostering kits to another doe before you list these guidelines. Compare youth list with this list.

Leader Notes

4. Don't overload the foster doe, so the original litter isn't deprived of milk. Small breeds should not be expected to care for more than six kits. The commercial type breeds should not be expected to care for more than eight kits.
5. Before transferring the kits, wash your hands thoroughly in plain water. Do not use soaps, hand creams, etc.
6. Examine each of the original kits. Then examine the kits to be fostered before placing them in the nest.
7. Check the nest box every 12 to 24 hours after the fostering process for the next 5 to 7 days to see if the young are being properly cared for and fed.

Unfortunately, there is not always a foster mother available when needed. Then you must decide whether to hand feed the kits or humanely kill them.

Discuss the time and patience required to rear orphaned kits. List steps and discuss thoroughly. Emphasize the importance of the decision to attempt to feed the orphans as opposed to humanely destroying them.

Feeding orphaned kits is not difficult and results can be very gratifying. However, it requires a lot of time and patience.

To be successful, you must do the following:

1. Provide the young kits with a warm, dry nest. The nest temperature must be kept at 90° to 98°F.
2. Confine them to a small area. Put them in a small bowl or pan lined with soft nesting material, fur, or a soft towel.
3. Heat the artificial nest for 10 to 15 days.
4. Hold each kit in an upright position and gently stroke the area between the hind legs several times with a cotton ball or other soft material until the kit eliminates.
5. When natural eliminations are noticed in the nest, you can stop the manual stimulation.
6. Feed the kits with a small nipples bottle or an eye dropper.
7. Feed the kits two times per day at 12-hour intervals.
8. Be careful the kits do not inhale any fluid into the respiratory tract and that they are not overfed. One to three eye droppers of formula per feeding are probably sufficient depending on age and size.
9. At about 14 days old, offer the kits bread that has been soaked in milk, two or three times per day.

Demonstrate if at all possible.

10. The kits will readily adapt to using the bread as a “nursery,” and bottle feeding can be gradually discontinued.
11. The young will start eating rolled oats at 14 to 21 days old.
12. After 21 days, start feeding rolled oats/pelleted feed mixture. The diet can consist of totally commercial pellets at approximately 30 days of age.

THE FORMULA FOR THE ORPHANED RABBITS

Demonstrate how to prepare the formula.

Ingredients:

- 1 pint 2% milk
- 2 egg yolks
- 2 Tablespoons powdered milk
- 2 Tablespoons corn syrup
- 1 teaspoon bone meal

Put all the ingredients into a bowl and mix thoroughly with a spoon. Keep the formula refrigerated. Warm small portions to 90°F as needed.

DIALOG FOR CRITICAL THINKING:

- Q: We use foster care to care for children who need temporary homes.
- Discuss the benefits of foster care as you understand it. If we didn't have foster care for children, what choices would be available?
 - Discuss the advantages and the disadvantages of foster care.

GOING FURTHER:

1. Invite a rabbit breeder who has reared orphaned kits to come to your meeting.
2. Ask a social worker to explain foster care procedures for children.
3. Ask a foster parent to speak with your group.

Leader Notes



Culling Rabbits Through Records

Rabbits, Level 3, Activity 14

What Members Will Learn . . .

ABOUT THE PROJECT:

- To use records to cull their herds

ABOUT THEMSELVES:

- The importance of being organized

Materials Needed:

- Doe Breeding Record
- Buck Breeding Record

ACTIVITY TIME NEEDED: 30 MINUTES

ACTIVITY

Leader Notes

You must constantly cull those rabbits that are not producing up to their potential. Records will allow you to use objective facts when culling the herd.

A Red New Zealand doe #345 was born 6-7-86. Her sire is #34, her dam is #45, and she was born in litter 3.

#345 was bred 1-8-87 to buck 34. She kindled 2-7-87. Five live young, one dead young, five were weaned on 3-21-87, total weight of the litter was 16 pounds.

#345 was rebred 3-7-87 to buck 45. She kindled 4-7-87. Nine live young were born, no dead young, eight were weaned on 6-7-87, total weight of the litter was 35 pounds.

#345 was bred 5-24-87 to buck 34. She kindled 6-24-87. Four young were born, there were two dead young, four were weaned on 8-24-87, total weight of the litter was 20 pounds.

#345 was bred 9-1-87 to buck 45. She kindled 10-2-87. Eleven live young were born, two dead young, eight were retained and three fostered off, eight were weaned 12-8-87, total weight of the litter was 36 pounds.

Should we keep the doe in our herd?

Answer: She has kindled four times and weaned a total of 25 rabbits for an average of 6.25 per litter. However, we must note that when bred to

Hand out the breeding records. Explain that you can cull both bucks and does using records. Use the records for does and have them record the information you read to them.

Ask the members to answer the question. Discuss the reasons for keeping the doe.

Leader Notes

Use the buck breeding record. Have the members record the information as you read it to them.

buck 34 she had smaller litters. Therefore, she should be kept in the herd. We should check out buck 34.

Does should average seven to eight young to be weaned from each litter in order to be kept in the commercial rabbitry. Does of fancy breeds will have smaller litters.

Using the buck records, we see that buck #34 is a Red New Zealand. #34 was born 2-3-86. His sire is #4 and his dam is #35.

#345 was bred 1-8-87, five live young and one dead young were kindled, four were weaned, total weight of the litter was 16 pounds.

#26 was bred 1-20-87, four live young born, four were weaned, total weight of the litter was 23 pounds.

#345 was bred 5-24-87, four live young and two dead young were kindled, four young weaned, total weight of the litter was 20 pounds.

Should we keep 34 in the herd?

Ask members this question. Discuss the reasons for their answers.

Answer: No, if we are raising rabbits commercially. If fryers are why we are raising rabbits, we will raise more rabbits using a different buck. If #34 was a fancy rabbit, the size of his litters is acceptable.

DIALOG FOR CRITICAL THINKING:

Q: Good record-keeping is a part of being organized. You can see how important this organization is in running a successful rabbitry.

Discuss the importance of organization and/or record-keeping as it relates to your school work. In what other areas of your life is being organized important? Does being unorganized mean you cannot be successful? What are the benefits of being organized?

GOING FURTHER:

1. Have the 4-H'ers use records to cull their herds.
2. Computerize your records to help you cull your herd.
3. Visit a commercial rabbitry and see how they use records to cull.

CULLING RABBITS THROUGH RECORDS

Activity Sheet

Doe Breeding Record

Doe No. _____ Born _____ Breed _____

Sire _____ Dam _____ Litter No. _____

Date Bred	Date Due	Buck No.	Date Kin- dled	No. Young Born		Number Young Retained	Litter No.	Date Weaned	No. Weaned	Weaning Wt.
				Alive	Dead					

Buck Breeding Record

Doe No. _____ Born _____ Breed _____

Sire _____ Dam _____ Litter No. _____

Doe	Date Bred	Result of Breeding			Weaned		Notes
		Kindled		Passed	Number	Weight	
		Alive	Dead	Date			

Leader Notes



When to Remate the Doe after Kindling

Rabbits, Level 3, Activity 15

What Members Will Learn . . .

ABOUT THE PROJECT:

- The factors that determine when rabbits should be remated
- The best times to remate doe after kindling

ABOUT THEMSELVES:

- Their feelings about a proper diet and weight for their age

Materials Needed:

- Chalkboard or flip chart

ACTIVITY TIME NEEDED: 20 MINUTES

ACTIVITY

Leader Notes

You need to know when to breed your does after they have kindled. The length of time allowed to elapse from the time the doe kindles until she is remated varies considerably depending upon the circumstances. Several factors determine the length of time between kindling and remating:

List these on the chalkboard or flip chart.

1. The total number of young being raised by the doe.
2. The intended production purposes of the doe and litter.
3. The genetic ability of the doe to maintain physical condition during lactation.

You must decide the individual rabbit's physical condition. Can the doe withstand remating, gestation, and lactation at this time? This will vary from doe to doe and upon the desired goals of production.

Once a doe is in production, ideally it is best to keep the rabbit in production in order to minimize reproductive problems.

Excessive fat accumulation within the doe's abdominal cavity is the number one cause of breeding difficulties.

Most 4-H'ers do not realize the small amount of feed needed to maintain a resting doe and therefore overfeed her.

Excessive fat accumulation in the abdominal cavity acts as a physical barrier to prevent the egg (ovum) from entering the reproductive tract to

Leader Notes

be fertilized. Thus, the conception rate is drastically reduced. Obese does exhibit decreased receptiveness to the buck.

The doe is usually more receptive to the male about 72 hours after kindling.

Some rabbit breeders recommend that the producing doe be remated two weeks prior to weaning the litter.

The doe can be palpated for pregnancy 12 to 14 days after mating, and if the doe is pregnant, the litter can be weaned and then she will have two weeks to recuperate before kindling the next litter.

If the palpated doe is not pregnant, she can be remated immediately and the litter left with the doe for two more weeks. If the doe fails to conceive the second time, she should be labeled a problem breeder. Try to make sure that the doe becomes pregnant.

Ideally, the doe should be bred and diagnosed as pregnant prior to weaning. Consider each doe as an individual and remate her for the specific conditions that exist. Let us consider some specific situations:

DOES WITH COMPLICATIONS: These include difficult births, reproductive infection, respiratory infection, ketosis, etc. It is important to identify problems and take precautions to prevent them from recurring.

WHEN ONLY ONE TO THREE LITTERS PER YEAR ARE DESIRED: Do not let the doe become fat. Feed her a restricted diet to maintain good breeding condition.

DOES THAT LOSE THE ENTIRE LITTER: If no complications are present, does that lose their litters during kindling or shortly after kindling should be remated three to seven days after kindling. If the doe loses her litter during the lactation, remate her immediately.

DOES WITH SMALL LITTERS: Occasionally a doe has twins or triplets and there isn't any chance to foster the young to another doe. Remate the doe 14 days after kindling. Wean the young at five weeks of age and given them some special creep feed after weaning to keep growing.

DOES WITH EXTREMELY LARGE LITTERS: Does with extremely large litters may have a deteriorated flesh condition and should not be remated until they have recovered. The litter may need to be weaned in order for the doe to recuperate before being remated.

GENERAL GUIDELINES:

When to Breed:

1. Does that lose their litters at or during kindling (no complications) 3 to 7 days
2. Does with very small litters 14 days
3. Commercial production does 10–21 days
4. Commercial/fancy rabbits 2 weeks prior to weaning
5. Does with complications when appropriate for specific problem

List this summary on chalkboard or flip chart.

Have the members tell what breeding schedule they are using and discuss why.

DIALOG FOR CRITICAL THINKING:

Q: The weight and fat that a rabbit carries is important to reproduction. Your own weight and the amount of fat you carry is important to consider, too. Discuss the problems involved in being overweight.

Q: What kind of diet is most beneficial for you? What factors influence how much you eat?

GOING FURTHER:

Develop a feeding schedule for nonpregnant does.

Leader Notes



Determining When to Breed to Produce Rabbits for Various Show Classes

Rabbits, Level 3, Activity 16

What Members Will Learn . . .

ABOUT THE PROJECT:

- How to plan breeding so rabbits will be the right show age

ABOUT THEMSELVES:

- Their feelings about family planning
- To recognize problems associated with family planning

Materials Needed:

- Chalkboard or flip chart
- Paper and pencils
- Calendars

ACTIVITY TIME NEEDED: 30 MINUTES

ACTIVITY

Leader Notes

In order to have rabbits the right age for showing at the county fair or other shows, it is important to know when to breed your rabbits.

You want to show some Californians in the 6-to 8-month classes at the county fair. When should you breed so your rabbits will be the right age?

Answer: The county fair is held July 20–25. You will want your rabbits to be about 6½ months old. Since it takes about 30 days for gestation, you will need to breed your rabbits 7½ months before the fair.

When should you breed so you can show in the junior classes?

Answer: Juniors must be under 6 months of age. You probably would like to have them at least 4½ months old. Therefore, you should breed your rabbits any time between January 5 and February 5. If you breed January 5 the rabbits will be 5½ months old.

The state fair 4-H rabbit show is September 15. When should you breed so you will have a meat pen rabbit for the state fair?

Answer: Meat pen rabbits must not be over 70 days of age. Count back 70 days and add 30 days gestation time. You should breed your rabbits no earlier than June 7.

Pass out the calendars, pencils, and paper and see if the 4-H'ers can come up with a date. Answer: December 5.

Leader Notes

The annual county 4-H spring show is to be held May 20. What classes can you enter your rabbits in from the following breedings?

Doe	Date Bred
Black Dutch #45	November 25
Blue Satin #56	October 12
White New Zealand #32	January 15
Californian #B54	February 15

Answer: Black Dutch doe should have kindled December 25. The offspring would be almost 5 months old, and could be shown as juniors.

The Blue Satin Doe should have kindled November 11. The offspring would be over 6 months of age and should be shown in the 6-to 8-month classes.

What if one of the Blue Satin bucks weighs 9 pounds?

Answer: You should show him as a senior buck.

The New Zealand White doe should have kindled by February 14. Therefore, the offspring are over 3 months of age. Enter them in the junior classes.

Now have the members plan when they need to breed for their county fair.

The Californian doe should have kindled March 17. The offspring would be 64 days old; they can be shown in the meat pen class and as pre-juniors.

DIALOG FOR CRITICAL THINKING:

Q: Planning the births of your rabbits is important to your project. Planning the births of your future children is even more important. Discuss reasons why you should plan when and how many children you should have. What steps can you take to meet this plan? What kind of things could happen to interfere with your family plan?

GOING FURTHER:

Although there is a variation of $8\frac{1}{2}$ to $10\frac{1}{2}$ months gestation for humans, the approximate time is 295 days. Figure the approximate date of your conception based on a 295-day gestation period.



Formulating Rabbit Show Classes

Rabbits, Level 3, Activity 17

What Members Will Learn . . .

ABOUT THE PROJECT:

- The various classes they may enter rabbits in at an ARBA sanctioned show

ABOUT THEMSELVES:

- To understand and evaluate the effects of classifying people

Materials Needed:

- Chalkboard
- Rabbit classes from your local fair book or show
- State fairbook or state fair rabbit entry form

ACTIVITY TIME NEEDED: 30 MINUTES

ACTIVITY

Leader Notes

There are several classes you can enter at a rabbit show. However, some shows will not have all these classes available.

In order to find out what classes are available, we need to know if you are showing six class or four class rabbits.

Six class rabbits are larger with the ideal weight of the senior animals being nine pounds or more. They have three age groups for each sex.

Classes for six class rabbits are:

Senior Buck
Senior Doe
Intermediate Buck (6 to 8 months)
Intermediate Doe (6 to 8 months)
Junior Buck
Junior Doe

A few of the six class rabbits also have:

Pre-junior Buck
Pre-junior Doe

Not all six class rabbits have pre-junior classes. For instance, the French Lops do not have pre-junior classes.

List the classes as you discuss each of them. Compare your local classes with those at the State Fair and other shows.

Leader Notes

In what classes can the four class rabbits be exhibited? Four class rabbits are smaller with the ideal weight of the senior animals being less than nine pounds. They have two age groups for each sex.

Classes for four class rabbits:

Senior Buck
Senior Doe
Junior Buck
Junior Doe

Then there are the fur and wool classes:

Breed fur classes
Normal White Fur class
Normal Colored Fur class
White Satin Fur class
Colored Satin Fur Class
Colored Rex Fur class
White Rex Fur class
English Angora White Wool class
English Angora Colored Wool class
French Angora White Wool class
French Angora Colored Wool class
Giant Angora White Wool class
Giant Angora Colored Wool class

The normal colored and normal white fur classes are used only occasionally at local ARBA-sanctioned shows, but these are the fur classes used at 4-H shows. Generally at an ARBA-sanctioned show, the rabbits are exhibited in breed fur classes instead of the normal fur classes.

Then there are the meat classes:

Meat Pen
Single Fryer

DIALOG FOR CRITICAL THINKING:

Q: For many reasons, different classes of animals are acceptable and desirable. Making distinctions between people and classifying them is not usually acceptable. Discuss the problems with classifying and thus stereotyping individuals. Are there ever instances where classifying is desirable?

GOING FURTHER:

Identify breeds of rabbits that are four or six class according to weight.



Talking Like a Rabbit Judge

Rabbits, Level 3, Activity 18

What Members Will Learn . . .

ABOUT THE PROJECT:

- The vocabulary/terms used by rabbit judges

ABOUT THEMSELVES:

- To discover the importance of knowing terms and vocabulary in any area of life

Materials Needed:

- Glossary (or selected terms) for each member
- Cards with different rabbit terms listed on them
- Cards with the definitions of the rabbit terms

ACTIVITY TIME NEEDED: 40 MINUTES

ACTIVITY

You must be able to understand the terms used by rabbit judges if you want to know how to judge good and poor rabbit characteristics.

DIALOG FOR CRITICAL THINKING:

Q: Knowing correct terms in any endeavor is important. Imagine going to a doctor who didn't know the correct terms. Think about the lawyer, chemist, or farmer who uses terms incorrectly or not at all. How would you feel about dealing with people like this?

Leader Notes

Divide the group into teams. Give each team a set of cards with terms and definitions. See if they can match the definitions with the correct terms. Give the members the correct answers (Glossary of Rabbit Terms).

Now play a game. Read the definition of a term and see which team can give the term. Keeping score gives the 4-H'ers a chance to see how well they know rabbit terms.

Now select a term and ask the members to use it in a sentence. Continue until every 4-H'er has a chance to participate.

Leader Notes



Presenting Oral Reasons

Rabbits, Level 3, Activity 19

What Members Will Learn . . .

ABOUT THE PROJECT:

- The steps used when giving oral reasons

ABOUT THEMSELVES:

- The importance of reserving judgment
- How they feel about being judged on their appearance by others

MATERIALS NEEDED:

- A class of rabbits to be judged
- Judging cards

ACTIVITY TIME NEEDED: 60 MINUTES

ACTIVITY

Leader Notes

Even if you can place a class of rabbits correctly, you must know why you placed the class as you did and be able to explain the reasons for your decisions.

Remind the 4-H'ers that there are several things to look for when judging a class of rabbits.

Points to Consider when Judging Rabbits

- I. Body Conformation
 - A. Firm body—not overly fat
 - B. Well-balanced
 - C. Rump well-rounded; smooth (shaped like half-basketball)
 - D. Wide, meaty loin
 - E. Full front shoulders
 - F. Short neck—well-placed head
- II. Other Features
 - A. Erect ears—balanced to body (not too long or too short).
Exception: lop-eared rabbits.
 - B. Straight leg bone (Not cow-hocked or bowlegged)
 - C. Fur: condition—tight fur, no breaks, stains or mats
 - D. The rabbit should be free of disqualifications and eliminations.

Class refers to what you are judging—in this case, Dutch.

Hand out “Sample Judging Class” sheet. The sheet has a class of Dutch rabbits for us to judge. Discuss the judging card.

Constant number refers to the number you were given when you registered.

Remember to circle your placing of the class—Here you would want to circle 2-4-1-3.

Leader Notes

Remember to hand in the card to the person in charge. The scorer or reasons judge will fill in the rest of the card.

Discuss the steps in giving oral reasons.

GIVING ORAL REASONS

1. Opening statement—Name of class and order of placing.

I placed this class of Dutch Senior Does 2-4-1-3.

2. General statement—How you felt about the class.

I thought it was a fairly hard class to judge because all except number 2 have obvious disqualifications.

3. Reasons for top pair—Comparison.

Number 3 was the poorest animal.

I placed 2 over 4 because 2 is more perfectly marked, correct color with no runs in saddle area. Both 2 and 4 show proper body conformation, color, erect ears, correct size, and weight with well-rounded hips and shoulders.

Criticism of second animal in the pair.

However, number 4 has a white tail and a black front foot.

4. Reasons For Middle Pair—Comparison.

I placed 4 over 1 because 1 has color running into the saddle. Number 4 is better marked.

Describe good things about second rabbit in pair.

I grant that 1 is correct in size and weight.

Give criticism of second animal in pair.

But I criticize 1 because it has color running into the saddle and on two feet, flat hips and short ears. Number 1's head is not a good shape and face is poorly marked. She has a white tip on the tail.

5. Reasons for bottom pair—
Comparison

Give criticism of second
rabbit in pair.

I placed 1 over 3
because of weight,
size and body
characteristics.

I place 3 last and
at the bottom of the
class because she is
obviously a cross
breed. She shows
definite Californian
body lines, ears and
weight. She is poorly
marked with none of
the Dutch characteristics.

6. Closing statement

Therefore, I placed
this class of Dutch
Senior Does 2-4-1-3.

This is not a very good class. All but number 2 have disqualifications. After you have selected 2 for your top placing, body type becomes the important factor.

Now hand out the judging cards and have the group judge the class. After each member has placed the class have the members give oral reasons. (You may need to use several older members or parents here.)

DIALOG FOR CRITICAL THINKING:

Q: Judging animals is one thing, but judging people is another. What things can you tell about people solely by the way they look?

Remember a time when you made a judgment about someone and found out later that you were wrong. What did you learn from this experience? There is an old saying that, “You can’t judge a book by its cover.” How does that saying relate to this topic?

GOING FURTHER:

Participate in a rabbit judging contest.

SAMPLE JUDGING CLASS

Activity Sheet

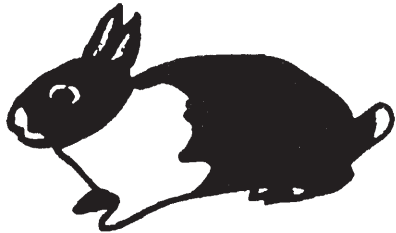

1

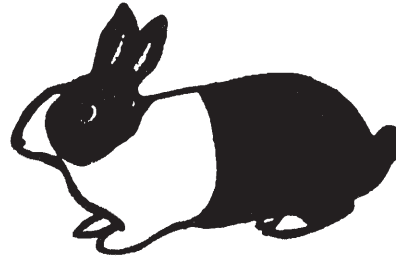

2

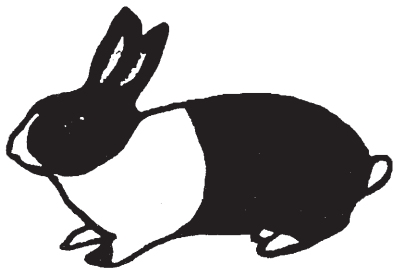

3



4

In judging rabbits, look for the characteristics of the breed: size, shape, color, correct markings, body conformity, weight, etc. Study the classes, select the best rabbit, second best, third best, and poorest.

Now look at the card used for placing and scoring a judging event. Place the class and fill out the card.

On this page, the traditional approach to judging is shown using the four-animal class. In real life, you may select from many animals, both your own and/or those of other breeding establishments. Using this approach, practice evaluating groups of animals and answering questions about their strengths and weaknesses on important factors.

4-H JUDGING CARD

	Circle Your Placing	Official Score
A	1234	
B	1243	
C	1324	
D	1342	
E	1423	
F	1432	
G	2134	
H	2143	
I	2314	
J	2341	
K	2413	
L	2431	
M	3124	
N	3142	
O	3214	
P	3241	
Q	3412	
R	3421	
S	4123	
T	4132	
U	4213	
V	4231	
W	4312	
X	4321	

Contestant No. _____

Class No. _____

Class Name _____

Reasons Score _____



Scoring a Judging Class

Rabbits, Level 3, Activity 20

What Members Will Learn . . .

ABOUT THE PROJECT:

- How to score a class by hand
- How to use the Hormel computing slide

ABOUT THEMSELVES:

- Their leadership qualities
- How responsible they are and how important responsibility is

Materials Needed:

- Hormel computing slide(s)
- Judging cards
- Pencils

ACTIVITY TIME NEEDED: 30 MINUTES

ACTIVITY

Leader Notes

Often youth leaders are called upon to help with various judging events. One of the events is the scoring of the contestants' score cards.

SCORING A CLASS

Two methods are available to score the 4-H'er's placings:

1. Score it themselves.
2. Use the Hormel computing slide either directly or make a key to use with the 4-H Judging Card.

Score it themselves

Members may score their own classes by knowing the official placings and cuts. Here's how this works:

Example 1: Official Placing 1 - 3 - 2 - 4. Cuts 5 2 6

4-H'er's placing: 2 - 4 - 3 - 1. Simply compare the 4-H'er's placing to the official placing and ask six questions—one for each possible pair. Every time the answer is “no” in relation to the value of the cuts, points are lost for all pairs involved.

Leader Notes

Q: Did I place 1 over 3 (like the official judge did)?	
A: No, so I lose	5 points
Q: Did I place 1 over 2?	
A: No, so I lose	5 + 2 points
Q: Did I place 1 over 4?	
A: No, so I lose	5 + 2 + 6 points
Q: Did I place 3 over 2?	
A: No, so I lose	2 points
Q: Did I place 3 over 4?	
A: No, so I lose	2 + 6 points
Q: Did I place 2 over 4?	
A: Yes, so I don't lose points.	_____
Total:	35 points lost

50
-35
 15 is 4-H'er's score_

Provide several combinations of placings and cuts. Let members figure scores until they are comfortable with the method. Other variations may be taught with same results.

Example 2: If 4-H'er's placing was 3 - 1 - 4 - 2 what would the score have been on this same class?

Answer: (-5, 0, 0, 0, 0, -6)
 50
-11
 39 is 4-H'er's score (simply reversed both pairs)

USING THE HORMEL COMPUTING SLIDE

1. Given the official placings and cuts used above, find the 1 - 3 - 2 - 4 placings at the top of one of the columns of the plastic overlay cards.
2. Locate the listing of the scores desired by adding the cuts ($5 + 2 + 6 = 13$), finding this total at the top corner of one of the white cards with the black scores, and locating the correct combination of three cuts at the bottom of the card.
3. Place the correct column of placings beside the indicated combination of scores. Double-check before transferring.
4. Make a key out of one of the Judging Placing Cards.

Now give the 4-H'ers different official placings and cuts and have them score the judging score cards. Continue until all understand how to use the Hormel computing slide.

DIALOG FOR CRITICAL THINKING:

Your role in 4-H has changed over the years from a participant actively learning new things to one of helping others participate by taking leadership roles.

Q: Discuss the qualities of a good leader. Evaluate how many of these qualities you have. What can you do to develop those qualities you do not possess?

Q: Responsibility is important whether you lead or are part of a group. How have your responsibilities changed over the years? How do you expect them to change in the future (be specific)? What are some consequences (results) you experienced when you have not been responsible?

GOING FURTHER:

Set up and run an entire judging contest with several classes and oral reasons.

Leader Notes



Determining a Rabbit's Condition

Rabbits, Level 3, Activity 21

What Members Will Learn . . .

ABOUT THE PROJECT:

- To know what to look for in a well-conditioned rabbit

ABOUT THEMSELVES:

- The importance of their own physical and mental condition

Materials Needed:

- Rabbits in different conditions

ACTIVITY TIME NEEDED: 30 MINUTES

ACTIVITY

Leader Notes

Condition refers to the condition of the fur and flesh. Examine your rabbit. Is the fur free of moult, shiny, and does it return to its natural position when stroked in the opposite direction? The coat should be shiny, free of stain and moult.

Run your hand over the body of your rabbit. Does the body feel smooth without any bones protruding? Or, is the rabbit like a washboard? A rabbit in good condition should be firm of flesh and feel smooth when a hand is run over the body.

A rabbit may have excellent fur condition but poor flesh condition. Some strains of rabbits never develop good flesh condition.

A rabbit may have good flesh condition but the coat isn't finished. The fur doesn't return to its natural state when stroked towards the head. The fur may be in a state of moult. A few rabbits never seem to have finished fur.

Sometimes the word "finish" is used for condition. When we talk about the finish of a market animal, we usually are talking about the flesh condition. A finished coat is free of stains, moult, and is shiny and full of life.

Now have the 4-H'ers examine the rabbits present. Have the 4-H'ers determine the fur and flesh condition of each rabbit.

Leader Notes

DIALOG FOR CRITICAL THINKING:

Q: What things do you look for in humans that let you know they are in “good condition”? Discuss this in physical terms and then emotional terms. How related are the physical and emotional conditions? Must you be in good physical condition to be emotionally healthy or vice versa?

GOING FURTHER:

Find out why some rabbits do not develop good flesh condition.



Figuring Dressing Percentages and Average Daily Gain

Rabbits, Level 3, Activity 22

What Members Will Learn . . .

ABOUT THE PROJECT:

- How to determine the average daily gain
- How to figure dressing percentage

ABOUT THEMSELVES:

- How dressing percentage relates to the human body

Materials Needed:

- Scales
- Fryers
- Calculator
- Equipment to process the fryers (optional)
- Chalkboard or flip chart

ACTIVITY TIME NEEDED: 60 MINUTES

ACTIVITY

Leader Notes

You need to know how well your rabbits are producing. The dressing percentage and average daily gain are good indications of the success of your rabbit production.

The average daily gain is easy to figure if you have the weight of the rabbit and its age. Divide the weight of the fryer by the age of the rabbit. For example, if a rabbit weighs 4½ pounds and is 60 days old, the average daily gain is 0.075 pound/day.

$$(4\frac{1}{2} \text{ pounds}/60 \text{ days}) = 0.075$$

Did all the fryers have the same average daily gain?

If you were going to keep some of these fryers for commercial rabbitry, which ones would you keep?

To determine the dressing percentage, you need to have the weight of the live rabbit and the weight of the carcass. Leave the liver, heart, and kidneys in the carcass when determining dressing percentage.

To calculate the dressing percentage, divide the weight of the carcass by the weight of the live rabbit and multiply by 100 percent. If your

Use a chalkboard to demonstrate this and other math problems.

Now weigh a fryer and give the members the age of the rabbit. Have the members calculate the average daily gain. Continue until all the fryers have been weighed and the average daily gain calculated.

At this point you will want to dress the fryers. However, if it isn't possible to dress the rabbits, you still can study the dressing percentage.

Leader Notes

live rabbit weighs 4.5 pounds and the carcass weighs 2.30 pounds, your dressing percentage is 51.1 percent.

Have members calculate dressing percentages for the following:

	Live Weight	Carcass Weight
Rabbit I	5.05 lbs	3.10 lbs
Rabbit II	4.85 lbs	2.76 lbs
Rabbit III	4.24 lbs	2.05 lbs

Answers:

Rabbit I	$(3.10/5.05) \times 100\% = 61.4\%$
Rabbit II	$(2.76/4.85) \times 100\% = 56.9\%$
Rabbit III	$(2.05/4.24) \times 100\% = 48.3\%$

We want rabbits that have a large dressing percentage and a large average daily gain for a successful rabbitry.

If you dressed the fryers and calculated the dressing percentage for them, compare the dressing percentage with the average daily gain. Did the fryer with the best average daily gain have the best dressing percentage?

DIALOG FOR CRITICAL THINKING:

Q: Take the information you know about dressing percent (muscles are more dense so weigh more than fat) and discuss how you can relate this to the human body. How do you think you would “dress out?”

GOING FURTHER:

1. Have the members calculate dressing percentage and average daily gains for their rabbits.
2. Check your medical and/or school records to see how much weight you’ve gained in a year. Figure your own average daily gain.



Home Processing a Rabbit

Rabbits, Level 3, Activity 23

What Members Will Learn . . .

ABOUT THE PROJECT:

- Equipment needed in slaughtering and skinning
- Steps in slaughtering and skinning a rabbit

ABOUT THEMSELVES:

- How to accept loss

Materials Needed:

- Rabbit fryer
- Sharp knife
- A bucket of water
- A bucket of ice water
- Trash can and trash bags
- Freezer wrap

ACTIVITY TIME REQUIRED: 30 MINUTES

ACTIVITY

Leader Notes

The best way to learn how to dress a rabbit is by watching someone demonstrate the proper procedure.

1. Killing the rabbit—Stun the rabbit by hitting it with a stick at the base of the skull behind the ears. Another method is breaking the neck. Press the base of your thumb against the back of the rabbit's head while grasping the hind legs in your other hand. Bend head back as far as possible and pull with both hands until you feel the head break away from the neck.
2. Suspending and bleeding—Suspend the rabbit by both hind feet immediately and remove the head so the carcass will bleed thoroughly. A #6 screw hook fastened to a wall 5 feet above the floor is good for this purpose. Insert the hook between the tendon and bone of the right hind leg just above the hock.
3. Cut off the tail and front feet.
4. Free and remove rear foot at the hock joint.
5. Cut the skin just below the hock of the suspended leg and open it inside the leg to the root of the tail and to the left hock joint.

Leader Notes

6. Separate the edges of the skin from the flesh and pull the skin down off the carcass.
7. Set the pelt aside if you wish to tan or dry it.
8. Make a slit in the carcass along the median line of the belly. Remove the entrails. You may wish to leave the heart and kidneys. Save the liver but always remove the gall bladder.
9. Remove the right hind foot at the hock.
10. Clean the carcass by rinsing in cold water to remove stray hairs and blood.
11. Cool the carcass for 15 minutes in ice water.
12. Cut up the carcass if desired.
13. Wrap in freezer wrap and freeze.

DIALOG FOR CRITICAL THINKING:

Q: How do you think it will feel to slaughter a rabbit you have cared for?

If this will be difficult, what will make it so? Will you miss the rabbit? What can you do to make the loss easier to accept?

Q: Some people are against slaughtering animals and eating meat. Why do you think they might feel this way? How do you feel about it?

GOING FURTHER:

1. Visit a rabbit processing plant.
2. Have the members try to dress a rabbit at home or at this meeting.

STEPS IN SLAUGHTERING A RABBIT

Activity Sheet

Leader's Key

Number the steps below in the correct order.

- _____ Cut off tail and front feet
- _____ Remove the skin from the flesh
- _____ Kill the rabbit
- _____ Cool the carcass in ice water
- _____ Remove the entrails from the carcass
- _____ Suspend the body and bleed it by removing the head
- _____ Clean the carcass by rinsing it
- _____ Freeze
- _____ Remove free hind foot
- _____ Cut the skin
- _____ Remove the last foot

STEPS IN SLAUGHTERING A RABBIT

Activity Sheet

Number the steps below in the correct order.

- 3 Cut off tail and front feet
- 6 Remove the skin from the flesh
- 1 Kill the rabbit
- 10 Cool the carcass in ice water
- 7 Remove the entrails from the carcass
- 2 Suspend the body and bleed it by removing the head
- 9 Clean the carcass by rinsing it
- 11 Freeze
- 4 Remove free hind foot
- 5 Cut the skin
- 8 Remove the last foot

STEPS IN RABBIT DRESSING—Activity Sheet

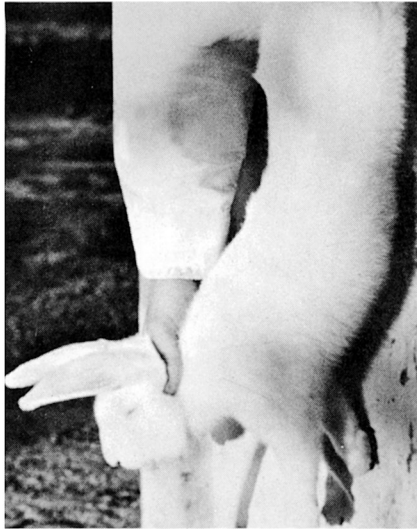

1. Kill rabbit by breaking its neck. Press base of your thumb against back of rabbit's head. Bend head back as far as possible. Pull until you feel head break away from neck. There are other methods which you may wish to use.

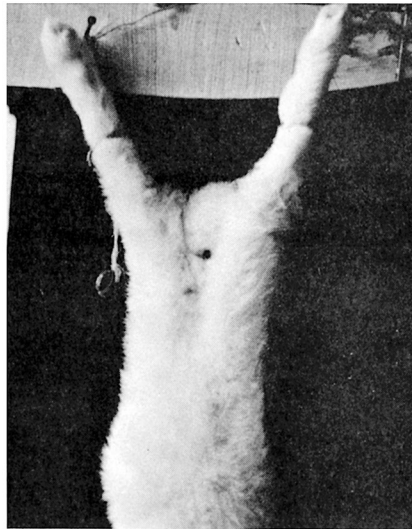

2. You may hang your rabbit with both hind feet. This is recommended.

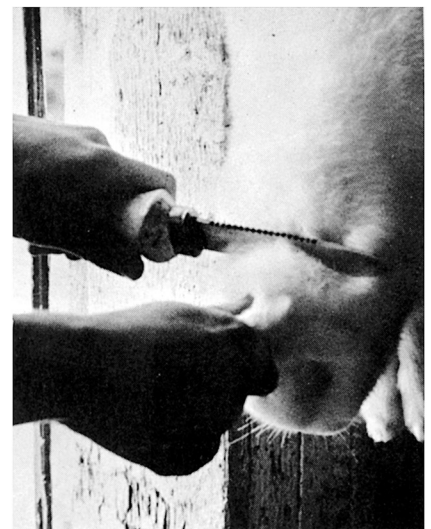

3. Immediately cut off head. Cut close to head and through the place where head was broken away from neck.



4. Cut off both feet. Then unhook the right hand foot and cut it off.



5. With a chicken-sticking knife, slit skin up inside of both hind legs.



6. Tear hide away from hind leg on hook.



7. Tear hide from tail and vent by working fingers between hind and body ahead of tail and over rump.



8. Force fingers between hide and body and pull hide from free hind leg.



9. Cut as shown, leaving the fat on the flanks, not on the pelt.

STEPS IN RABBIT DRESSING—Activity Sheet



10. As soon as the whole pelt can be held with one hand, remove it with one strong pull.

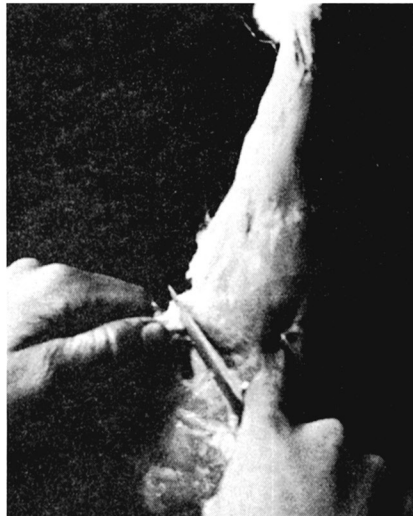

11. Cut off tail.

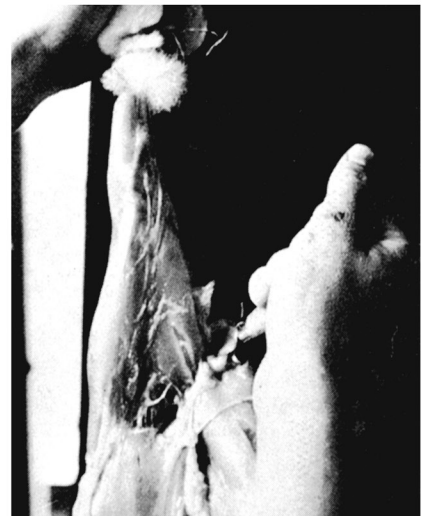

12. Cut pelvic bone between hind legs by inserting knife from above and prying out.



13. Slit down belly, being careful not to cut bladder, intestines, or stomach.



14. Pull out insides by grasping stomach and holding liver in place with thumb of other hand. Carefully remove gall bladder without cutting or breaking it. The bitter green bile of the gall bladder must not be spilled on the meat.

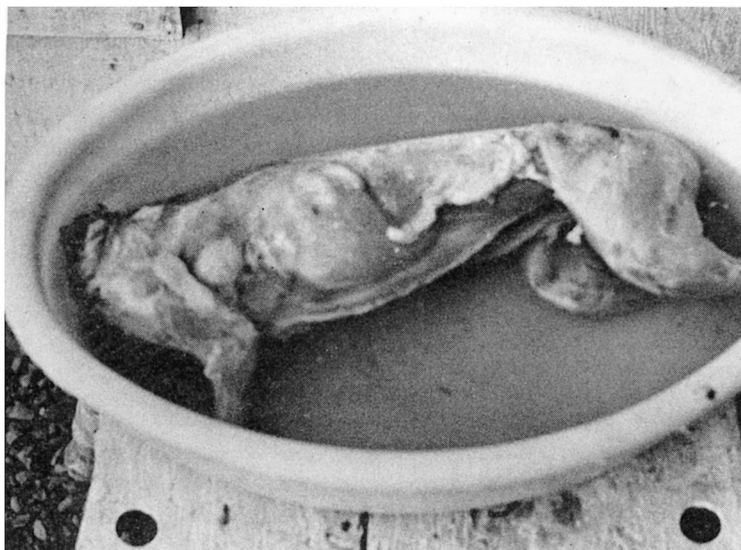

15. Wash the carcass in cold water. It may be left in cold water for 15 minutes for cooling. Remove and place in a pan or wire basket in a natural position.

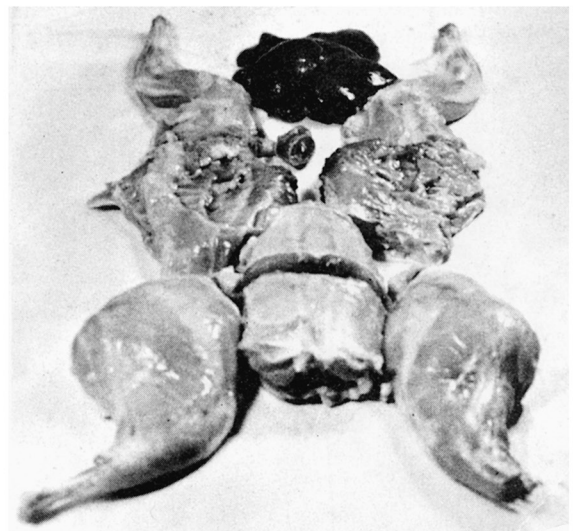

16. One method of cutting up a fryer rabbit. Rabbits are usually marketed as a cut up fryer rather than whole.



Cutting Up and Wrapping a Rabbit Carcass

Rabbits, Level 3, Activity 24

What Members Will Learn . . .

ABOUT THE PROJECT:

- How to cut up a rabbit
- How to wrap the rabbit and make it attractive to the customer

ABOUT THEMSELVES:

- To understand how they feel about eating rabbits and other meats

Materials Needed:

- Rabbit carcasses
- Sharp knives
- Cutting board
- Styrofoam meat trays
- Plastic wrap
- Parsley

ACTIVITY TIME NEEDED: 60 MINUTES

ACTIVITY

Leader Notes

You should know how to prepare rabbits for customers since many people wish to have the rabbit cut into pieces ready to cook.

Demonstrate how to cut up a rabbit carcass.

STEPS IN CUTTING UP A RABBIT CARCASS

1. Start with a front leg. Pull the leg out and with a sharp knife cut through the shoulder joint. Twisting the leg helps to locate the joint.
2. Repeat with the other front leg.
3. Pull out a rear leg and cut where the thigh joins at the hip joint. Again, twist to help locate the joint. Leave the thigh and hind leg in one piece.
4. Repeat with the other hind leg.
5. Cut the carcass through the backbone just where the rib cage ends.
6. Slice along the cartilage that joins the ribs and backbone. This makes two pieces of ribs.

If enough carcasses are available, let each member cut a carcass while following your demonstration.

Leader Notes

Demonstrate wrapping step by step.
Let members wrap their cut carcasses.

7. Cut the rear section of the back if desired.
This is the loin and is considered the best portion of the rabbit.

Now you are ready to package the rabbit. If you are selling fresh rabbit meat, you will want to make it look attractive. Arrange the pieces on a styrofoam tray and garnish with parsley. Now wrap with plastic wrap.

If you are selling frozen meat, you should use freezer wrap to prevent freezer burn and loss of palatability.

DIALOG FOR CRITICAL THINKING:

Q: Eating rabbit meat is the same as eating cows and chickens but because of the image of rabbits as cute little bunnies some people are more upset by it. How would you respond to this criticism?

Q: Some people criticize eating any meat at all. How would you respond to people who believe you should not eat any meat?



Caring for a Rabbit Pelt

Rabbits, Level 3, Activity 25

What Members Will Learn . . .

ABOUT THE PROJECT:

- How to dry and store a pelt

ABOUT THEMSELVES:

- To evaluate the importance of following directions

Materials Needed:

- Pelt stretchers
- Pelts that have been dried
- Naphtha flakes

ACTIVITY TIME NEEDED: 30 MINUTES

ACTIVITY

Leader Notes

Rabbit pelts can be an additional source of income. But, pelts not cared for properly are worthless.

While the skin is still warm, place it on a stretcher, secure it with clothes pins and hang up to dry.

Place the flesh side out with forepart over the narrow end of the stretcher.

Keep the legs on one side, thus avoiding any possible damage to the back fur.

Remove all wrinkles.

Even though the shaper is called a stretcher, the skins should not be stretched excessively since stretching tends to weaken certain parts and to open the fur.

After one day examine the pelt to see that the edges are drying flat and that the skin on the front legs is straight.

Do not dry the pelts in the sun or with artificial heat.

Hang the pelts so that air freely circulates around them.

Remove all the fat from the pelts.

This lesson should be done in conjunction with lesson on home processing a rabbit.

Demonstrate to the members how to stretch a fresh pelt.

If enough rabbits are processed, let each member stretch and prepare a fresh pelt.

Leader Notes

All pelts must be thoroughly dry before they are packed.

If the pelts are not to be shipped for some time, hang in loose bundles of 50 in a cool, dry place.

Keep pelts where rats and mice cannot reach them.

If pelts are to be kept any length of time in a warm climate or during the summer, sprinkle them with Naphtha flakes.

Have the members look at the stretchers and pelts.

Salt should never be used to dry rabbit skins.

DIALOG FOR CRITICAL THINKING:

Q: Following directions is important in drying rabbit pelts. In what other aspects of your life is following directions important? What has happened to you when you haven't followed directions? What problems have you seen adults encounter because they haven't followed directions?

GOING FURTHER:

1. Practice actually drying a pelt.
2. Have each member bring a pelt to a meeting and practice judging each other's pelts.



Tanning a Rabbit Pelt

Rabbits, Level 3, Activity 26

What Members Will Learn . . .

ABOUT THE PROJECT:

- How to make a tanning solution
- How to tan rabbit hides

ABOUT THEMSELVES:

- To evaluate the importance of using safety procedures

Materials Needed:

- Large, hard plastic or rubber pail with lid
- Sulfuric acid or battery acid
- Salt
- Rubber gloves
- Pelts in various stages of being tanned

ACTIVITY TIME NEEDED: 35 MINUTES

ACTIVITY

Leader Notes

In order to increase the income from the rabbit project, pelts can be tanned and either sold or made into useful items. The following lesson describes how to do this.

Use a large pail with a lid to mix the tanning solution. Either of the following recipes can be used:

A

2 gallons water
2 ounces sulfuric acid
2 ½ pounds salt

B

2 gallons water
8 ounces battery acid
2 ½ pounds salt

Mix the salt and water. Add the acid to the salt solution. (DO NOT POUR WATER INTO ACID.) Wear rubber gloves when preparing and working with this solution. Do not get acid on your skin or in your eyes.

Now prepare the pelt. Split the pelt down the belly, cut off the front legs, and remove any excess fat.

If this is a fresh pelt, put it into the tanning solution. If the pelt has been dried, soak it in water until soft before putting the pelt into the tanning solution.

Have members observe the pelts in different stages of tanning.

Leader Notes

Leave 24 hours or more.

Remove pelts and rinse in cool water. Pull flesh from the skin, working from the tail end.

Return the pelts to the solution for 48 hours or more.

Have members work pelts in the process of drying.

Remove and wash in a mild detergent solution. Rinse well and squeeze out excess water.

Let dry slowly. As the pelts dry, stretch them to break the fibers. This will cause the skin to turn white and will soften it. The more it is pulled and rubbed, the softer it will become.

Try to keep the pelt flat until drying is complete.

DIALOG FOR CRITICAL THINKING:

Q: Using acid in this lesson emphasizes the importance of safety. Safety procedures are important in all aspects of your life. Discuss safety procedures for the following: walking to and from school, riding the bus, using power tools, working in a shop, mowing the lawn, cooking. Think of other areas of your life where safety is emphasized and discuss the procedures you use.

GOING FURTHER:

1. Make a project using a tanned pelt.
2. Research potential buyers of pelts.
3. Have someone who buys pelts attend a meeting and describe what they look for when buying pelts.



Advertising Your Rabbits

Rabbits, Level 3, Activity 27

What Members Will Learn . . .

ABOUT THE PROJECT:

- The different ways to advertise your rabbits

ABOUT THEMSELVES:

- What they advertise about themselves by their actions and how they dress

Materials Needed:

- Newspaper ads
- Telephone yellow pages
- Signs
- Business cards
- Chalkboard or flip chart

ACTIVITY TIME NEEDED: 30 MINUTES

ACTIVITY

Leader Notes

It is important that the public know that you have rabbits for sale. Good advertising can mean the difference between success and failure. There are several methods to advertise.

SIGN: Put up a sign in your yard. If the road past your home isn't very heavily traveled, the sign would get better results elsewhere. Have the sign made professionally if it is to be a permanent sign.

LIST IN THE YELLOW PAGES: You can list your rabbitry in the classified directory for a relatively small amount each month.

NEWSPAPER ADVERTISING: A small classified ad that is run regularly seems to be the best. Check your local papers to see how much it costs to run an ad.

RADIO ADVERTISING: If your rabbit operation is a large one, radio advertising is a good way to go. However, you must be able to supply many customers. Most 4-H'ers will not have a large enough operation to justify radio advertising.

USE OF BULLETIN BOARDS: In every community, feed stores, grocery stores, etc., have places where you can post for sale notices. Take advantage of this free advertising.

Ask the members how they advertise their rabbits. Make a list of these on the chalkboard. The 4-H'ers may have some very unusual ways to advertise. Discuss each method listed.

Leader Notes

BUSINESS CARDS: An attractive business card is a good way to advertise.

PREPARE A SIMPLE BROCHURE: Make a simple brochure that explains what you have available to sell. These are good to pass out at fairs, shows, etc.

SHOW YOUR RABBITS: Show your rabbits at local fairs and other shows. This will get your name in the public eye. Attend swap meets.

PROMOTE RABBIT MEAT: You could set up a small booth at local events and give away samples of prepared rabbit to all who will try it.

A MOBILE STORE: A van or truck parked near a busy highway can lead to the sale of rabbits either dressed or alive.

DIALOG FOR CRITICAL THINKING:

Q: What you say and do, what you wear, and how you wear it all advertise the kind of person you are. Think carefully and discuss what each of you advertise about yourself.

GOING FURTHER:

1. Have the members check the local newspapers for ads about rabbits.
2. Have the members check the yellow pages for listing of rabbitries.
3. Design your own business card.
4. Prepare a brochure.

Have the members look at the items you have on display that advertise rabbits.



Using Rabbits in Science Fair Projects

Rabbits, Level 3, Activity 28

What Members Will Learn . . .

ABOUT THE PROJECT:

- How to conduct a science fair project

ABOUT THEMSELVES:

- To evaluate personal organizational skills

Materials Needed:

- Chalkboard or flip chart

ACTIVITY TIME NEEDED: 30 MINUTES

ACTIVITY

Leader Notes

You can expand your rabbit project by conducting science fair projects using rabbits.

Have members brainstorm about other kinds of problems and hypotheses for potential projects.

In order to conduct a science fair project, you need to attempt to solve a problem. The problem might be: Which commercial rabbit pellets will produce the most rapid gain in young rabbits?

Then you need to set up a hypothesis. Our example hypothesis might be that Family Ration will produce the most rapid gain in young rabbits. Remember that in your science fair project, you wouldn't use commercial names so each feed would be given a letter code. Family Ration might be feed A. So the proper way to state our hypothesis would be: Feed A will produce the most rapid growth in young rabbits.

Now plan your procedure, how you will conduct the experiment. In this case we will assume that we are going to use 15 New Zealand White rabbits and three different commercial feeds. The following steps should be followed:

1. Tattoo each of the rabbits so you can keep track of them. For instance, rabbits fed feed A could be tattooed 1A, 2A, 3A, 4A, and 5A. Those fed feed B and feed C could be tattooed in a similar fashion.
2. Weigh each of the rabbits and record the weight.
3. Make sure that the only difference in how the rabbits are being cared for is the feed.

Leader Notes

4. Provide the rabbits all the feed they will eat.
5. Weigh the rabbits every week; record the weight of each rabbit.
6. Examine the rabbits and record your observations each time the rabbits are weighed.
7. After six weeks, see which rabbits have gained the most. Subtract the initial weight of each rabbit from the final weight.
8. Calculate average daily gain during the experiment by dividing the number of days (42) into the net gain for each rabbit.
9. Compare results; which feed produced the most gain?
10. Write your conclusion. Feed B produced the most rapid gain in young rabbits. Feed C produced the least amount of gain.

Discuss how you can use these topics as science fair projects for rabbits.

Other science fair project ideas:

1. Rabbit's digestive system
2. A rabbit's skeleton
3. Fur genetics
 - a. Satin
 - b. Rex
4. Color genetics
 - a. Selfs
 - b. Himalayan
 - c. Chinchilla
5. Buck teeth

DIALOG FOR CRITICAL THINKING:

Q: In setting up your science fair project you will find that organization is very important. How good are your organizational skills? How organized are you at school and at home? What things do you need to work on to become more organized? How easy is it to be successful if you are not organized?



Harvesting Angora Wool

Rabbits, Level 3, Activity 29

What Members Will Learn . . .

ABOUT THE PROJECT:

- How to pluck and shear Angora rabbits

ABOUT THEMSELVES:

- To evaluate their feelings toward their animals' pain
- To examine ethical issues in animal welfare

Materials Needed:

- Plucking blade
- Scissors
- Containers for wool
- Angora rabbit

ACTIVITY TIME NEEDED: 40 MINUTES

ACTIVITY

Leader Notes

All Angora rabbits have wool that must be harvested regularly. The English and French moult about every 8 to 12 weeks. The Giant Angora does not really moult and therefore needs to have the wool harvested every 90 days.

The method you use to harvest the wool is dictated by the rabbit and the end use of the wool.

Plucking should be used on any rabbit that is going to be shown. The major disadvantage to plucking is that it can and does cause wool loss over a period of time. Another disadvantage is that it is labor intensive. Plucking should be done so that the rabbit feels no pain.

STEPS IN PLUCKING

1. Hold the animal with your left hand. Using the thumb and index finger of the right hand, or a plucking blade, begin pulling the wool.
2. Start right behind the neck and work back in an even manner.
3. Pull out as much wool as will easily come out with a firm tug.
4. Use your left hand to hold down the surrounding skin.
5. Work down the sides of the Angora as far as you can reach.

Demonstrate the plucking method.

Leader Notes

Demonstrate the shearing methods.

STEPS IN SHEARING

1. Make a part down the rabbit's back from the tail to the nape of the neck.
2. Using your scissor blade, section off a parallel piece no more than an $\frac{1}{8}$ of an inch.
3. Use your left hand to pull the wool out slightly from the body.
4. Before actually cutting, use the blunt edge of the scissor blade to "comb through" the wool section being held by the left hand.
5. It will take practice to shear the Angora so that you are getting a prime wool product.

DIALOG FOR CRITICAL THINKING:

Q: If you knew that one way of dealing with your animal caused pain but was faster than another method that did not cause pain, which one would you use? What are the ethical issues involved in this topic?

Q: Animal welfare groups are very involved in seeing that animals are not harmed. Some groups even bomb research facilities. How would you approach people like this concerning your animal operation?

GOING FURTHER:

1. Have members try to harvest the wool from an Angora rabbit.
2. Have members try to spin the wool.

ILLUSTRATIONS FOR PLUCKING AND SHEARING ANGORA WOOL

Activity Sheet

wool resting on index and middle finger, held in place by thumb

pull just tight enough to make skin taut

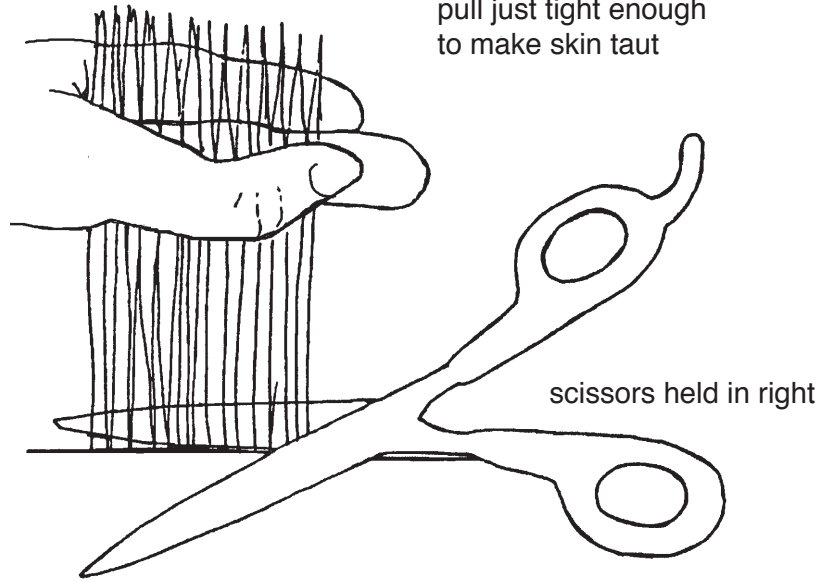

scissors held in right

scissors blades flat on skin

use blunt edge of scissors to comb second cuts and new growth out of the next section to cut

plucking blade

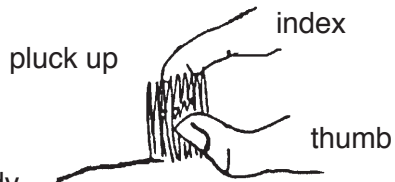

body

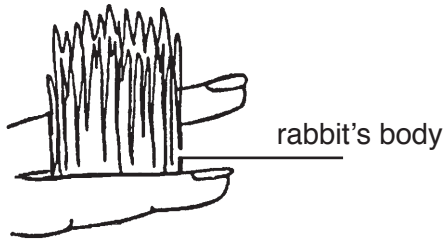

holding skin down

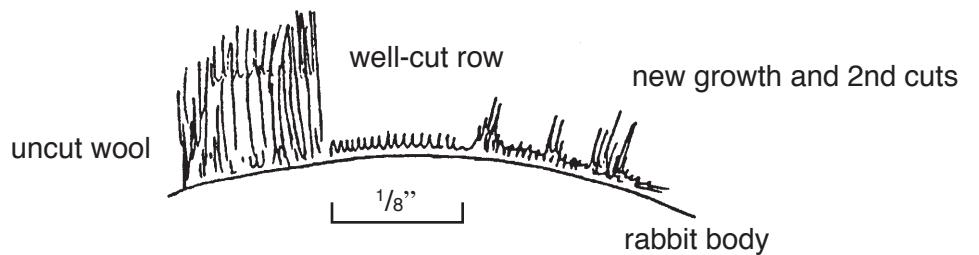

Side view of sheared sections

Leader Notes



Recycling Rabbit Manure

Rabbits, Level 3, Activity 30

What Members Will Learn . . .

ABOUT THE PROJECT:

- Ways to recycle rabbit manure

ABOUT THEMSELVES:

- To understand the importance of recycling
- Their individual responsibilities toward recycling

Materials Needed:

- Chalkboard or flip chart

ACTIVITY TIME NEEDED: 30 MINUTES

ACTIVITY

Leader Notes

Each year a doe and 40 young can produce about eight cubic feet of manure. You need to know what to do with all this manure.

Ask the 4-H'ers how they dispose of the manure produced by their rabbits. Make a list on the chalkboard or flip chart.

There are several ways that rabbit manure can be recycled. You can use rabbit manure to grow worms which can be sold for fish bait. You can sell rabbit manure for use as fertilizer in gardens. You can make a compost pile using rabbit manure and any plant materials that are available. The composted manure can be used for fertilizer.

Advantages of Using Rabbit Manure for Fertilizer

List advantages.

1. Rabbit manure has a high nitrogen content.
2. Rabbit manure will not burn lawns or plants and is easy to incorporate in the soil.
3. Rabbit manure is excellent fertilizer for gardens, lawns, shrubbery, trees, and flowering plants.

DIALOG FOR CRITICAL THINKING:

Q: Recycling rabbit manure may be economically sound but it is also a benefit to the environment. Industrialized nations need to promote reusing waste products to prevent pollution and dump site buildup. What are the ways that you can personally contribute to recycling projects? What is your responsibility toward recycling? Imagine and discuss what would happen if no one recycled. Imagine and discuss what would happen if **everyone** recycled.

Leader Notes

GOING FURTHER:

Check with local nurseries or garden centers to see what kind of a market you might have.



Making Worm Beds Out of Rabbit Manure

Rabbits, Level 3, Activity 31

What Members Will Learn . . .

ABOUT THE PROJECT:

- How to make worm beds
- The advantages and disadvantages of raising worms

ABOUT THEMSELVES:

- To evaluate all the things they do that have side benefits
- To look at what motivates them

Materials Needed:

- Galvanized washtub or large plastic container
- Rabbit manure
- Screen wire for covering the container
- Small amount of lard, meat drippings or vegetable shortening
- Piece of burlap
- One-quart watering jar
- 100 worms
- Cornmeal

ACTIVITY TIME NEEDED: 30 MINUTES

ACTIVITY

Leader Notes

If you have an open rabbitry, keeping hybrid earthworms beneath the rabbit cages will reduce odor, minimize fly problems and offer an opportunity for additional income from the sale of the worms.

Since worm beds must be kept wet and rabbits do best at lower humidity levels, the use of worms beneath cages is not recommended for enclosed rabbitries or in cold climates where the beds stay cold for many weeks.

A worm culture requires extra time and work to keep the beds turned and moist. Developing a market and providing an adequate supply requires additional effort.

If you raise rabbits in closed housing and want to raise worms, special worm pits can be built outside of the rabbitry and the manure moved to the pits. This way you can convert the manure into profit.

If you are planning to raise worms under your cages, you need to prepare the beds. You can use 1" x 12" boards to build the beds. You will need

Leader Notes

about 6 inches of manure and rotted straw or leaves to start your bed. Moisten it until you can just barely squeeze out a drop of water. Add 100 worms per doe and litter. The worms will eat the waste food and manure. Turn over the top few inches of the beds each week using a rake. The worms will keep the manure cleaned up almost daily. Therefore, there will be no odors.

Empty worm beds at least twice a year and renew them. Otherwise the beds become too acidic.

Have the members help set up a worm bed.

Another option is to raise worms in a bed outside of the rabbitry. You can use any large container.

1. Fill the container 8 inches deep with bedding material.
2. Add water until the bedding materials are moist throughout. Don't add too much water.
3. Usually you will need to add one quart of water every 2 weeks.
4. Mix 1 pound cornmeal and ½ pound of lard, meat drippings or vegetable shortening with the top 2 or 3 inches of bedding material.
5. Put 100 adult earthworms into the bed.
6. Cover the bed with damp burlap to prevent evaporation.
7. Place the screen wire over the bed. The screen wire prevents rodents from bothering the bed.
8. In order to control ants, place the container on small blocks which have been set in pans of oil.

In 4 to 6 weeks numerous small worms will be present. In six months the bedding material should be saturated with worms. A container 2 feet in diameter and 10 inches deep should produce approximately 3,500 to 5,000 fishing worms in a year.

You will need to feed the bed once after the first month and then every two weeks after that. You can use corn meal and fat or use rabbit manure.

DIALOG FOR CRITICAL THINKING:

Q: Raising worms is a fringe benefit or by-product of raising rabbits.

Many things you do have fringe benefits or by-products. For example, when you do a good job as a paperboy or a babysitter or mowing lawns for someone you are tipped accordingly. Think of all the things you do that have side benefits. How motivating are these side benefits?

GOING FURTHER:

Raise earthworms in a container as described. Keep a record of the all costs, dates of watering and feeding, pest problems, and number of worms harvested.

Adapted from a Kansas State University Cooperative Extension Service publication written by Clarence W. Linsey, Kansas State Rabbit Breeders Association, and reviewed by James P. Adams, Extension Specialist, 4-H Youth Programs, Kansas State University.

Revised for Washington State by Nancy K. Baskett, 4-H Program Assistant, Pierce County, and Jerry A. Newman, Extension 4-H Youth Development Specialist.



4-H 

WASHINGTON STATE UNIVERSITY

Copyright 2014 Washington State University

WSU Extension bulletins contain material written and produced for public distribution. Alternate formats of our educational materials are available upon request for persons with disabilities. Please contact Washington State University Extension for more information.

You may download copies of this and other publications from WSU Extension at <http://pubs.wsu.edu>. Issued by Washington State University Extension and the U.S. Department of Agriculture in furtherance of the Acts of May 8 and June 30, 1914. Extension programs and policies are consistent with federal and state laws and regulations on nondiscrimination regarding race, sex, religion, age, color, creed, and national or ethnic origin; physical, mental, or sensory disability; marital status or sexual orientation; and status as a Vietnam-era or disabled veteran. Evidence of noncompliance may be reported through your local WSU Extension office. Trade names have been used to simplify information; no endorsement is intended. Published July 2014. *This publication replaces EM4859.*

