

# Poultry Leader Guide



4-H 

WASHINGTON STATE UNIVERSITY  
EXTENSION

EM082E  
Level 2





---

# 4-H Poultry Leader Notebook

*Level II*

Identifying Poultry Feed Ingredients .....	3
How to Read Feed Tags .....	7
Boney Birds .....	11
Chicken's Digestive System .....	17
Poultry Disease Prevention .....	25
Poultry Parasites and Diseases .....	27
Cracking Up—What's in an Egg? .....	31
Making and Using an Egg Candler .....	35
Constructing a Small Incubator .....	39
Determining the Sex of Poultry .....	45
Maternal Bonding and Imprinting (Follow the Leader) .....	49
Preventing Cannibalism .....	51
The Peck Order .....	55
Economics of Broiler Production.....	59
Poultry Furniture .....	65
Types of Poultry Housing .....	69
How Birds Adapt to Their Environment .....	71

---

---

Types of Feathers and Their Functions .....	77
Feather Colors and Patterns .....	83
Talking Like a Poultry Raiser .....	87
Poultry Breed Characteristics .....	95
Pigeon Breeds and Varieties.....	99
Selecting Poultry for Show .....	105
Poultry Grooming .....	111
Poultry Showmanship .....	115
Basic Egg Cookery .....	121
Ethnic Recipes for Omelets .....	127
The Diet Balancing Act with Poultry Products.....	131
Use of Poultry Products .....	137



# Identifying Poultry Feed Ingredients

*Poultry Science, Level II*

## What Members Will Learn . . .

### ABOUT THE PROJECT

- Six nutrient classes of feed ingredients
- Feed ingredient examples of each nutrient class

### ABOUT THEMSELVES

- The nutrient classes included most in their diet
- The nutrient classes for their favorite foods

## Materials Needed:

- Broiler starter feed sample (not pelleted or crumbled)
- Broiler starter feed sample (pelleted and crumbled)
- Activity Sheet 1 - "Poultry Feed"

**ACTIVITY TIME NEEDED:** 30 MINUTES

## ACTIVITY

## Leader Notes

---

The **feed ingredients** in a poultry ration are classified into one of six nutrient classes according to their function and chemical makeup. The classes are **carbohydrates, fats, proteins, vitamins, minerals, and water**.

**Carbohydrates** are found in corn, milo, wheat, and oats. You may find any one or all of these grains in a ration. **Fats** are used to supply energy and are usually used in the form of animal fats and vegetable oils. It is hard to see fat in a ration; however, the more fat that is used the less dusty the ration will be.

**Proteins** are used for muscle development and come from soybean meal, fish meal, meat by-products, and corn gluten meal. **Vitamins** are found in alfalfa meal, yellow corn, and animal by-products. You should be able to find some of these ingredients in your ration. The best source of vitamins is a commercial vitamin premix and this will be hard to find in the ration. **Minerals** such as calcium and phosphorus are supplied by oyster shell, ground limestone, and dicalcium phosphate. You may be able to see these products in the ration. Trace minerals are found in a commercial mineral premix and cannot easily be seen in the ration.

Many commercial feeds are pelleted by a pressure and steam process. This will alter the appearance of the ration. Crumbled rations are pellets that have been broken into small pieces. Pelletting or crumbling a ration may help the bird consume a more balanced diet and reduce feed wastage.

Have two or three members examine a mixed broiler starter feed sample. Have them separate ingredients they can identify. List the ingredients and nutrient class on the "Poultry Feed" activity sheet. To see how processing can affect the structure of an ingredient, compare a ground ration to a crumbled or pelleted ration.

---

## Leader Notes

---

Have members do the “Ingredient—Nutrient Class” match on the activity sheet as a review.

### **DIALOGUE FOR CRITICAL THINKING**

1. How many different ingredients did you find?
2. How many nutrient classes did you find?
3. How easy was it to find the ingredients?
4. Discuss differences between pelleted or crumbled samples.
5. How many of the ingredients are grown in your area?
6. What nutrient classes do you include in your diet?
7. List food you eat in the proper nutrient classes.
8. What food do you eat that might be compared to pellets or crumbles?

### **GOING FURTHER**

1. Give a presentation to your class or other groups about the similarities of poultry feeds and human foods.

---

---

**IDENTIFYING POULTRY FEED INGREDIENTS**  
**POULTRY SCIENCE, LEVEL II**  
**Activity Sheet 1**

**Poultry Feeds**

List the feed ingredients and their nutrient class that you were able to identify from the feed sample provided by your leader.

Ingredients	Nutrient Class
_____	_____
_____	_____
_____	_____
_____	_____
_____	_____
_____	_____
_____	_____

Match the following ingredients by drawing a line to the correct nutrient class.

<b>Ingredients</b>	<b>Nutrient Class</b>
Phosphorus	Carbohydrates
Corn	Fats
Soybean meal	Proteins
B	Vitamins
Milo	Minerals
Alfalfa meal	Water
Wheat	
Fish meal	
Oats	
A	
Calcium	
H <sub>2</sub> O	





# How to Read Feed Tags

*Poultry Science, Level II*

## What Members Will Learn . . .

### ABOUT THE PROJECT:

- Ingredients listed on a feed tag
- To identify types of information found on a feed tag
- To identify feed tag ingredients as sources of energy, protein, mineral, or vitamin

### ABOUT THEMSELVES:

- Nutrients needed for humans are similar to those needed for poultry
- It is their responsibility to eat a balanced diet

### Materials Needed:

- Copies of Activity Sheet 2 - “Cereal Box Feed Tag Quiz” for each member
- Several examples of feed tags (you may have some of your own from purchased feed or these can be acquired from your local feed dealer)
- Pencils and paper
- Samples of some common feeds—you can ask members to bring a sample of what they feed with the tag from the bag (best if it is in a plastic bag or a jar)
- Hand out some sample feed tags
- Flip chart or chalkboard
- Several boxes of cereal for humans

**ACTIVITY TIME NEEDED:** 45 MINUTES

## ACTIVITY

Understanding the information written on the feed tag will help you identify the ingredients of the specific feed, understand the nutrient requirements of a bird, and eventually learn how to balance a ration. During our entire life we must read labels to gather information that will be helpful in our decision-making process. Poultry feed tags have some of this type of information. Thus, it is a good practice to learn to read these labels.

Proper nutrition is the key to a successful poultry flock. In the same way, if we don't get the proper nutrition by eating right, we can have health problems, our growth and development may be negatively affected, and we could die. Poultry also require proper nutrition for growth and development.

The main ingredients in poultry feeds are cereal grains (corn, wheat, bar-

## Leader Notes

Since a knowledge of feed constituents is necessary to this lesson, conduct the lesson on feed ingredients before teaching this lesson.

Review the major concepts before starting this lesson.

---

## Leader Notes

---

ley, and milo), oil meals (soybean, sunflower, and cotton seed), fish meal, packing house by-products, and dried milk products. These ingredients are high in energy, low in fiber, and are highly digestible.

Regardless of feed type, all feeds include six basic nutrients: protein, carbohydrates, fats, minerals, vitamins, and water. Knowing what combination of these nutrients your feed supplies is critical to a good feeding program.

**Protein** supplies the materials necessary to make body tissues. They are the building blocks of which chickens are made. Protein makes up muscle, internal organs, bones, and the blood. They also make up the skin and feathers of birds. If you feed more protein to your chickens than they need, the extra protein is used as energy for body functions such as heating or cooling the body, or producing eggs. Grains such as corn, wheat, and milo supply part of the protein needed for growth. Protein supplements such as soybean meal are used to balance the ration.

**Carbohydrates** and **fats** supply energy. These nutrients are to poultry what gasoline is to a car. They provide energy for movement: walking, breathing, heartbeat, and so on. These nutrients also help the bird produce heat to keep warm. Energy fed in excess of a bird's requirements is stored as fat until the body needs it.

**Minerals** build bones and support other life functions. Calcium and phosphorous make up the largest percentage of the minerals needed by a bird. Minerals that are needed in only very small amounts are called *trace minerals*. Calcium and phosphorus are usually added to the ration for growth of bones and egg shell formation. Many producers use calcium carbonate, bone meal, oyster shells, or dicalcium phosphate as feed additives to supply these necessary minerals. Sodium, chlorine, and iodine are also critical minerals that are usually added in the form of iodized salt. Trace mineralized salt also has a number of the minor minerals needed for proper nutrition.

**Vitamins** are just as important as other feed nutrients, but they are needed in smaller amounts. Vitamin A is required for the health of eye, nasal passages, and lungs. For strong bones and healthy blood, vitamin D is needed. Vitamins are also required for other body functions. The bird's body produces some vitamins while others must be added to the ration or absorbed from sunlight (like vitamin D3).

**Water** is the most important part of the bird's diet. It is the cheapest part of the diet, but it is often the most neglected part. A bird's body is over two-thirds water and blood is over 90 percent water. Water is also necessary in digestion and for carrying food nutrients to the rest of the body. Water carries away waste products through the urine, functions as the body's built-in cooling system, and lubricates the joints. Your bird can live longer without feed than without water.

In addition to the six nutrients, most rations also contain **feed additives**. These additives are primarily put in the feed to prevent or control diseases and parasites. The addition of additives to feed is regulated by the Food and Drug Administration.

Most states require that a feed tag be attached to each bag of feed. This tag usually contains the following minimum information: net weight; guaranteed analysis for crude protein, crude fat, and crude fiber; a list of the ingredients; any active ingredients, such as drugs, and their function in the feed; instructions on feeding; and any warnings, such as to discontinue use five days before slaughter.

Have you ever thought about what goes into prepared poultry feeds? Let's look at these samples of feed and the tag from each feed. The tag is an important tool—it tells us what is in the feed. When you study the samples, answer these questions:

- What kind of poultry is this feed meant for?
- What are some of the major ingredients in the feed?
- What are the sources of protein, energy, vitamins, and minerals in this feed?
- Why are some feeds medicated?
- What does a “guaranteed analysis” mean?

### DIALOGUE FOR CRITICAL THINKING

1. If you have feed tags (labels) from different companies, how do they differ and how are they alike?
2. Why are some grains not listed by name on the feed tag?
3. Can you tell from the feed tag if the feed contains the necessary nutrients?
4. Why is it important that labels (tags) carry the contents of a package?
5. Why should you read the labels of the foods you purchase?
6. How can labels help you make wise food purchases in the supermarket?
7. If your diet was restricted from using an ingredient such as salt or sodium, how would labels be useful to you?

### GOING FURTHER

1. Arrange a trip to a local feed mill to see how the feed ingredients are weighed and mixed together to make the complete ration.
2. Have the 4-H'ers collect samples of different ingredients that are found in a ration and find out as much as possible about the preparation of these ingredients before they are put into the ration.
3. Divide the group into teams and have each team compare two feed tags from different species or different age groups within the same species. Have them identify what kind of feed it is.
4. Have 4-H'ers make lists of essential nutrients found on the feed tag.
5. Compare the ingredients in the ration with the ingredients or nutrients found in some of our human rations such as breakfast cereals.

Arrange the feed samples on a table so that all the 4-H'ers can gather around it, or divide the group into pairs and give each pair a feed sample and feed tag. This approach of providing a situation and asking your members to come up with answers or a solution is an effective way to teach this kind of material. After you have given the groups time to work on their questions, bring them together and let them tell the rest of the members what they have learned. Let them do the talking and ask questions but don't give the answers. Once all groups have had an opportunity to give their explanations, use a different feed tag to help them understand how to read the information that is included. Be sure to refer to some of the good points each group made and also be sure to correct some inaccuracies that they might have made.

Provide cereal boxes, the question sheet, and pencils. Then briefly examine the cereal box labels together. Look for the requested information and when everyone is done, compare the cereals represented for nutritional value. Repeat this activity with a feed tag from animal feed and compare with cereal box exercise.

---

---

## HOW TO READ FEED TAGS

### POULTRY SCIENCE, LEVEL II

#### Activity Sheet 2

#### Cereal Box/Feed Tag Quiz

Cereals are required to include nutrition information on the box. The label includes a list of ingredients which are listed in order from most to least. It also lists percentages of recommended daily allowance and amounts of some nutrients per serving.

1. Name of cereal
2. Main ingredient
3. Serving size \_\_\_\_\_ servings per package \_\_\_\_\_
4. What does U.S. RDA mean?
5. Which vitamins are listed?
6. Does this cereal provide all of your daily need (100%) for any of the nutrients? If so, which?
7. Which nutrients increase when milk is added?
8. Which nutrients are minerals?
9. Do the ingredients include BHA or BHT? If so, why?
10. Repeat this exercise using a poultry feed tag. Compare and discuss the answers.



# Boney Birds

*Poultry Science, Level II*

## What Members Will Learn . . .

### ABOUT THE PROJECT:

- The major parts of a bird's skeleton
- The function of three to five major skeletal parts
- How a bird's skeleton is adapted for flight

### ABOUT THEMSELVES:

- Boney parts that birds and humans have in common
- How knowledge of birds helped develop airplanes

### Materials Needed:

- Large sheet of paper
- Marking pens
- Activity Sheet 3 - "Bird Skeleton"
- Leader Key - "Bird Skeleton"

**ACTIVITY TIME NEEDED:** 45 MINUTES

## ACTIVITY

What are some observations that you can make when you see a chicken or other type of bird? What are some similarities that you see between birds and humans? What are some differences?

Poultry are **bipeds**. That means that they stand and walk on two legs just as humans do. What other animals walk on two legs? If we look at the skeleton of a bird we would see that it is similar to that of most mammals (with a few exceptions). The first difference is that a bird has a pair of extra bones in the shoulder area called the **caracoids**. These bones allow the wings to move and provide additional support for the wings. The second difference is in the spine. The neck bones, or cervical vertebrae, which connect the body to the head are formed in an S-shape. This S-shape acts as a spring when a bird lands on the ground and provides a cushion to the head. The third difference between the skeletal structure of birds and mammals is that the back vertebrae are very strong because they are fused together providing a firm support for the wings.

The skeletal system is closely connected to the respiratory system. Many of the bird's bones are hollow and are connected to the respiratory system, and serve as a reservoir for air. This makes the bird lightweight for flight. These hollow bones are called **pneumatic** bones. Pneumatic bones in the bird include the skull, humerus, keel, clavicle, and lumbar and

## Leader Notes

Write down their answers on a chalkboard or large sheet of paper. Have members discuss structural similarities and differences between poultry and humans.

List and discuss three main skeletal differences of birds as compared to humans.

---

## Leader Notes

---

scapular vertebrae. If necessary, a bird could breathe through an open bone if its air supply was cut off to its trachea, or windpipe.

Other functions of the skeleton include attachment of muscles, protection of the vital organs, and a source of red blood cells. Egg-laying hens also have **medullary** bones. The marrow cavity of these bones, which include the femur, tibia, sternum, ribs, and scapula, contain the honeycomb lac- ing of bone spicules or tiny spikes that provide a source of calcium which the hen uses to calcify shells. This type of bone is usually absent in males or nonlaying females.

The **mandible** and **incisive** bones make up the beak of the chicken and turkey or the bill in waterfowl. The shape of the beak or bill is influenced by the bird's natural diet. Chickens and turkeys have a long, pointed beak which allows them to obtain their natural diet of seeds and insects. The wing of a bird consists of the **humerus, radius, ulna, metacarpus, and phalanges** bones. The phalanges and metacarpus bones are similar to the fingers and wrist bones in humans. The **clavicle** is the well-known wish bone. The **sternum** or breast bone is the largest bone in the fowl. Waterfowl have a much larger and flatter sternum than chickens and turkeys, as it provides protection to the vital organs when waterfowl land on water. The **vertebrae** from the base of the neck to the base of the tail are fused with the **ilium** and **ischium** to provide rigidity to the skeleton for flight. Because the egg passes between the two pubic bones which are located below the vent of the bird, the distance between them is used as an indicator of egg production. The **femur, fibula, tibia, and metatarsus** bones make up the leg of the bird. The metatarsus bones are comparable to the ankle bones in humans. Most breeds or varieties of chickens and turkeys have four toes, a few have five. The shape and structure of the feet and toes of birds depends on their natural diet. For example, grain eaters, such as chickens and turkeys, have long sharp toes for scratching the soil for seeds and insects. Waterfowl, such as ducks and geese, have webbed feet for paddling in the water. Most species of birds have seven pair of ribs. The ribs are flexible because they expand and contract as the bird breathes.

Hand out "Bird Skeleton" Activity Sheet.  
List similarities of bird and human skel-  
etons on a chalkboard or newsprint.

Let's take a look at the bird's skeleton and see how many parts we can identify. How many bones do you think are the same as yours?

### DIALOGUE FOR CRITICAL THINKING

1. What are pneumatic bones and what do they do?
2. What are medullary bones? Name some.
3. What mineral is most important to an egg-laying bird?
4. How is a bird's skeleton adapted for landing purposes?
5. What is a biped?
6. How does the skeletal structure of birds differ from that of mammals?
7. What bird characteristics do you think were important in developing airplanes?
8. Do you know or can you list how people use bird bones?

### **GOING FURTHER**

1. Make a poster of a bird's skeleton and give a talk at your next 4-H club, project meeting, or in your class at school.
2. Save the bones from a chicken your family ate and identify them.

---

---

**BONEY BIRDS**  
**POULTRY SCIENCE, LEVEL II**  
**Activity Sheet 3**

**Bird Skeleton**

Draw a line from the name of the bone to the correct place on the diagram.

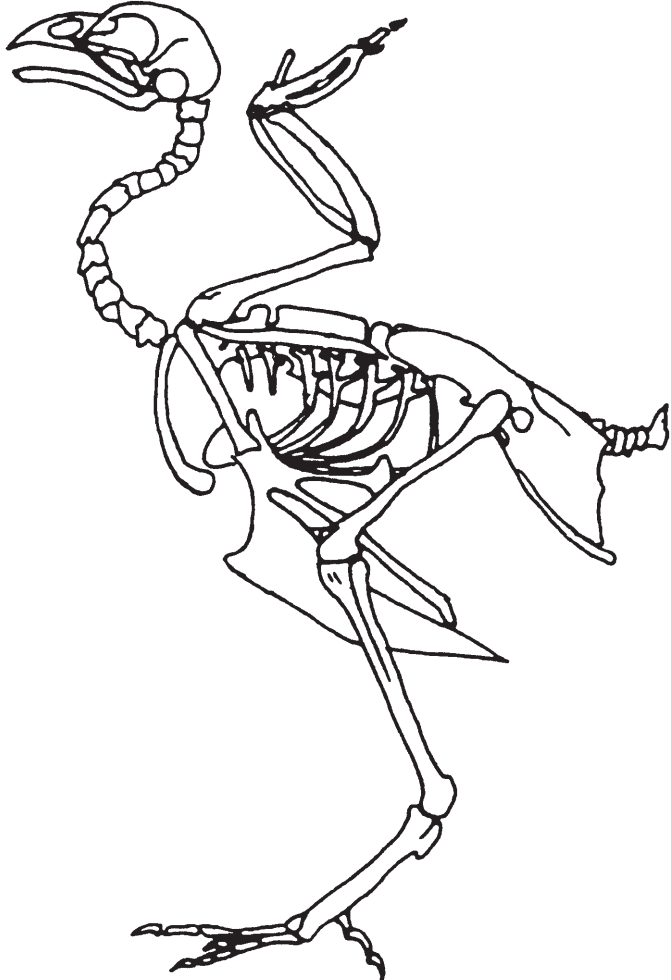

skull

sternum

coracoid

clavicle

cervical vertebrae

mandible

incisive

rib

pubic bone

phalanges

metacarpus

ulna

radius

humerus

scapula

ilium

tail bone

metatarsus

tibia

femur

---

---

**BONEY BIRDS**  
**POULTRY SCIENCE, LEVEL II**  
**Leader Key**

**Bird Skeleton**

Draw a line from the name of the bone to the correct place on the diagram.

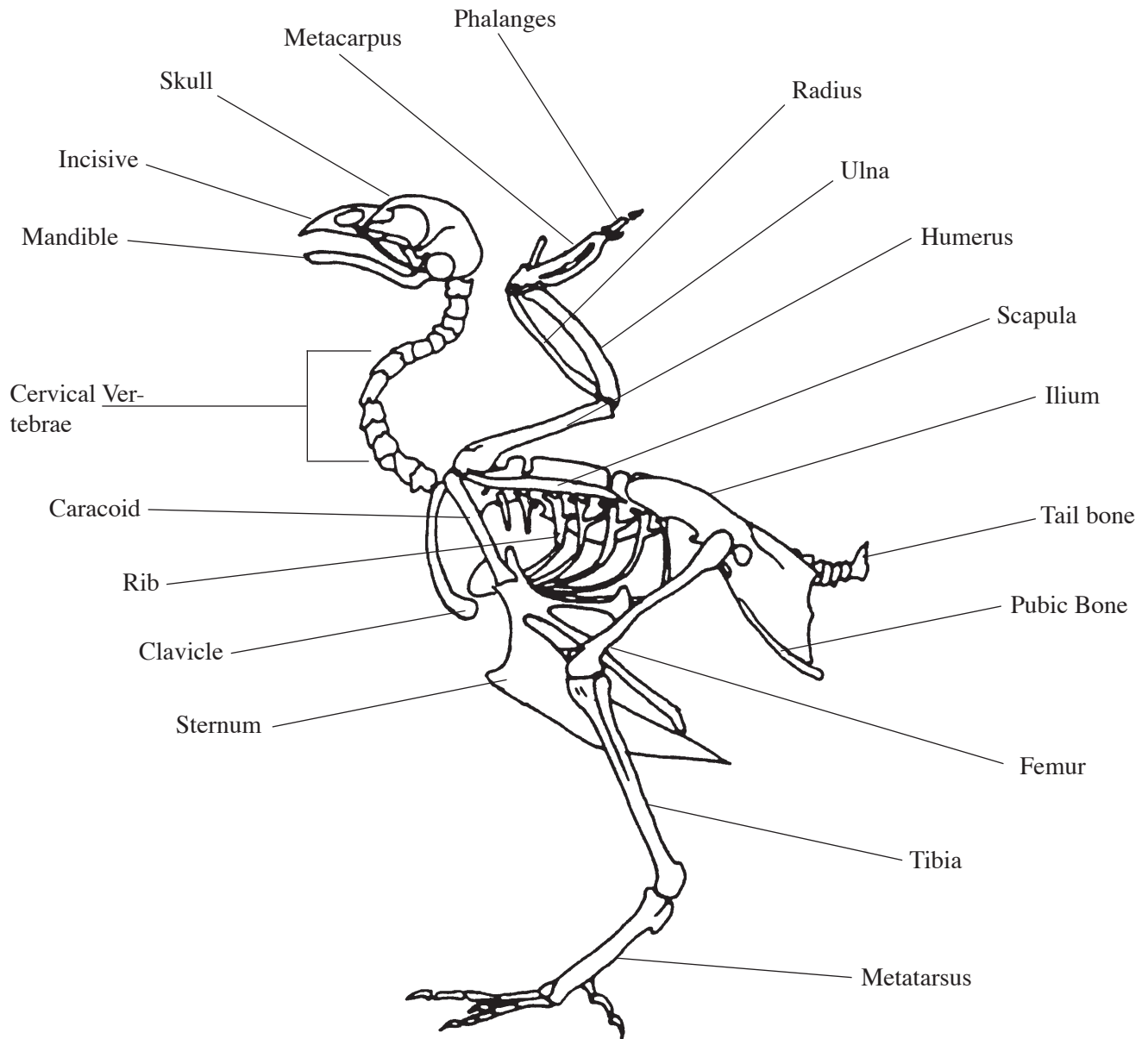





# Chicken's Digestive System

*Poultry Science, Level II*

## What Members Will Learn . . .

### ABOUT THE PROJECT:

- The four functions of a chicken's digestive system
- To identify at least eight parts of the chicken's digestive system
- The eight functions of each major part of the digestive tract

### ABOUT THEMSELVES:

- How a bird's digestive system is similar to that of a human's
- Digestive tract parts they have that function as a chicken's
- How the food they eat is processed to provide nutrients their body needs

### Materials Needed:

- Chalkboard or newsprint
- Markers
- Activity Sheet 4 - "Digestive Tract"
- Leader Key - "Digestive Tract"
- Activity Sheet 5 - "Digestive System Word Search"
- Leader Key - "Digestive System Word Search"

**ACTIVITY TIME NEEDED:** 45 MINUTES

## ACTIVITY

## Leader Notes

---

The **digestive system** consists of the parts of the body that help chew and digest feed. This system is also responsible for moving the digested food particles through the chicken's body and absorbing the products of digestion. Chickens have certain special organs that are not found in other animals.

Functions of the chicken's digestive system are to get the food into its mouth with its beak or bill (**prehension**), storage of the food (in the crop) until it can be digested, physical breaking down of the food particles by the gizzard (**mastication**), chemical breaking down of the food nutrients into the simple forms (**digestion**), passage of the simple forms across the intestinal wall to the blood vessels (**absorption**), and storage and elimination of the wastes.

The structure and length of the digestive tract of an organism is determined by what type of food that it eats. Meat and grain eaters (**omnivores**), such as birds, dogs, cats, and humans have shorter digestive tracts than cattle or sheep which are **herbivores**, animals that eat complex

List functions and other terms on chalkboard or newsprint. See if members can define or explain the terms by working in small groups before discussing them in general.

---

## Leader Notes

---

Hand out Member Activity Sheet - "Chicken Digestive Tract." See how many parts members can label in pencil. Then, as you use the text to discuss the parts, let members correct their sheets, or take up sheets and give back after discussion as a post-test.

plant materials. For example, the length of the bird's digestive tract is approximately 4 times longer than its body. The digestive tract of a sheep measures approximately 27 times its body length. The longer tract is necessary to allow a longer time for digestion to take place.

A chicken, like a human, is a **monogastric**, which means it has a simple stomach. Cattle and sheep are **polygastric**, or ruminants, because they have four stomachs.

The major parts of a chicken's digestive system and their functions are:

1. **Mouth** - The seizing or grasping of food by birds differs from mammals because birds do not have teeth, lips, or cheeks. The shape of the bird's beak or bill is related to the type of food it eats (for example chickens and turkeys have pointed beaks because they are grain eaters.) A chicken's tongue is pointed with barb-like projections on the back and hard projections on the roof of the mouth which serve to force the food toward the gullet (or esophagus) of the bird.
2. **Gullet (or esophagus)** - the gullet is a flexible tube, next to the windpipe, that connects the mouth to the crop (like a human's throat).
3. **Crop** - This is the first storage site for feed eaten. The crop stores and softens the food. The time food spends in the crop depends on the type of food and how much food is in the gizzard. Whole grain is kept in the crop longer than ground grain.
4. **Glandular Stomach** - The glandular stomach or proventriculus contains cells that secrete, or give out, digestive juices that start the chemical breakdown of food particles.
5. **Gizzard** - The gizzard serves as the bird's teeth to grind the food. It is composed of a thick, powerful muscle and is lined with a thick, tough lining. Birds eat small rocks or pebbles called grit that they use to grind the food.
6. **Small Intestine** - The small intestine is a section which extends from the gizzard to the junction with two blind pouches, called the **ceca**. The first section is the duodenal loop that surrounds the **pancreas**. The pancreas secretes insulin which regulates how the body uses sugar. It also secretes pancreatic juice which aids in the digestion of fat, starches, and protein. The main functions of the small intestine are secretion of digestive juices and absorption of nutrients.
7. **Ceca** - The two ceca, sometimes called blind guts, mark the junction of the small and large intestines. Even though a chicken can live without its ceca, some digestion takes place here. The ceca is a favorite site for

multiplication of parasites such as cecal worms and protozoa, like the blackhead organism.

8. **Large Intestine** - The large intestine is very short in birds and its major functions are to reabsorb water and store waste materials.

9. **Cloaca** - The cloaca is an enlarged part found where the large intestine joins the vent. Feces from the large intestine are passed out of the body through the vent. This is a common passageway for the ends of both the reproductive and digestive tracts.

10. **Liver** - The liver is an accessory organ to the digestive tract because it secretes bile, filters the blood, and stores excess carbohydrates. The green colored **gall bladder** is embedded in the liver tissue. (The chicken has a gall bladder, but some other birds do not.) The liver has two bile ducts which carry the bile from the liver to the intestines. The right duct is enlarged to form the gall bladder, through which most of the bile passes and is temporarily stored. The **spleen** is a dark red organ next to the liver. Its main function is the destruction of red blood cells. The excretion of water and metabolic waste occurs largely through the kidneys. These wastes are filtered out as blood passes through the **kidneys**. The wastes are excreted as a whitish pasty substance that gives bird droppings their characteristic white color.

Use the "Digestive System Word Search" as a final review of terms.

### DIALOGUE FOR CRITICAL THINKING

1. What new terms did you learn from this lesson?
2. Is your digestive system more comparable to that of a sheep or a chicken?  
(The chicken, like the human, is a monogastric animal which means the presence of a simple stomach. In contrast, sheep are called polygastric or ruminant animals because they have four stomachs.)
3. What are some of the main differences between chicken and human digestive systems?
4. How does the food that chickens eat compare with the food that you eat?  
(Chickens eat grains and humans consume grains in the forms of breads and cereals; chickens eat soybeans and humans eat soya flour, roasted beans, and soybean oil; chickens eat fishmeal and humans eat fish. Although chickens eat the same types of feed as humans, most of the food for chickens is inedible [not fit for human consumption].)
5. Why is it important for you to chew your food well before swallowing and not for a chicken?
6. Could a chicken get along without grit for its gizzard?  
(Yes, particularly chickens that are fed ground feed. Most egg-type chickens and broilers which are fed ground feed are not fed grit.)

### GOING FURTHER

1. Make a poster of the digestive system of a chicken and prepare a talk to present to your next 4-H club meeting or your school classroom.
2. Visit a feed store and compare the composition of poultry feed with livestock feed fed to cattle and sheep.
3. Help process a fryer and identify the digestive tract parts. Observe or take notes about the contents of each part and how it changes as digestion occurs.

**THE CHICKEN'S DIGESTIVE SYSTEM**  
**POULTRY SCIENCE, LEVEL II**  
**Activity Sheet 4**

**Digestive Tract**

Match name with number.

- \_\_\_ Beak and mouth
- \_\_\_ Ceca
- \_\_\_ Cloaca
- \_\_\_ Crop
- \_\_\_ Duodenal loop
- \_\_\_ Gall bladder
- \_\_\_ Gizzard
- \_\_\_ Glandular stomach
- \_\_\_ Gullet
- \_\_\_ Kidney
- \_\_\_ Large intestine
- \_\_\_ Liver
- \_\_\_ Pancreas
- \_\_\_ Small intestine
- \_\_\_ Spleen
- \_\_\_ Ureter

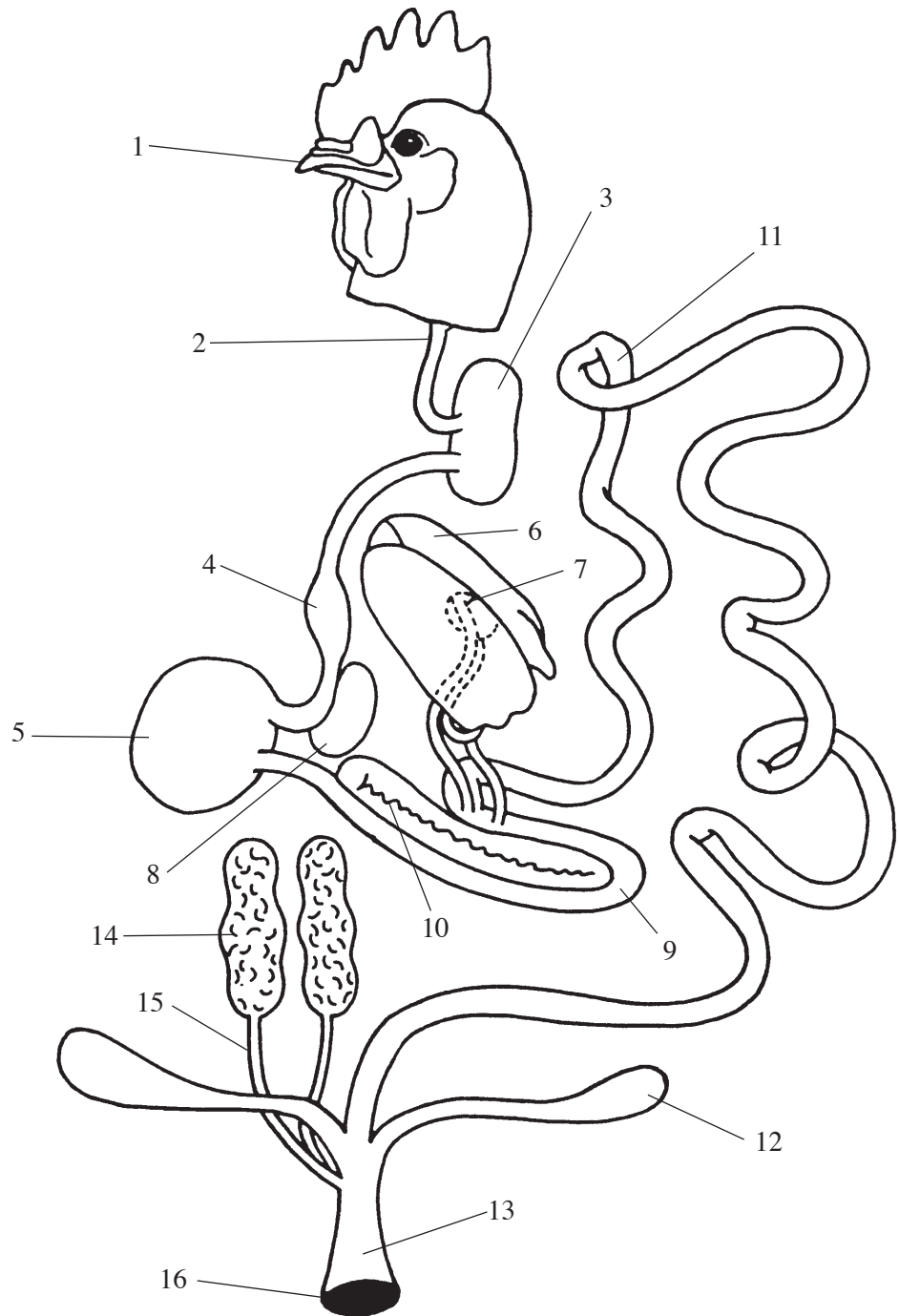

---

---

# THE CHICKENS DIGESTIVE SYSTEM

## POULTRY SCIENCE, LEVEL II

### Leader Key

#### Digestive Tract

Match name and number.

1. Beak and mouth
2. Gullet
3. Crop
4. Glandular stomach
5. Gizzard
6. Liver
7. Gall bladder
8. Spleen
9. Duodenal loop
10. Pancreas
11. Small intestine
12. Ceca
13. Large intestine
14. Kidney
15. Ureter
16. Cloaca

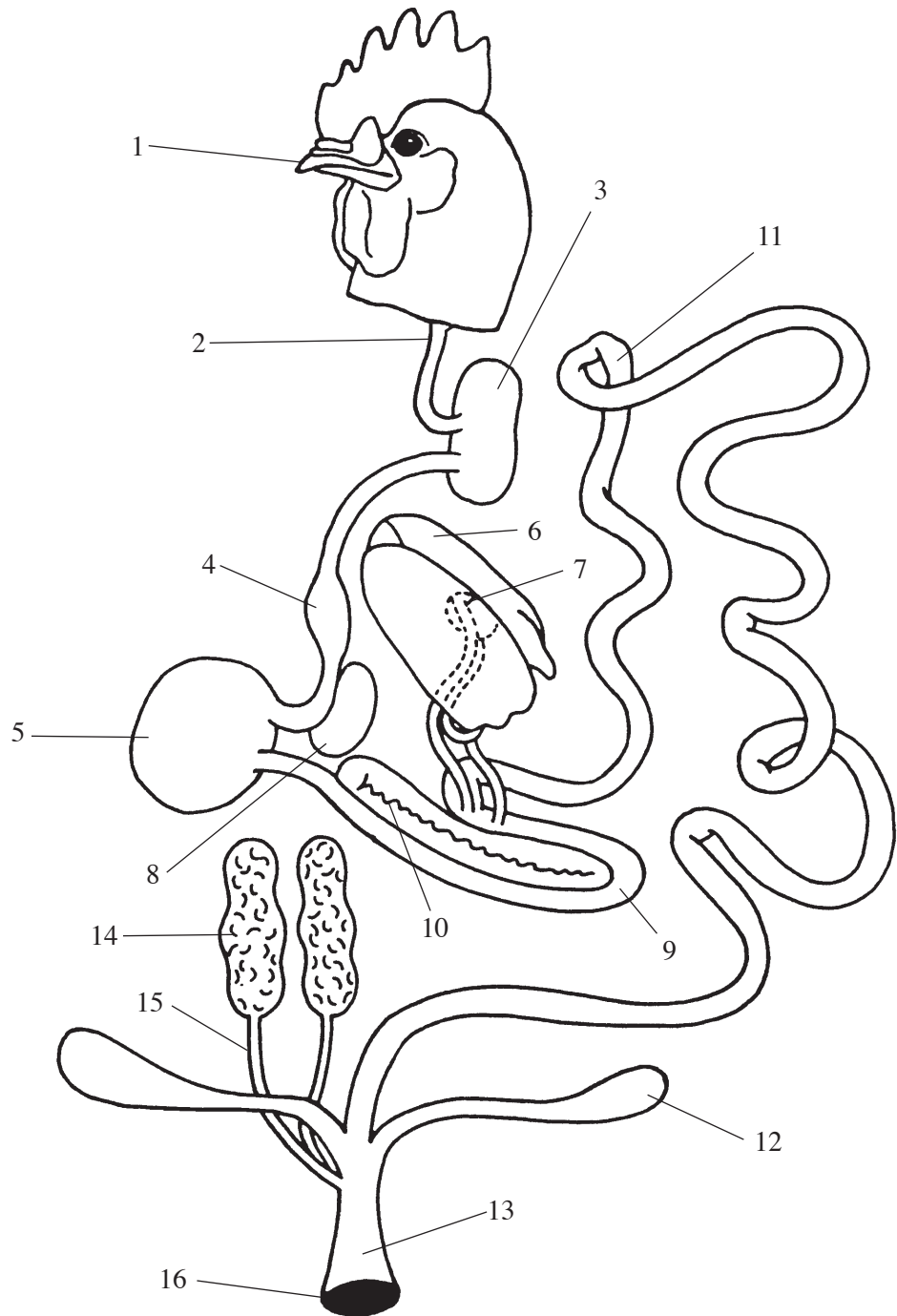

---



---

**THE CHICKEN'S DIGESTIVE SYSTEM**  
**POULTRY SCIENCE, LEVEL II**  
**Activity Sheet 5**

**Chicken Digestive System**

Word Search

Find the hidden words in the puzzle.

prehension	O	M	N	I	V	O	R	E	J	D	N	O	O
digestion	S	O	Q	T	U	A	E	I	T	I	H	O	L
monogastric	Z	N	P	T	S	S	E	U	U	G	E	M	G
ceca	X	O	A	E	U	M	U	T	T	E	E	N	A
small intestine	G	G	I	Z	Z	A	R	D	D	S	I	A	L
gizzard	L	A	T	A	Y	L	A	E	I	T	T	J	L
crop	B	S	B	I	L	L	L	G	R	I	T	T	B
grit	P	T	A	O	U	I	R	Y	O	O	S	T	L
omnivore	P	R	E	H	E	N	S	I	O	N	S	S	A
liver	I	I	S	E	U	T	K	S	U	S	M	U	D
bile	A	C	E	C	A	E	S	L	A	E	I	O	D
gall bladder	H	H	H	R	K	S	H	I	M	B	I	L	E
	O	P	P	O	P	T	M	V	A	E	O	U	R
	M	E	M	P	A	I	E	E	Q	R	S	T	U
	G	O	F	I	G	N	S	R	U	M	N	O	P
	Q	S	C	W	D	E	V	R	G	N	T	H	M

---

---

# THE CHICKEN'S DIGESTIVE SYSTEM

## POULTRY SCIENCE, LEVEL II

### Leader Key

#### Chicken Digestive System

Word Search

Find the hidden words in the puzzle.

prehension	O	M	N	I	V	O	R	E	J	D	N	O	O
digestion	S	O	Q	T	U	A	E	I	T	I	H	O	L
monogastric	Z	N	P	T	S	S	E	U	U	G	E	M	G
ceca	X	O	A	E	U	M	U	T	T	E	E	N	A
small intestine	G	G	I	Z	Z	A	R	D	D	S	I	A	L
gizzard	L	A	T	A	Y	L	A	E	I	T	T	J	L
crop	B	S	B	I	L	L	L	G	R	I	T	T	B
grit	P	T	A	O	U	I	R	Y	O	O	S	T	L
omnivore	P	R	E	H	E	N	S	I	O	N	S	S	A
liver	I	I	S	E	U	T	K	S	U	S	M	U	D
bile	A	C	E	C	A	E	S	L	A	E	I	O	D
gall bladder	H	H	H	R	K	S	H	I	M	B	I	L	E
	O	P	P	O	P	T	M	V	A	E	O	U	R
	M	E	M	P	A	I	E	E	Q	R	S	T	U
	G	O	F	I	G	N	S	R	U	M	N	O	P
	Q	S	C	W	D	E	V	R	G	N	T	H	M



# Poultry Disease Prevention

*Poultry Science, Level II*

## What Members Will Learn . . .

### ABOUT THE PROJECT

- Five major areas of a good disease prevention program
- Most common poultry disease to prevent

### ABOUT THEMSELVES:

- Importance of a human disease prevention program
- Three ways to prevent basic human diseases

### Materials Needed:

- Pencil and paper
- Flip chart and markers

**ACTIVITY TIME NEEDED:** 45 MINUTES

## ACTIVITY

## Leader Notes

---

Disease prevention in poultry production is much more economical and effective than treating diseases with medications. Although medication may relieve the problem, much of the damage is already done, such as retarded growth, reduced egg or meat quality, and increased costs of production. However, with some simple planning steps most diseases can be prevented.

### Housing

First, plan the housing of the birds to provide good ventilation and adequate heat, feeder, and waterer space. Avoid overcrowding. It is a major source of stress and disease in a flock. Keep different species in separate housing. If possible, also raise the age groups separately. Make sure the buildings or pens have good drainage, as excess moisture results in many disease problems. Construct the buildings or pens to be impenetrable to predators and wild birds.

### Nutrition

It is best to use commercially available poultry feeds appropriate for the species, age, and usage of the flock. Store feed in cool, dry, rodent-proof containers.

### Sanitation

Practice good common-sense practices, such as daily cleaning of drinkers, removal of litter wet spots, and frequent removal of manure.

---

## Leader Notes

---

Have the members discuss each of these topics in relation to disease prevention in small groups. As each group reports back, list major items on flip chart.

### **Daily Bird Care**

Examine birds daily and weigh some individuals weekly. Remove sick or dead birds daily. Place sick birds in a pen far removed from the rest of the flock. Cull abnormal or lame birds.

### **Buying Birds**

Buy new stock from a hatchery or breeding source that is a participant of the National Poultry Improvement Plan. This will assure that the birds will be free from several of the egg-transmitted diseases such as salmonella pullorum and the mycoplasmas. Have a quarantine pen available for any new arrivals and keep them there for three weeks before introducing them to the rest of the flock.

### **Traffic Control**

People are the main spreaders of diseases to and from poultry flocks. Screen all visitors before they contact the birds. Ask that they not come into contact with other birds on the day of the visit. Give them boots to wear before entering the poultry pens.

### **Vaccination**

Unless you have specific disease problems, it is best not to use vaccines. Most farms have coccidiosis. Therefore preventative medication is necessary in the feed.

### **Medication**

Before using medication, be sure you have a diagnosis of the problem by your veterinarian. Always follow label instructions exactly.

Using the items the group has outlined, have each group design a preventative health program listing daily, weekly, and occasional activities for flock care.

## **DIALOGUE FOR CRITICAL THINKING**

1. What was the most common disease prevention activity mentioned?
2. What was the most difficult to understand? Why?
3. What major health problems were discussed?
4. What are some common human disease preventions? How are they used?
5. How important do you feel human disease prevention is?
6. Name some diseases that were once common, but now are rare due to effective disease prevention programs.

## **GOING FURTHER**

1. Design a disease prevention program for your family.
2. Give a presentation to civic groups about your poultry disease prevention program or the importance of a community disease prevention program.



# Poultry Parasites and Diseases

*Poultry Science, Level II*

## What Members Will Learn . . .

### ABOUT THE PROJECT:

- Five common causes of poultry disease
- Three types of parasites

### ABOUT THEMSELVES:

- The importance of personal hygiene
- Possible human parasites
- Their feelings about social parasites

## Materials Needed:

- Chalkboard or flip chart

**ACTIVITY TIME NEEDED:** 30 MINUTES

## ACTIVITY

## Leader Notes

---

Poultry can become ill from a number of diseases. These diseases are frequently classified according to their cause. Diseases can be caused by viruses, bacteria, parasites such as mites or worms, poor nutrition, or toxic substances. The most common of these diseases will be discussed.

### Parasites that live on skin and feathers

Mites and lice frequently live on the skin of poultry. **Lice** are true insects, while **mites** are related to spiders. Mites and lice are irritating to the birds, and frequently spread diseases among the flock. A flock may become infected through contact with other poultry or wild birds.

Diagnosing lice or mite infection involves careful inspection of each bird's feathers and skin. Mites frequently like to congregate under the bird's tail. Lice can be anywhere on the skin. Lice will place masses of eggs at the base of the feathers. Some mites feed only at night, then leave the bird during the day, so check the coop at night with a flashlight.

Treatment of these external parasites involves spraying or dusting with an insecticide. Treatment of the birds with flea powders approved for cats is safe and effective. Application of sprays or powders must be repeated at least two or three times, 10 days apart to eliminate the parasites. From then on, the birds should be inspected regularly, at least every two weeks for reoccurrence of these pests.

List each parasite or disease on chalkboard or flip chart as it is discussed. Ask members to give ideas first. Describe symptoms or show a bird with symptoms and ask members to suggest treatments.

### Internal parasites

Poultry are frequently infected with a tiny, single-celled organism called

---

## Leader Notes

---

**coccidiosis.** These parasites live in the intestinal tract of birds, where they can cause much damage. Infected birds excrete the eggs of this parasite (called oocysts) in their droppings.

Other birds become infected when they eat the eggs while feeding on the ground.

Signs of coccidiosis include diarrhea, which is often blood-tinged. The sick birds begin to act cold, huddle together, and fluff their feathers.

Diagnosis is achieved by identifying the parasite eggs in the droppings under a microscope.

Coccidiosis medication is given in the drinking water or the feed to stop the disease. Prevention of coccidiosis is primarily by keeping conditions in the poultry house dry and manure free.

### **Nutritional Diseases**

Nutritional diseases are common in small poultry flocks. Although most commercially available feeds are nutritionally balanced, each type of feed is specifically designed for a given species of poultry for a specific purpose. For instance, starter rations are designed for baby chicks while lay rations are formulated for birds in egg production. It is very important to adhere to the diet formulated for the species and age group.

Sometimes even birds on commercial rations may suffer from a deficiency of a nutrient if the feed has been mishandled, i.e., allowed to get wet or improperly stored. Commercial feeds occasionally get diluted with added grain. This results in malnutrition, obesity, and poor production. To prevent malnutrition, scraps, grain, and foraging should not constitute more than 10 percent of the poultry diet.

Typical signs of malnutrition may include:

- poor, dull feathering and scaly skin;
- soft and curved leg and keel bones;
- high percentage of runts and poor-doers;
- poor egg production, soft shelled eggs;
- poor egg fertility and hatchability.

### **DIALOGUE FOR CRITICAL THINKING**

1. List several causes of poultry diseases.
2. Name three types of parasites.
3. What poultry diseases have you experienced? Why?
4. How important is personal hygiene?
5. How do you and your friends act toward students who do not practice good personal hygiene?
6. Has your school ever experienced an outbreak of lice or other parasite? How was the problem handled?

7. People who use other people for personal gain could be referred to as a parasite; for example, those who copy others' homework, bum rides but never offer them, or hang around one friend because he or she is popular. How are these people like parasites? How do you feel about these people? Think of solutions to this problem.

### **GOING FURTHER**

1. Visit a veterinarian to see parasite samples.
2. Check for parasites in your flock.
3. Check feed tags at a feed store to see what medications are added for parasite or disease control.





# Cracking Up—What’s in an Egg?

*Poultry Science, Level II*

## What Members Will Learn . . .

### ABOUT THE PROJECT:

- The major parts of an egg
- The functions of the parts of an egg
- How an egg loses quality

### ABOUT THEMSELVES:

- Their feelings about learning by doing
- How the beginning of their life from an egg compares to that of a chick beginning from an egg

## Materials Needed:

- Several fresh eggs (both brown and white, if possible)
- Clear glass plate
- Hot tap water
- Large clear water glass or fruit jar
- Sharp knife
- Handout 1 - “Parts of an Egg”

**ACTIVITY TIME NEEDED:** 45 MINUTES

## ACTIVITY

## Leader Notes

---

The egg is one of nature’s most complete foods. The reason for this high nutritional value is that the developing chick’s only source of food during its stay inside the egg are the nutrients present in the egg. This explains the perfect balance of the six nutrients essential for growth.

The egg is made up of many complex parts. An understanding of these parts, how they are formed, and their functions is very helpful if you plan to conduct experiments on incubation, embryonic development, and brooding, or want to learn about how to determine the quality of the eggs that you buy.

### The Shell

Looking at the egg from the outside, we first see that the shell, which is a hard protective covering, is composed primarily of calcium carbonate. Its function is to provide protection to the egg contents and to provide certain minerals to the developing embryo. The shell is very porous. A normal egg shell has 6,000 to 8,000 pores (holes) throughout the shell. These pores permit the transfer of oxygen, carbon dioxide, and water in and out of the shell for the developing embryo. Shell color is a genetic trait. The White Leghorn, the most popular egg-type chicken in

Give each member a fresh egg and have each describe the appearance of the outer shell. List their comments on a chalkboard or flip chart.

---

## Leader Notes

---

the United States, lays white-shelled eggs, while the American breeds, such as the Rhode Island Red, Plymouth Rock, and New Hampshire, lay brown-shelled eggs. Shell color has no influence on the nutritional content of an egg. The shape and size of an egg are influenced by genetics, nutrition, and the environment of the hen.

### Shell Membranes

On the inner surface of the shell are two soft shell membranes which surround the white and yolk of the egg. These membranes provide a barrier against the invasion of microorganisms into the liquid of the egg. Note the air cell that is found at the large end of the egg between the two shell membranes. A newly laid egg has a very small air cell. As the egg cools at time of laying from a temperature of 107°F to the atmospheric temperature, the contents contract, creating a vacuum which draws air through the larger, more porous end of the shell. As a result, the air cell is formed at the large end of the egg. As the egg ages, the loss of moisture increases the size of the air cell. Storing eggs in a warm dry environment speeds up this loss of moisture. The depth of the air cell of an egg is the major factor in determining its quality; the deeper the air cell, the lower the quality.

Have members break a fresh egg onto a glass plate. Examine the shell carefully and observe the tiny pores, shell membranes, and the air cell.

Place a cool whole egg into a jar of hot tap water. Observe the air bubbles arising from the shell surface of the egg. Have members explain why this happens.

Hand out the diagram showing the parts of an egg. Have members carefully examine and identify the various parts of an egg. With a sharp knife, cut across the thick white. The thin watery material that flows out of the opening is the inner layer of thin white.

### The Albumen (White) and Yolk

Note the two white cords that are attached to the yolk and imbedded in the thick white. These two cords, called the **chalaza**, hold the yolk in the center of the egg. These cords disappear as the egg ages.

The thick white of the egg contains primarily water and protein. The yolk contains large amounts of fat, vitamins, and minerals that are essential for normal embryonic development. Note the white spot on the surface of the egg. This is the germ spot or living part of a fertilized egg.

As an egg ages after it is laid, physical and chemical changes take place. Moisture is lost from the white and yolk, which causes the air cell to increase in depth. The thick white turns to thin white. The yolk absorbs water from the white, which stretches the yolk sac, resulting in a large flat yolk. These chemical and physical changes do not affect the nutritional content of the egg, but do affect the functional and physical appearance of the cooked egg.

### DIALOGUE FOR CRITICAL THINKING

1. Why do various species of birds have different colored egg shells?
2. What are the four major parts of an egg?
3. Describe the difference in the physical appearance of a high and low quality uncooked egg.
4. How do you feel about being able to recognize the many parts of an egg?
5. How do you think this egg compares to a human ovum or egg? Discuss the differences.

### **GOING FURTHER**

1. Study what causes color variations in egg yolks.
2. Study what affects nutritional differences in eggs.

---

---

**CRACKING UP—WHAT'S IN AN EGG**  
**POULTRY SCIENCE, LEVEL II**  
**Member Handout 1**

**Parts of an Egg**

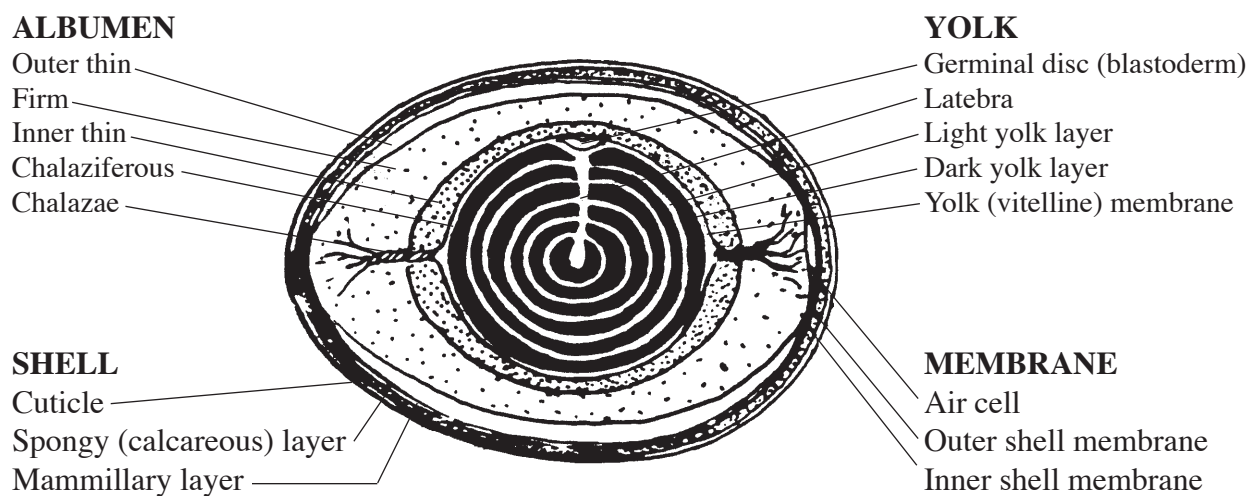

Source: Egg Grading Manual, USDA Agricultural Handbook No. 75, July 1961.



---

# Making and Using an Egg Candler

*Poultry Science, Level II*

## What Members Will Learn . . .

### ABOUT THE PROJECT:

- To learn how to construct a simple, inexpensive candler
- To learn the methods and reasons for candling eggs
- To observe the differences between a fertile and nonfertile egg
- To observe the differences in various qualities of eggs

### ABOUT THEMSELVES:

- Their feelings about their ability to make and use an egg candler
- Their feelings about being able to observe or see inside of a life form without harming or destroying the life

## Materials Needed:

- An oatmeal box, a shoebox, or a tin can
- An extension cord and a 60-watt bulb
- A dark room
- Fertile and nonfertile eggs, and high and low quality eggs (obtain about one week before the meeting)
- Member Handout 2 - "Wood Box Egg Candler, Canded Eggs"

**ACTIVITY TIME NEEDED:** 45 MINUTES

## ACTIVITY

You can construct a simple, inexpensive candler from an oatmeal box, a tin can, or wood box as shown in the Member Handout 2. Cut a one-inch hole in the side of a box or can. Obtain an extension cord and mount a 60-watt bulb inside the candler.

To candle eggs, you hold the eggs in front of a bright light in a darkened room. Eggs can be candled individually by holding the large end in front of the light, rotating gently, and observing the contents illuminated by the light rays. During candling, the following characteristics can be observed: the presence or absence of embryonic development, and those characteristics that indicate the interior and exterior quality of an egg. An infertile (market egg) will have a well-defined yolk shadow, air sac, and **chalaza** (cord-like attachment of yolk to the albumen or egg white). A living embryo will have a small dark spot (on the yolk) with a distinct network of blood vessels coming from the spot. A dead germ will have a dark spot on the yolk without the clear network of blood vessels.

Eggs purchased in the supermarket have been mass candled, which involved passing a large number of eggs at one time over a bright light.

## Leader Notes

Have members construct an egg candler.

Refer to Member Handout 2 - "Wood Box Egg Candler, Canded Eggs."

Several days prior to the meeting, purchase three to four eggs per member at the store. Place half the eggs in the refrigerator and store the other half at room temperature. Have members candle the eggs and note differences in the air cell depth, yolk movement, and prominence of the yolk shadow of the eggs.

---

## Leader Notes

---

Hold the large end of the egg up to the candling light at a 45-degree angle. This allows you to observe the air cell, the yolk, and the white. Hold the egg between your thumb and first two fingers. Then, by turning your wrist quickly, you can gently cause the inside of the egg to twirl.

Observe the depth of the air cell, which is the distance from its top to its bottom when the egg is held air cell up. In a high quality (grade AA) egg, the air cell is small, not more than  $\frac{1}{8}$ -inch deep. As an egg declines in quality, the air cell increases in depth from evaporation of moisture from the egg. A grade A egg can have an air cell depth up to  $\frac{3}{16}$ -inch. An egg with an air cell depth greater than  $\frac{3}{16}$ -inch is grade B.

A high quality egg's yolk moves only slightly when twirled because the yolk is surrounded by a dense layer of thick white. As the egg ages or deteriorates in quality, the white thins and the yolk tends to move more freely and approaches the shell more closely. Then the yolk is more visible and darker.

The condition of the white influences the behavior of the yolk when the egg is twirled. Blood or meat spots become apparent when the egg is candled. Eggs with blood or meat spots over  $\frac{1}{8}$ -inch in diameter are classified as inedible. Eggs with spots smaller than  $\frac{1}{8}$ -inch are classified as grade B. When determining the grade of an egg by candling, the lowest quality factor will determine the grade.

One week in advance of the meeting, set several eggs each day in an incubator. This will provide fertile eggs with from 1- to 7-day-old embryos.

Have members candle the eggs and classify them as infertile, living embryo, or dead germ.

Candling can be done as early as 3 days after the start of incubation to determine fertility, but is more accurate after 7 days, particularly with brown-shelled eggs. A fertile egg will have a small dark spot in the center of the egg with a network of blood vessels branching out. An infertile egg shows no evidence of development and has the appearance of a market egg when candled. Early dead germs (death prior to appearance of blood) are difficult to distinguish by candling. Eggs showing rings, streaks of blood or tissue adhering to the shell contain embryos that have died early in the incubation period.

### **DIALOGUE FOR CRITICAL THINKING**

1. What was your first impression of the egg candler you made?
2. How did you feel about seeing inside of an egg?
3. What problems did you have when candling the eggs?
4. What other instruments allow you to see inside or through something?
5. Compare candling to a doctor's use of an X-ray machine.

### **GOING FURTHER**

1. Visit a hatchery or egg processing plant and observe mass candling of eggs.
2. Demonstrate your candler to your class at school or arrange to demonstrate it at a grocery store.

---

---

**MAKING AND USING AN EGG CANDLER**  
**POULTRY SCIENCE, LEVEL II**  
**Member Handout 2**

**Wood Box Egg Candler**

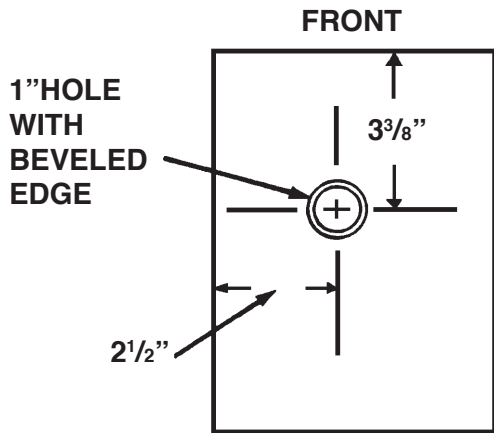

FIGURE 1

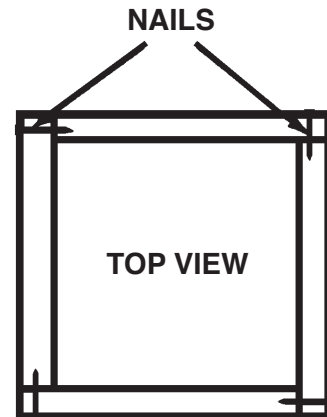

FIGURE 2

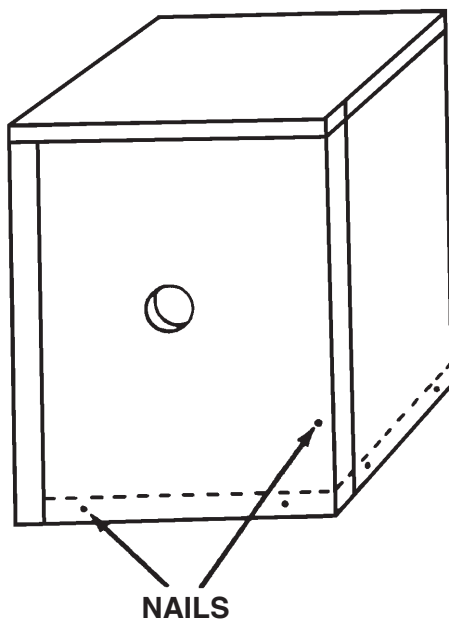

FIGURE 3

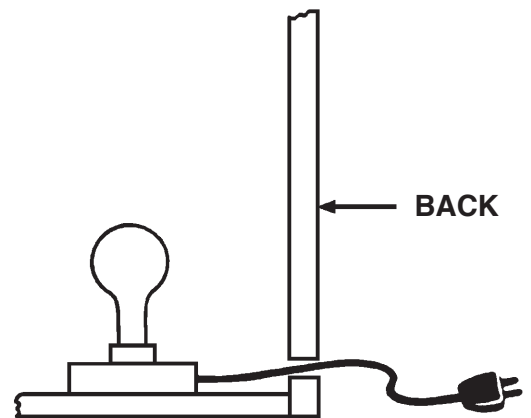

FIGURE 4

**MAKING AND USING AN EGG CANDLER**  
**POULTRY SCIENCE, LEVEL II**  
**Member Handout (Cont'd.)**

FIGURE 5-Candling Light

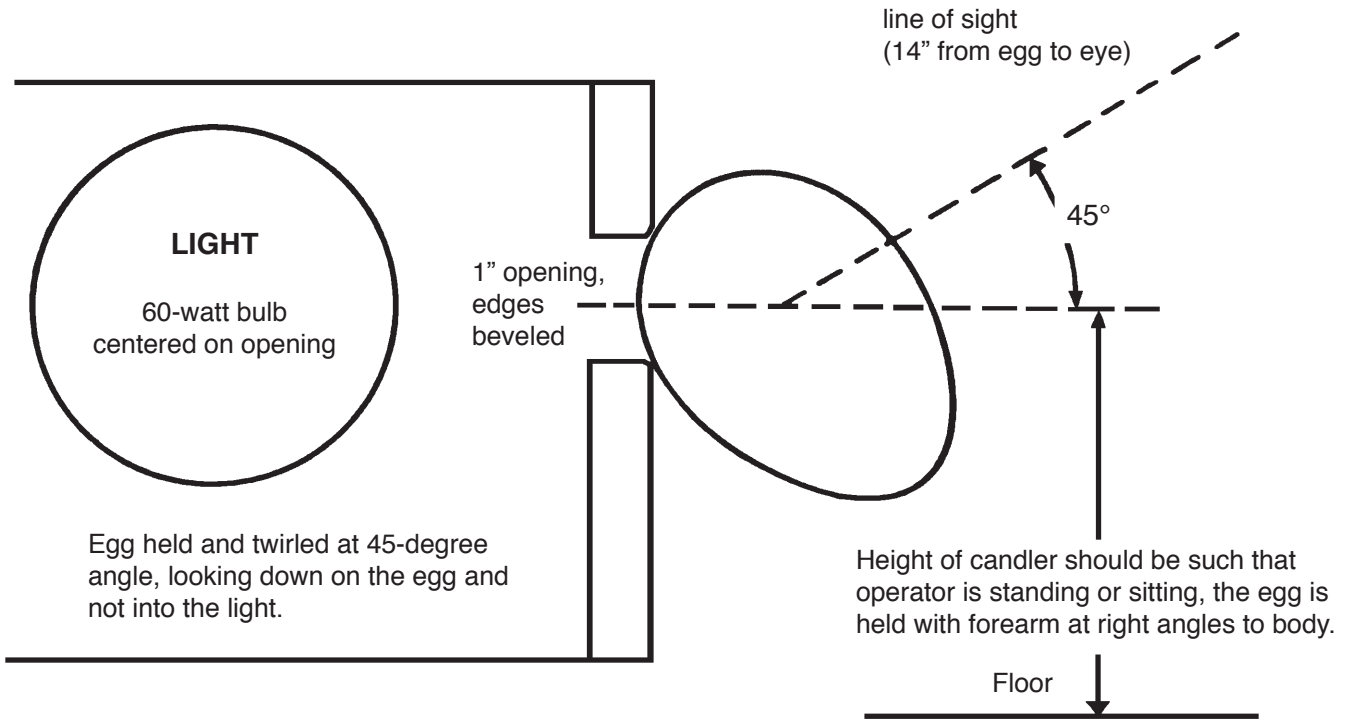
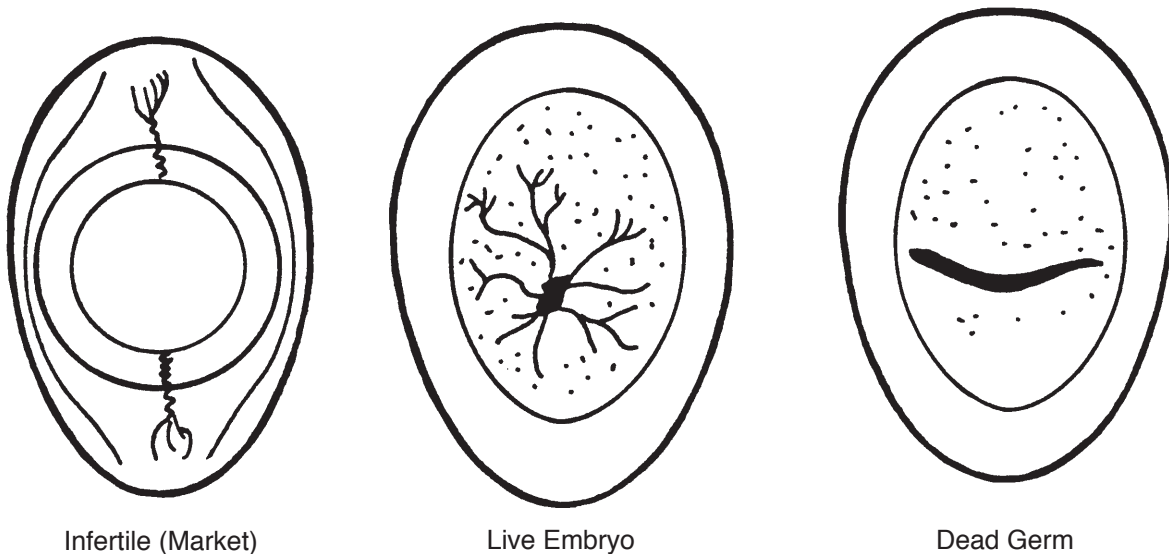

FIGURE 6-Candled Eggs (4-7 days)





# Constructing a Small Incubator

*Poultry Science, Level II*

## What Members Will Learn . . .

### ABOUT THE PROJECT:

- The two most important factors in hatching eggs
- Incubation factors for several poultry species
- How to build a small incubator

### ABOUT THEMSELVES:

- Their embryo development environment
- The importance of following directions

### Materials Needed:

- Handouts 3 and 4 - "Incubation for Eggs of Domestic Birds"
- Handout 5 - "Homemade Incubator with Automatic Temperature Regulator," plus all materials listed on this handout
- Hammer, screwdriver, tape measure, etc.

**ACTIVITY TIME NEEDED:** 60-120 MINUTES

## ACTIVITY

## Leader Notes

---

Building your own incubator and then using it to hatch eggs will be a very exciting project. You will get a lot of satisfaction out of constructing the incubator and then watching it work.

The operation of the incubator will increase your knowledge about the proper environment needed to hatch an egg.

You could make an incubator using a foam cooler as the outside shell of the incubator, rather than wood. The other components of the incubator would be the same in either case.

There are several companies which supply incubators and incubator parts. Their addresses are listed below:

Let members work in small groups to build the number of incubators desired.

G.Q.F. Manufacturing Co.  
P.O. Box 1552  
Savannah, GA 31498  
Phone (912) 236-0651

Lyon Electric Co., Inc.  
Marsh Farms Products  
2765 Main Street  
Chula Vista, CA 92001  
Phone (619) 585-9900

Stromberg's  
Box 400  
Pine River, MN 56474  
Phone (218) 587-2222

Val-A Company  
700 West Root Street  
Chicago, IL 60609  
Phone (312) 927-9442

---

## Leader Notes

---

Once your incubator is constructed, you need to operate it without eggs to master the temperature and humidity controls. When you are sure it is working properly, you are ready to begin your exciting project of hatching your own chicks.

### **DIALOGUE FOR CRITICAL THINKING**

1. What was the most difficult part of the incubator to make? Easiest?
2. How did it feel when you had finished the incubator?
3. What problems did you have in operating the incubator?
4. Tell about other things you have made and the problems or joys you've had.
5. Compare a human embryo development in a womb to that of a chick in an incubator. Consider time, temperature, humidity, how embryo is fed, etc.
6. Compare living environment for birds with that of other animals at various ages.

### **GOING FURTHER**

1. Try hatching eggs of other species.
2. Give a presentation on how you made your incubator.
3. Use your incubator to hatch eggs in your school classroom.
4. Use your incubator at a fair booth or window display.

# CONSTRUCTING A SMALL INCUBATOR

## POULTRY SCIENCE, LEVEL II

### Handout 3

#### Incubation Period and Incubator Operation for Eggs of Domestic Birds

Requirements	Chicken and Bantam	Turkey	Duck*	Muscovy Duck	Goose	Pheasant
Incubation Period (days)	21	28	28	35-37	28-34	23-28
Forced-Air Operating Temperature** (degrees F, dry bulb)	99 <sup>3</sup> / <sub>4</sub>	99 <sup>1</sup> / <sub>4</sub>	99 <sup>1</sup> / <sub>2</sub>	99 <sup>1</sup> / <sub>2</sub>	99 <sup>1</sup> / <sub>4</sub>	99 <sup>3</sup> / <sub>4</sub>
Humidity (degrees F, wet bulb)	85-87	83-85	84-86	84-86	86-88	86-88
Do not turn eggs after	19th day	25th day	25th day	31st day	25th day	21st day
Operating temperature during last 3 days of incubation (degrees F, dry bulb)	99	98 <sup>1</sup> / <sub>2</sub>	98 <sup>3</sup> / <sub>4</sub>	98 <sup>3</sup> / <sub>4</sub>	98 <sup>1</sup> / <sub>2</sub>	99
Humidity during last 3 days of incubation (degrees F, wet bulb)	90-94	90-94	90-94	90-94	90-94***	92-95
Open ventilation holes one-fourth	10th day	14th day	12th day	15th day	1st day	12th day
Open ventilation holes further if needed to control temperature	18th day	25th day	25th day	30th day	25th day	20th day

\* It has been reported that duck eggs hatch better in still-air incubators than in forced-air incubators.

\*\* For still-air incubators add 2-3°F to the recommended operating temperatures.

\*\*\* Better hatchability may be obtained if goose eggs are sprinkled with warm water or dipped in lukewarm water for half a minute each day during the last half of the incubation period.

# CONSTRUCTING A SMALL INCUBATOR

## POULTRY SCIENCE, LEVEL II

### Handout 4

#### Incubation Period and Incubator Operation for Eggs of Domestic Birds

Requirements	Guinea	Peafowl	Bobwhite Quail	Coturnix Quail	Chukar Partridge	Grouse	Pigeon
Incubation Period (days)	28	28-30	23-24	17	23-24	25	17
Forced-Air Operating Temperature* (degrees F, dry bulb)	99 $\frac{3}{4}$	99 $\frac{1}{4}$	99 $\frac{3}{4}$	99 $\frac{3}{4}$	99 $\frac{3}{4}$	99 $\frac{3}{4}$	99 $\frac{3}{4}$
Humidity (degrees F, wet bulb)	83-85	83-85	84-86	84-86	80-82	82-86	84-86
Do not turn eggs after	25th day	25th day	21st day	15th day	21st day	22nd day	15th day
Operating temperature during last 3 days of incubation (degrees F, dry bulb)	99	99 $\frac{1}{2}$	99	99	99	99	99
Humidity during last 3 days of incubation (degrees F, wet bulb)	90-94	90-94	90-94	90-94	90-94	90-94	90-94
Open ventilation holes one-fourth	14th day	14th day	12th day	8th day	12th day	12th day	8th day
Open ventilation holes further if needed to control temperature	24th day	25th day	20th day	14th day	20th day	21st day	14th day

\* For still-air incubators add 2-3°F to the recommended operating temperatures.







# Determining the Sex of Poultry

*Poultry Science, Level II*

## What Members Will Learn . . .

### ABOUT THE PROJECT

- The different methods of determining the sex of young and mature poultry
- The reasons for separating day-old male and female poultry

### ABOUT THEMSELVES:

- Secondary sex characteristics that occur at puberty
- Their feelings about the onset of puberty

### Materials Needed:

- Pictures, slides, or illustrations of various breeds and varieties of chickens

**ACTIVITY TIME NEEDED:** 45 MINUTES

## ACTIVITY

## Leader Notes

---

Various methods have been developed to determine sex of both day-old and adult poultry. Sex of day-old chickens, turkeys, ducks, geese, and guineas can be determined by these methods.

1. **Japanese Vent Sexing.** This method involves visual examination of the sex organ in the vent of the day-old bird. Structural differences between the male and female allows accurate determination of the bird's sex. This method requires considerable practice to develop speed and accuracy. An experienced poultry person can sex 400 to 600 birds an hour.
2. **Instrument Sexing.** This method involves insertion of an optical device into the intestinal tract of the day-old bird. The object is to view the immature gonads of the bird; two gonads means a male and one gonad indicates a female. Like the vent sexing methods, instrument sexing requires considerable practice.
3. **Autosexing.** The genetic code which determines what a bird looks like is carried on chromosomes. One chromosome carries the gene which determines the sex of the bird. This same chromosome carries other genes which result in differences in feather color, size, etc., based on the sex of the bird. Some of these differences appear in day-old chicks. For instance, day-old, barred male chicks have completely black down except for a white spot on top of the head, while the nonbarred females have all black down.

---

## Leader Notes

---

The sex of mature birds can usually be determined visually by observing differences in their secondary sex characteristics. As birds near the age of sexual maturity, their gonads (ovary in the female and testes in the male) increase the output of the male sex hormone **testosterone**. This hormone causes development of visual external physical characteristics that can be used to determine the sex of sexually mature birds.

In **chickens**, redding of the comb and wattles occurs. Normally the cockerel's comb and wattles are larger than the pullet's because of a higher blood level of testosterone. When the gonads of a chicken are inactive, such as during molting, the comb and wattles regress in size and lose their red color from a lower blood level of the hormone. Another influence of testosterone in the cockerel is development of male feathering on the hackles, back, and tail. The feathers of the male are elongated with pointed tips while those of the female are short with rounded tips. Another characteristic of cockerels is that they crow.

An adult male turkey (**tom**) has a more developed and a brighter colored **snood** and **caruncle** than the **hen**. Also, the tom usually has a tuft of coarse hair on its breasts called the **beard**.

Adult waterfowl are difficult to sex except those breeds of ducks, such as the Rouen and Mallard, in which the male (**drake**) has more brightly colored plumage than the female (**duck**). In Pilgrim geese, the male (**gander**) is white-feathered and the female (**goose**) is gray-feathered. In most breeds of ducks, the tips of the middle tail feathers on the adult drake curl forward. This does not occur on the duck. Sex of the adult goose can be determined by visual examination of the sex organ in the vent of the bird. The organ is much more developed in the gander than the goose.

Sexing adult **guineas** is very difficult because they differ so little in appearance. Usually, sex may be distinguished by the difference in the cry of the birds, and by the larger helmet, thicker wattles, and coarser head of the male. The cry of the female sounds like "buckwheat" or "put-rock," and is quite different from the one-syllable shriek of the male.

With a few exceptions, adult male chickens, turkeys, waterfowl, and guineas are larger in body size than the female. The sex of some breeds of mature chickens is easy to tell because the male has more brilliant colored plumage than the female. The Rhode Island Red, New Hampshire Red, and Brown Leghorn are examples of this characteristic.

### DIALOGUE FOR CRITICAL THINKING

1. Name three methods of determining sex in day-old poultry.
2. Name and discuss some of the physical differences in secondary sex characteristics of adult poultry.
3. What secondary sex characteristics in poultry were most difficult to identify? Easiest?

4. What are some secondary sex characteristics that occur at puberty in human males? Females?
5. What secondary sex characteristic do you feel will be the most difficult for you to accept? Why?
6. Discuss how you and your friends can help each other adapt to the frustrations associated with the onset of puberty?

### **GOING FURTHER**

1. Visit a poultry show, preferably one that has different breeds and varieties of poultry, and observe the differences in appearance of the males and females.
2. Make arrangements to visit a hatchery and observe birds being sexed.





---

# Maternal Bonding and Imprinting (Follow the Leader)

*Poultry Science, Level II*

## What Members Will Learn . . .

### ABOUT THE PROJECT:

- How bonding occurs in poultry
- The value of a bonding relationship in poultry
- How to identify the various bonding relationships

### ABOUT THEMSELVES:

- How they feel about bonding relationships
- The importance of their relationship with their parents or siblings

### Materials Needed:

- Facilities to raise two or three newly hatched chicks for a week

**ACTIVITY TIME NEEDED:** 1 WEEK

## ACTIVITY

A typical feature of maternal behavior in poultry is that the prospective mother, if allowed to follow her natural instinct, will withdraw from the flock before the young are hatched. The hen finds a secluded site for laying a nest full of eggs and then incubating them.

After the young hatch, bonding between the hen and chicks occurs because the hen usually prevents contact between her chicks and other hens or chicks by chasing the intruders away. Hens recognize their own chicks, and the chicks learn to recognize their own mother. The hen attracts her own chicks by calling and by “tidbitting” or pecking conspicuously at food or litter.

Chicks will form a bond with and follow the first animate object that they are exposed to several times after hatching. For example, if chicks are isolated after they hatch and exposed to a moving object, such as a toy or a human, they tend to form a bond with the toy or human. This relationship is called “imprinting” or “follow-the-leader” behavior.

### DIALOGUE FOR CRITICAL THINKING

1. What happened as you raised the chicks with an animated object?
2. How did you feel about attracting a chick to something other than its real mother?
3. What problems did you have doing this experiment?

## Leader Notes

Introduce this topic and then have members raise a newly hatched chick or two for one week with another animate object. Bring the chicks and objects back a week later to observe and discuss the bonding that occurred.

Discuss this attraction in other birds, wildlife, and other animals. Could this be called parenting? Divide members into small groups of two or three to discuss and report back.

Either purchase or hatch a few chicks and spend time with them each day. Expose them to an animated toy several times each day and observe how long it takes them to follow you or the toy. The imprinting process is most effectively demonstrated when chicks are separated from each other.

---

## Leader Notes

---

4. What similar experiences have you had?
5. In what other species have you observed “bonding”? Describe.
6. Have you observed bonding in humans? When? Where? How is it the same as or different from what you observed with the chicks?
7. What do you think are the long-term effects of bonding in chicks? In humans? How does bonding change over time in humans? What could destroy bonding?

### **GOING FURTHER**

1. Have someone in your group continue to raise the chicks all together after the first week to see how they adapt.
2. Videotape your second meeting to record the bonding that occurred.
3. Share your experiences with other classmates or groups.



# Preventing Cannibalism

*Poultry Science, Level II*

## What Members Will Learn . . .

### ABOUT THE PROJECT:

- Causes of cannibalism
- Ways to prevent cannibalism

### ABOUT THEMSELVES:

- Restrictions they have to help them protect themselves
- Behaviors they have that could be harmful to others

### Materials Needed:

- Member Handout 6 - "Different degrees of beak trimming and anti-peck devices"
- Mechanical devices - specs, blinders, peck guards, bits (optional)

**ACTIVITY TIME NEEDED:** 45 MINUTES

## ACTIVITY

## Leader Notes

---

**Cannibalism** in poultry happens when one bird pecks the feathers, combs, toes, or vent of other birds. If cannibalism isn't prevented, it can result in death or lowering of market value due to poor feathering and damaged bodies.

Usually the exact cause of cannibalism cannot be traced to any one factor. Cannibalism may start because of:

- Overcrowding or overheating—may cause birds to be uncomfortable.
- A lack of a nutrient in the feed—particularly protein, may cause the birds to peck penmates' feathers to satisfy their hunger for protein.
- Excessive light—can make birds nervous and allow them to better see wounds on penmates.
- Inadequate feeding and nesting space—increases the competition for feed and water.
- Mixing birds of different ages, colors, or stages of maturity—disrupts the social order of a flock.

There are several different methods for prevention and control of cannibalism. Prevention stops the development of bad pecking habits before they get started. In some cases, removing the cause(s) will end cannibalism.

**Beak trimming**, which is removal of a portion of the bird's beak, is the best preventative measure. Beak trimming can be done at any age. There is no one beak trimming program that fits all situations. Broiler chicks

---

## Leader Notes

---

If possible, plan to show or demonstrate some of these devices.

Give each member the handout “Different degrees of beak trimming and anti-peck devices” and do at least one of the following activities: 1) visit a hatchery and observe beak trimming of day-old birds. See if each member could actually trim the beak of one or two birds, or 2) observe a flock of birds that have been beak-trimmed or have been equipped with anti-peck devices.

are usually beak-trimmed at the hatchery. Egg-type chicks are usually beak-trimmed at 6 to 10 days and again at 12 to 14 weeks of age. Beak trimming is best done with an electric beak trimmer.

Control with **mechanical devices** such as specs, blinders, peck guards, or bits are used by some poultry raisers. These devices are attached to the bird’s beak and prevent pecking by either limiting their vision or preventing complete closure of the beak.

**Miscellaneous** methods that give variable results are: (1) providing other objects for the birds to peck, such as alfalfa hay, (2) increasing the salt content of the ration, and (3) darkening the interior of the pen or using red-colored lights. These adjustments make it more difficult for the birds to see bloody wounds on penmates.

### DIALOGUE FOR CRITICAL THINKING

1. How did the chick react after the beak was trimmed?
2. How did you feel about trimming the beak of a bird?
3. What problems did you or others have when trimming beaks? What is the main problem professionals have when trimming beaks?
4. What restrictions do you have (physically) or are imposed by your parents? Why do you have them?
5. What restrictions do you consider are for your own safety? Or are abusive?
6. What behaviors do your friends practice that you consider abusive? Why?
7. Why do you think people act in ways that hurt or make others feel sad?
8. What one human behavior do you feel should be prevented?

### GOING FURTHER

1. Discuss cannibalism in poultry as compared to cannibalism in humans practiced in some early societies.
2. Research the common causes of cannibalism to see which is the most prominent.
3. Give a presentation on the need for preventing cannibalism in poultry.

---

---

**PREVENTING CANNIBALISM**  
**POULTRY SCIENCE, LEVEL II**  
**Member Handout 6**

**Different Degrees of Beak Trimming and Other Anti-Peck Devices**

**BEAK TRIMMING**

1. Under 10 days



2. During growing period



3. Adult



**OTHER ANTI-PECK DEVICES**

1. Specs on laying hen





# The Peck Order

*Poultry Science, Level II*

## What Members Will Learn . . .

### ABOUT THE PROJECT:

- To define “peck order” in chickens
- How the peck order is established
- How the peck order affects the stability and performance of the flocks

### ABOUT THEMSELVES:

- Their experience with social status among peers and others
- How they feel about social and economic status among peers

### Materials Needed:

- Flock or small group of 6- to 10-week-old birds
- Activity Sheet 6 - “Peck Order Observations”

**ACTIVITY TIME NEEDED:** 45 MINUTES

## ACTIVITY

## Leader Notes

---

It has been known for some time that animals and birds form social organizations called **peck orders**. In a well-organized peck order, each bird has a certain **status** which refers to its position or rank in relation to others. The bird’s status can be either **dominant** or **subordinate** to others in the flock. Dominance is usually attained initially by **aggression**, or forcefulness. The opposite of aggression is **submission**. Submissive behavior is usually beneficial for smaller, weaker, and younger birds because it allows them to live with more aggressive, dominant birds.

Some major observations of the peck order among birds are:

- Aggressiveness is most apparent when birds are competing for something such as food.
- The social structure of a flock can be simple or very complex.
- Birds low on the peck order often get very little feed and water, appear to be nervous and frightened, and males rarely have an opportunity to mate.
- When adult strangers meet, they promptly establish a peck order.
- Although peck orders tend to be rather stable, physiological changes such as molting, can change the peck order in a flock.

Newly hatched chicks are not aggressive, but play fighting or “**sparring**” gradually appears and is common by the third week after hatching. Males become aggressive earlier than females; peck orders are evident among cockerels by 6 to 8 weeks and among pullets by 8 to 10 weeks. Typically, male chicks dominate females.

---

## Leader Notes

---

Peck orders may be simple or complex. In very small groups, **linear** peck orders are common and for a group of four could be shown as:

A----->B----->C----->D

where A pecks B, C, and D; B pecks C and D, but is pecked by A; C pecks only D; and D is pecked by all.

Have the youth visit a flock of chickens, preferably ones that are 6 to 10 weeks old, and observe evidences of aggressive or dominant behavior. Use Activity Sheet 6 - "Peck Order Observations" to record findings.

A more complicated peck order might include a "**pecking triangle,**" thus:

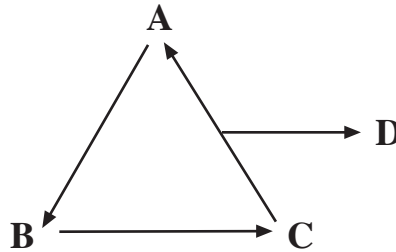

where A pecks B, B pecks C, C pecks A, and all three in the triangle peck D.

### DIALOGUE FOR CRITICAL THINKING

1. What happened when you observed for peck order?
2. Were the aggressive or submissive birds easiest to identify?
3. What behavior did you observe the most?
4. What experiences have you had at school or in groups that are similar to those you observed in the birds?
5. How has your social status changed since you were in the first grade? Would you like your status to change? Why or why not?
6. What advantages or disadvantages are there for someone who is a leader? A follower?
7. Why do you think some people are more aggressive or submissive than others?
8. How does it feel to be at the top or the bottom of a social order?
9. What would an economic "peck" order be? Discuss and define.

### GOING FURTHER

1. Share your experience with your class or others.
2. Individually identify a small group of 6- to 10-week-old birds and observe them to determine their peck order.







# Economics of Broiler Production

*Poultry Science, Level II*

## What Members Will Learn . . .

### ABOUT THE PROJECT:

- Meat production strains of chicks
- Pounds of feed it takes to produce a pound of live chick
- Cost of producing a pound of meat

### ABOUT THEMSELVES:

- How they feel about raising broilers for profit
- Their feelings about the production phase of a business
- Their feelings about raising birds for food

### Materials Needed:

- Facilities and equipment to raise specified number of broilers (optional)
- Activity Sheet 7 - “Broiler Production Planning”
- Activity Sheet 8 - “Broiler Budget”
- Activity Sheet 9 - “Broiler Production Record”

**ACTIVITY TIME NEEDED:** 60 MINUTES

## ACTIVITY

The intent of this lesson is to help you to raise some broilers either for family use or for selling to others. You should have studied several previous lessons about the specifics of caring for day-old chicks.

First we will consider a few basic questions that must be answered in order to prepare for your broiler project.

Think about planning for the costs involved in producing broilers. We use a budget to help determine if there is at least a possibility of making a profit. As we prepare the budget we must consider production goals. Also, there will be some fixed costs for equipment and facilities and other variable costs for feed and other materials. Finally, we must consider how much income we can expect to make.

If you decide to actually raise broilers, you must keep accurate records to determine if you are within your budget and whether or not you can raise broilers efficiently enough to make a profit.

### DIALOGUE FOR CRITICAL THINKING

1. What happened the day you received your chicks?
2. How did you feel about being responsible for this number of chicks?

## Leader Notes

Give each member a “Broiler Production” planning and activity sheet. Let members discuss the planning sheet in small groups. Have each group report their findings for total group discussion.

Give each member a “Broiler Budget” activity sheet to discuss in their small groups before reporting back to the entire group. You may want to give members these planning and budget sheets a week prior to this meeting to give them a chance to research some answers from the local community.

Give each member planning to actually raise some broilers a “Broiler Production Record.” Make plans for the members to visit the production locations to observe and discuss the experiences encountered. You may want to visit immediately after chicks are purchased and again in two or three weeks. Compare actual records with budget proposals after birds are sold.

---

## Leader Notes

---

3. What problems did you have in raising the chicks?
4. What similar experiences have you had with other animal or bird projects?
5. What did you learn from this experience? How will it help you in future business endeavors?
6. How will the planning and budgeting process for broilers help you with your personal budget? Why?

### **GOING FURTHER**

1. Organize your poultry club to raise broilers as a community project for a club money raising activity.
2. Share your experiences by giving presentations to your school class, other members, or community groups.
3. Consider raising broilers several times a year.

---

---

**ECONOMICS OF BROILER PRODUCTION**  
**POULTRY SCIENCE, LEVEL II**  
**Activity Sheet 7**

**Broiler Production Planning**

1. What hatchery is available or should be used to order chicks from?
  
  2. Will you purchase straight-run or all cockerels?
  
  3. What strain of broiler chicks should be ordered?
  
  4. What month or date should the project begin?
  
  5. What live weight of bird do you plan to sell?
  
  6. Will you sell birds live or dressed?
  
  7. What types of feeds or rations will be needed?
  
  8. Is proper feed available from your local feed store?
  
  - \*9.
  
  - \*10.
- \* List other questions you might have.

**ECONOMICS OF BROILER PRODUCTION**  
**POULTRY SCIENCE, LEVEL II**  
**Activity Sheet 8**

**Broiler Budget**

**A. PERFORMANCE GOALS:**

Projections

Average live weight (straight-run)\*  
 Feed conversion  
 Dressing yield  
 Mortality

4.0 lb at 7 weeks  
 2.1 lb/lb live wt  
 73% of live wt  
 4%

**B. INVESTMENT:**

Building-use existing building  
 Equipment-used equipment  
 TOTAL

\$ \_\_\_\_\_  
 \$ \_\_\_\_\_  
 \$ \_\_\_\_\_

**C. INCOME:**

Sold Live - \_\_\_ lb live weight/bird  
 X \_\_\_ c/lb. X \_\_\_ birds  
 Sold Dressed - 73% X \_\_\_ lb. live  
 weight/bird = \_\_\_ lb. dressed wt/bird  
 X \_\_\_ c/lb. X \_\_\_ birds  
 TOTAL

\$ \_\_\_\_\_  
 \$ \_\_\_\_\_  
 \$ \_\_\_\_\_

**D. EXPENSES:**

Feed- \_\_\_ lb. live wt./bird X \_\_\_ feed  
 conversion X \_\_\_ feed cost/lb. X \_\_\_ birds  
 Interest-equipment \_\_\_ initial cost  
 X \_\_\_ interest rate-  
 Cost of:  
 Chicks  
 Fuel  
 Litter  
 Misc.  
 TOTAL

\$ \_\_\_\_\_  
 \$ \_\_\_\_\_  
 \$ \_\_\_\_\_  
 \$ \_\_\_\_\_  
 \$ \_\_\_\_\_  
 \$ \_\_\_\_\_

**E. RETURN TO MANAGEMENT AND LABOR**  
 (Income minus Expenses)

\$ \_\_\_\_\_

**ECONOMICS OF BROILER PRODUCTION**  
**POULTRY SCIENCE, LEVEL II**  
**Activity Sheet 9**

**Broiler Production Record**

**FEED RECORD**

Record the kind, amount and value of feed each time a purchase is made or a quantity of home raised feed is set aside for the project.

Date	Kind of Feed (grain, mash supplements, etc.)	Quantity of Feed (lbs.)	Cost	Remarks: beginning ration, feed changes, feeding troubles, etc.
Total Feed Costs			\$	

**Production Summary**

1. Breed of Chicks purchased (circle one) \_\_\_\_\_ Straight-run    Sexed
2. Date project started \_\_\_\_\_ ended \_\_\_\_\_
3. Number days of project \_\_\_\_\_
4. Number of birds started (a) \_\_\_\_\_  
 Number of birds raised (b) \_\_\_\_\_  
 Number of birds that died (c) \_\_\_\_\_
5. Percent death loss (line 4c divided by line 4a X 100)= \_\_\_\_\_ %
6. Pounds of feed used \_\_\_\_\_
7. Pounds of live poultry produced \_\_\_\_\_
8. Pounds of feed to produce a pound of bird (divide line 6 by line 7) \_\_\_\_\_

**ECONOMICS OF BROILER PRODUCTION**  
**POULTRY SCIENCE, LEVEL II**  
**Activity Sheet 9 (continued)**

**Broiler Production Record (Cont.)**

Other Things Learned:

1. What was your brooder house temperature? 1st week \_\_\_\_ 2nd week \_\_\_\_ 3rd week \_\_\_\_ 4th week \_\_\_\_  
 5th week \_\_\_\_ 6th week \_\_\_\_ 7th week \_\_\_\_
2. What type of ventilation was used? \_\_\_\_\_
3. What type of heat source was used? \_\_\_\_\_
4. What type of litter was used? \_\_\_\_\_
5. What type of feeder was used? \_\_\_\_\_ How many? \_\_\_\_\_
6. What type of waterer was used? \_\_\_\_\_ How many? \_\_\_\_\_

**FINANCIAL SUMMARY**

**Income:**

Date	Items Sold or Used at Home (Indicate Which)	Quantity	Amount
_____	_____	_____	\$ _____
_____	_____	_____	\$ _____
_____	_____	_____	\$ _____
_____	_____	_____	\$ _____
		Total	\$ _____

**Costs:**

Date	Items Bought, Used, Labor Costs, Value of Home Grown Products	Quantity	Amount
_____	_____	_____	\$ _____
_____	_____	_____	\$ _____
_____	_____	_____	\$ _____
_____	_____	_____	\$ _____
		Total	\$ _____

**Summary:**

Total Project Income \$ \_\_\_\_\_  
 Total Project Costs \$ \_\_\_\_\_  
 How Much Money Made or Lost \$ \_\_\_\_\_



# Poultry Furniture

*Poultry Science, Level II*

## What Members Will Learn . . .

### ABOUT THE PROJECT

- Equipment needed for small farm flock
- Purpose for each piece of equipment

### ABOUT THEMSELVES

- Equipment needed for their health and safety
- Equipment (or furniture) they have that makes life easier or more comfortable, but is not necessary

### Materials Needed:

- Several poultry equipment catalogs
- Samples of small flock equipment (optional)
- Activity Sheet 10 - “Poultry Furniture”
- Activity Sheet 11 - “People Equipment-Furniture”

**ACTIVITY TIME NEEDED:** 45 MINUTES

## ACTIVITY

Many different feeders and waterers can be used in the poultry house. Equipment for small flocks and for large flocks is very different for each situation.

Compare the different styles of feeders, waterers, and other equipment. Notice the wide range of equipment available to a producer.

Make a list of the equipment you would need for a small farm flock on your “Poultry Furniture” activity sheet. List the function or purpose of each piece of equipment. Discuss what equipment is necessary and what is convenient or makes caring for the flock easier.

Next, use your “People Equipment-Furniture” activity sheet to list all the pieces of equipment that are necessary for your health and safety, plus other items that you have that make life easier or more fun, but are not necessary.

## DIALOGUE FOR CRITICAL THINKING

1. How did you feel about your list of poultry equipment? What items did everyone list?
2. Why do you think some feeders have wire or a reel over the top?
3. Why are fans needed in a poultry house?

## Leader Notes

Obtain an equipment catalog that has a selection of different equipment. You should have more than one catalog as small flock equipment will be in a different catalog than large commercial equipment.

Hand out “Poultry Furniture” activity sheet. Let two or three members work together. Have each group discuss their lists.

Discuss the difference between necessary and nice or convenient. Have members circle five to ten items needed most.

---

## Leader Notes

---

4. Discuss with your group your list of necessary or nice pieces of equipment or furniture in your house.
5. Which list was longer, necessary, or nice?
6. How did you decide what was really necessary?
7. How did you feel about the differences between you and your friends' lists of "nice" things?

### **GOING FURTHER**

1. Compare differences in equipment needed for a large commercial producer and a small farm flock.
2. Compare differences in equipment and housing for baby chicks as opposed to a laying house.
3. Discuss confinement versus free roam egg production.

---

---

**POULTRY FURNITURE**  
**POULTRY SCIENCE, LEVEL II**  
**Activity Sheet 10**

**Poultry Furniture**

List the equipment you would need for a small farm flock of laying hens or for raising a few day-old chicks for broilers.

Equipment	Function	(Check one)	
		Necessary	Nice





# Types of Poultry Housing

*Poultry Science, Level II*

## What Members Will Learn . . .

### ABOUT THE PROJECT

- To identify several types of poultry housing
- To match age and type of bird with proper housing type

### ABOUT THEMSELVES

- Differences in human housing in their community and around the world
- Their feelings about housing or room needs for various ages of people

### Materials Needed:

- Magazines, catalogs, library books, and other pictures of different types of poultry housing
- Pictures of human houses from around the world
- Scissors, glue, scrapbooks

**ACTIVITY TIME NEEDED:** 60 MINUTES

## ACTIVITY

## Leader Notes

---

There are many examples of poultry housing. They all have the same function—that is, to provide shelter and a healthy environment for the birds, as well as a pleasant environment for the caretaker. Some are very elaborate and others are simple, depending on the purpose.

Collect pictures of poultry houses from magazines and catalogs or make photocopies from library books. Paste your pictures in a scrapbook and arrange them by type of house and/or age and type of poultry they are best suited for.

Assist members by providing magazines, catalogs, etc., with poultry and human housing pictures.

### DIALOGUE FOR CRITICAL THINKING

1. How many different types of houses did you find?
2. What was similar, different about most houses?
3. What are the advantages and disadvantages of environmentally-controlled houses versus open-sided houses?
4. What types of houses are best for young chicks? Laying hens? Why?
5. What type of house do you prefer?
6. What are the differences between hospital baby nurseries and rest home housing for the elderly?

---

## Leader Notes

---

7. How are homes for Eskimos different from yours or homes for people who live in the the tropics?
8. Compare homes built 100 years ago to those of today.

### **GOING FURTHER**

1. Exhibit your scrapbook at the county fair.
2. Give a talk to your school class about poultry and human housing around the world.
3. Tour poultry facilities of different types in your area.



# How Birds Adapt to Their Environment

*Poultry Science, Level II*

## What Members Will Learn . . .

### ABOUT THE PROJECT:

- How birds respond to changes in their environment
- How the environment affects productivity and the quality of eggs and meat
- What humans do to help birds adapt to their environment

### ABOUT THEMSELVES:

- How their body adjusts to changes in temperature, humidity, air movement, and light
- What humans do to make their environment more comfortable
- The environmental factor that affects their comfort the most

### Materials Needed:

- Handout 7 - “Interior and Exterior Views of a Modern Poultry House”

**ACTIVITY TIME NEEDED:** 30 MINUTES

## ACTIVITY

## Leader Notes

---

Adequately protecting poultry from extreme changes in their environment is necessary for their welfare and productivity. Modern poultry housing helps control the environmental conditions surrounding poultry, making it possible to attain high productivity regardless of the external, or outside, environment surrounding the birds. Improving the birds’ environment also allows the caretaker to be more comfortable while taking care of the birds. The main environmental factors that birds have to adjust to are **temperature, humidity, air flow, and light**.

### Temperature

The fowl constantly loses heat to its environment because its normal body temperature of 105° to 107°F is usually higher than the air temperature. In addition to the heat produced by the bird, additional heat is added to the bird’s environment by the sun, artificial sources such as brooder stoves, and the decomposition of manure and litter in the house. The most comfortable temperature range for fowl depends on the species, age, and size of the bird. For example, because a baby chick is small and has a very thin feather coat, it needs a temperature of 95°F during the first week of its life. In contrast, a laying hen that has a full coat of feathers is most comfortable in a temperature range of 65° to 80°F.

---

## Leader Notes

---

Have members compare how they adjust to temperature changes with how birds adjust.

### How birds adjust to temperature changes.

#### Cold Weather

Fluff feathers  
Eat more feed  
Huddle together to share heat  
Increase activity

#### Hot Weather

Spread wings  
Eat less feed  
Lay on cool surfaces such as the ground  
Decrease activity  
Drink more water and pant

Reduced feed consumption reduces egg production and growth; increased feed consumption increases the cost of producing eggs and meat.

### Humidity

Birds tolerate a wide range of humidity. For birds on litter, a level below 30 percent may result in excess dust and above 75 percent may cause wet litter. High humidity during hot weather reduces the ability of birds to cool themselves by panting. During cold weather, high humidity makes the birds more uncomfortable.

### Light

Light striking the head of the bird triggers responses that influence reproduction, growth, and behavior. The “trigger” for this stimulation is the amount of light (day length) per 24 hours. Short day lengths (8 to 10 hours) or decreasing day lengths while birds are growing delays sexual maturity; increasing day lengths stimulates sexual maturity. A 14- to 17-hour day is required for optimum egg production. The intensity of the light that is needed varies between species. Birds respond more to the red end of the light spectrum than the blue-green end.

### Ventilation

Air movement is an important part of a bird’s environment. It provides oxygen to the birds and removes toxic gases such as carbon dioxide and ammonia, removes dust particles from the air, dilutes the microorganisms in the air, and regulates the temperature and humidity of the air.

Give members Handout 7 - “Interior and Exterior Views of a Modern Poultry House.” Have members list features that modify the bird’s environment. Have members compare these features to those found in their environment.

### Examples of how humans help birds adapt to their environment.

#### 1. Temperature:

- Insulation of poultry houses
- White roof surface to reflect heat
- Increase air flow during hot weather and decrease during cold weather
- Spray birds or house with water during hot weather
- Shade for birds in outdoor pens
- Cool water for birds during hot weather
- Supplementary heat for young birds

#### 2. Humidity:

- Reduce water spillage
- Ventilation to remove moisture from house

### 3. Light:

- Low light intensity in light-tight houses to discourage cannibalism
- Blue lights when catching broilers because people can see better in blue light than birds
- High light intensity to discourage broodiness in breeding turkeys
- High light intensity to stimulate day-old birds to eat and drink particularly important for poults because of poor eyesight at hatching
- Night lights during hot weather to stimulate feed consumption

### 4. Ventilation:

- Fans to supplement natural ventilation
- Increase air flow during hot weather, decrease during cold weather

## DIALOGUE FOR CRITICAL THINKING

1. What environmental adjustments do birds and humans both make?
2. What adaptations to control our environment are used for both birds and humans?
3. What adaptations are most critical for a chicken's environment? A human's?
4. Compare the necessity to control a bird's environment as opposed to yours.
5. What environmental factor affects you the most? Why?
6. Compare your family's environmental control costs to that of a chicken caged layer house.

## GOING FURTHER

1. Make arrangements to tour a modern poultry house.

---

---

**HOW BIRDS ADAPT TO THEIR ENVIRONMENT**  
**POULTRY SCIENCE, LEVEL II**  
**Handout 7 - page 1**

**Poultry House Caged Layers**

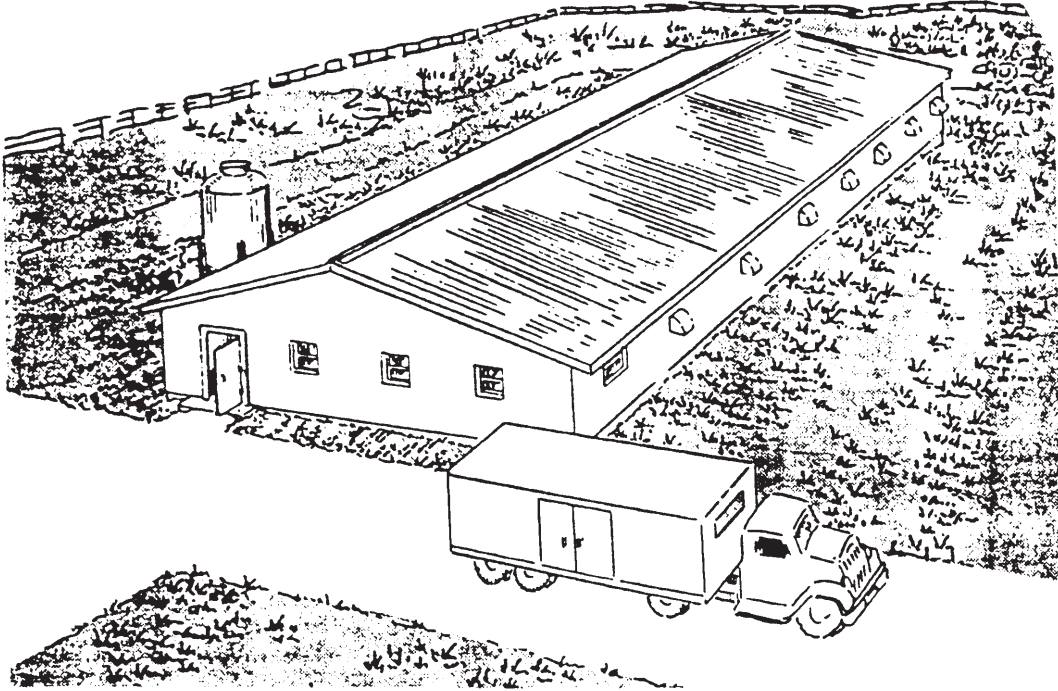

The control of environmental extremes in poultry housing has produced drastic changes in management systems for laying hens. The number of birds per foot of house has been doubled with reduced stress on the birds, increasing both quality and quantity of eggs.

This insulated, windowless, 38-foot wide house has a capacity of 60 birds per foot of length. The length can be varied in increments of 8 feet according to the size of the flock desired and the maximum capacity of the mechanical equipment installed.

Positive ventilation is provided by thermostatic controlled exhaust fans. A continuous adjustable inlet, under the eaves, can be adjusted to direct incoming air along the ceiling in cold weather or along walls and ceiling in warm weather.

# HOW BIRDS ADAPT TO THEIR ENVIRONMENT

## POULTRY SCIENCE, LEVEL II

### Handout 7 - page 2, continued

### Design Features

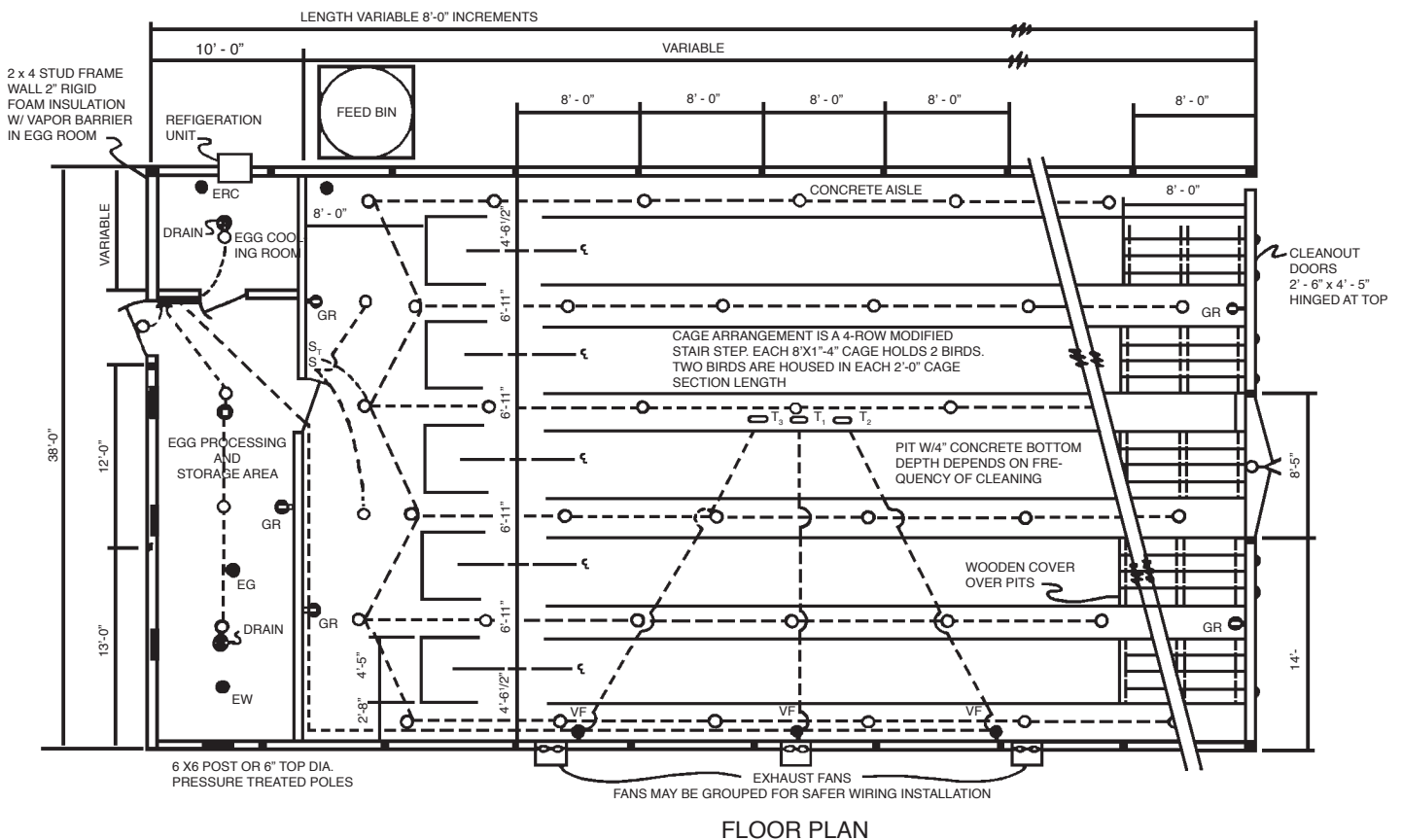

FLOOR PLAN

#### ELECTRICAL

- LIGHTING OUTLET
- DUPLEX CONVENIENCE OUTLET GROUNDED
- SPECIAL PURPOSE OUTLETS
  - EG—EGG GRADER
  - EW—EGG WASHER
  - ERC—EGG ROOM COOLER
  - FA—FEED AUGER
  - VF—VENTILATION FAN
- S SPST SWITCH
- S<sub>p</sub> SPST SWITCH W/PILOT LIGHT
- S<sub>t</sub> SPOT TIME SWITCH (230 VOLTS)
- T<sub>1</sub> LOW VOLUME THERMOSTAT
- T<sub>2</sub> MEDIUM VOLUME THERMOSTAT
- T<sub>3</sub> HIGH VOLUME THERMOSTAT
- DISTRIBUTION PANEL- (FUSE OR CIRCUIT BREAKER)
- D.P.D.T. SERVICE ENTRANCE SWITCH FOR USE WITH STAND-BY GENERATOR

#### NOTES

1. ALL PERMANENT WIRING SHOULD COMPLY WITH THE NATIONAL ELECTRIC CODE AND ANY OTHER LOCAL CODES IN AUTHORITY.
2. NON-METALLIC WIRING, SWITCHES, LAMP HOLDERS, AND RECEPTACLES ARE RECOMMENDED.
3. 1/2 HP OR LARGER MOTORS SHOULD BE CONNECTED TO 230 VOLTS.
4. LIGHTING CIRCUITS SHOULD BE EQUALLY DIVIDED ON NS VOLT SIDES OF THE SERVICE TO BALANCE LOAD ON SYSTEM. AMPERE LOAD ON ANY CIRCUIT SHOULD NOT EXCEED 80% OF RATING.
5. INCANDESCENT LAMPS, RATED AT 110 TO 120 VOLTS AND 25 WATTS ON 10'-0" CENTERS, ARE RECOMMENDED FOR USE WITH LIGHT COLOR CEILINGS OR WITH SHALLOW REFLECTORS. LAMPS SHOULD NOT BE MORE THAN 8'-0" ABOVE THE LOWEST FEEDER OR PROVIDE AT LEAST ONE FOOT CANDLE MEDIUM INTENSITY FOR BIRDS IN LOWEST CAGES.

#### SPECIFICATIONS

1. THE DESIGN IS EXPANDABLE BY 8'-0" SECTIONS OF LENGTH AND IS 36'-0" WIDE.
2. THE WINDOWLESS, CLEAR SPAN BUILDING USES TRUSSES 4'-0" O.C. WITH CAGES HANGING FROM BOTTOM CHORD OF TRUSSES.
3. THREE INCHES OF INSULATION ARE USED IN THE CEILING AND TWO INCHES IN WALLS
4. THE EGG COOLING ROOM USES TWO INCHES OF RIGID FOAM INSULATION.
5. THE DESIGN IS FOR EITHER FRAME OR POST CONSTRUCTION, WITH MEDAL ROOF AND SIDING.
6. THE VENTILATION SYSTEM USES EXHAUST FANS AND ADJUSTABLE SLOT INLETS.
7. THE MANURE IS REMOVED FREQUENTLY BY SCRAPER AND DEPOSITED IN A LOADER OR STORAGE AREA.

Based on W. VA Univ. Plan PO-123





# Types of Feathers and Their Functions

*Poultry Science, Level II*

## What Members Will Learn . . .

### ABOUT THE PROJECT:

- The four basic parts of a feather
- Basic structural parts of a feather
- The three types of mature bird feathers
- Three types of feathers according to location

### ABOUT THEMSELVES:

- Their personal features that serve similar functions as feathers on birds
- The importance of feathers in their everyday life

### Materials Needed:

- Magnifying glasses
- Samples of feather or live chicken
- Member Handout 8 - "Parts of a Feather"
- Member Handout 9 - "Types of Feathers and Location"
- Member Handout 10 - "Feather Locations"

**ACTIVITY TIME NEEDED:** 45 MINUTES

## ACTIVITY

## Leader Notes

---

Birds, like all vertebrates, have a skeleton, a backbone, and two pairs of limbs. However, only birds have feathers. Feathers are appendages of the skin. They may vary from soft down feathers that lie close to the body to body feathers and flight feathers. The down feathers help keep the bird warm. Body feathers follow the shape of the bird's body. The large feathers in the wing and tail are called flight feathers. Chickens also have hairlike feathers. At least once a year birds shed (**molt**) their feathers.

Feathers of a bird serve several different functions such as regulation of temperature, flight, and protection. We use them to identify secondary sex characteristics. Feathers come in many shapes, sizes, and textures. There are different kinds of feathers such as flight, fluffy, and male- and female-type feathers. Feather appearance differs between the sexes in the neck, back, saddle, and tail sections. In these areas, the tips of the male's feathers are pointed while those of the female are rounded.

At hatching, baby chicks are covered by down feathers which are soft, fine, and fluffy. These feathers are quickly replaced by several coats of coarser type feathers as the bird matures. When we look at a feather we can see that it has four distinct parts: the **quill**, **shaft**, **fluff**, and **web**.

Give each member a feather or have them draw a picture of a feather and label the four basic parts.

---

## Leader Notes

---

Point out these structure features by using a magnifying glass on real feathers or show diagram on member handout - "Parts of a Feather." Try smoothing a ruffled feather with your fingers and you will see the effect.

The basic structure of feathers is the same in all birds. The **shaft** (or stem), which projects from the skin, is often hollow filled only with spongy keratin. (Keratin is the horny substance of which the feather is made). There are many branches along either side of the shaft which form a flat surface called the **vane**, which is made up of barbs, barbules, and hooklets. The **web** is formed by barbs which are made up rows of smaller branches, called the barbules. The barbs are all the same, except perhaps for some variation in length, but the barbules differ according to the side of the barb from which they branch. Those pointing toward the tip of the feather bear hooklike projections, while those pointing toward the feather base are curved and hence may be called "bow" barbules. The barbules interlock with other barbs and help form a continuous smooth-looking appearance. If the connection should be broken they can easily be hooked together again. The **fluff** is a series of barbs which have no barbules. The side branches of the barbs are short and threadlike.

The feathers of an adult can be classified into three types: (1) **contour feathers**, (2) **plumules**, and (3) **filoplumes**. **Contour feathers** are the outermost feathers. These feathers vary a lot in both length and thickness. They range from the larger and stiffer primary and secondary flight feathers and the tail feathers to the softer and more delicate feathers that cover the body and give it shape.

Let members identify these feather types on a live chicken or provide them with samples for a collection. Give the Handout "Types of Feathers" as a take home review.

The **plumules** or down feathers make the underplumage of the bird. Each of these feathers has a quill and a soft head of fluffy branches because the barbules radiate freely and are not interlocked like they are in the contour feathers. This type of feather is often plucked from the breast to line the nest and keep the eggs warm. In certain species, such as the goose, these down feathers are gathered commercially to produce the lining for sleeping bags, coats, etc.

The **filoplume** feathers have a short, flexible, hairlike shaft with barbs that are confined to the tip of the feather. These are much smaller in size than the other feathers and stand up like hairs. They are easy to observe if you look at a plucked chicken.

Hand out "Feather Locations" as a guide for additional study.

Feathers are also named according to their location on the bird's body and function. There are usually ten flight feathers on the outer part of the wing, called the **primaries**. Often these are sharply pointed and asymmetric with a very narrow outer vane. The flight feathers next to the body are called **secondaries**. They have inner and outer vanes of almost equal size. The secondaries vary greatly in number depending on the length of the wing. **Covert** feathers shape the wing profile and generally insulate and protect the wing. **Contour** feathers are those on the body. We can guess the function of the down feathers from their use in sleeping bags and quilts. There are also feathers which serve chiefly for decoration and display.

### **DIALOGUE FOR CRITICAL THINKING**

1. What are some of the differences that you see in feathers?
2. What differences are there in how feathers feel?
3. Name the four basic parts of the feather.
4. Name the three general feather types.
5. List several functions of feathers.
6. What do people do or have that have the same functions as feathers.
7. What do people use feathers for?
8. Why have some feather substitutes been used?

### **GOING FURTHER**

1. Examine feathers from different species or breed varieties and compare.
2. Visit a poultry show and observe the different types of feathers on different species and breeds.
3. Research additional uses of feathers that benefit humans.

**TYPES OF FEATHERS AND THEIR FUNCTION**  
**POULTRY SCIENCE, LEVEL II**  
**Member Handout 8**

**Parts of a Feather**

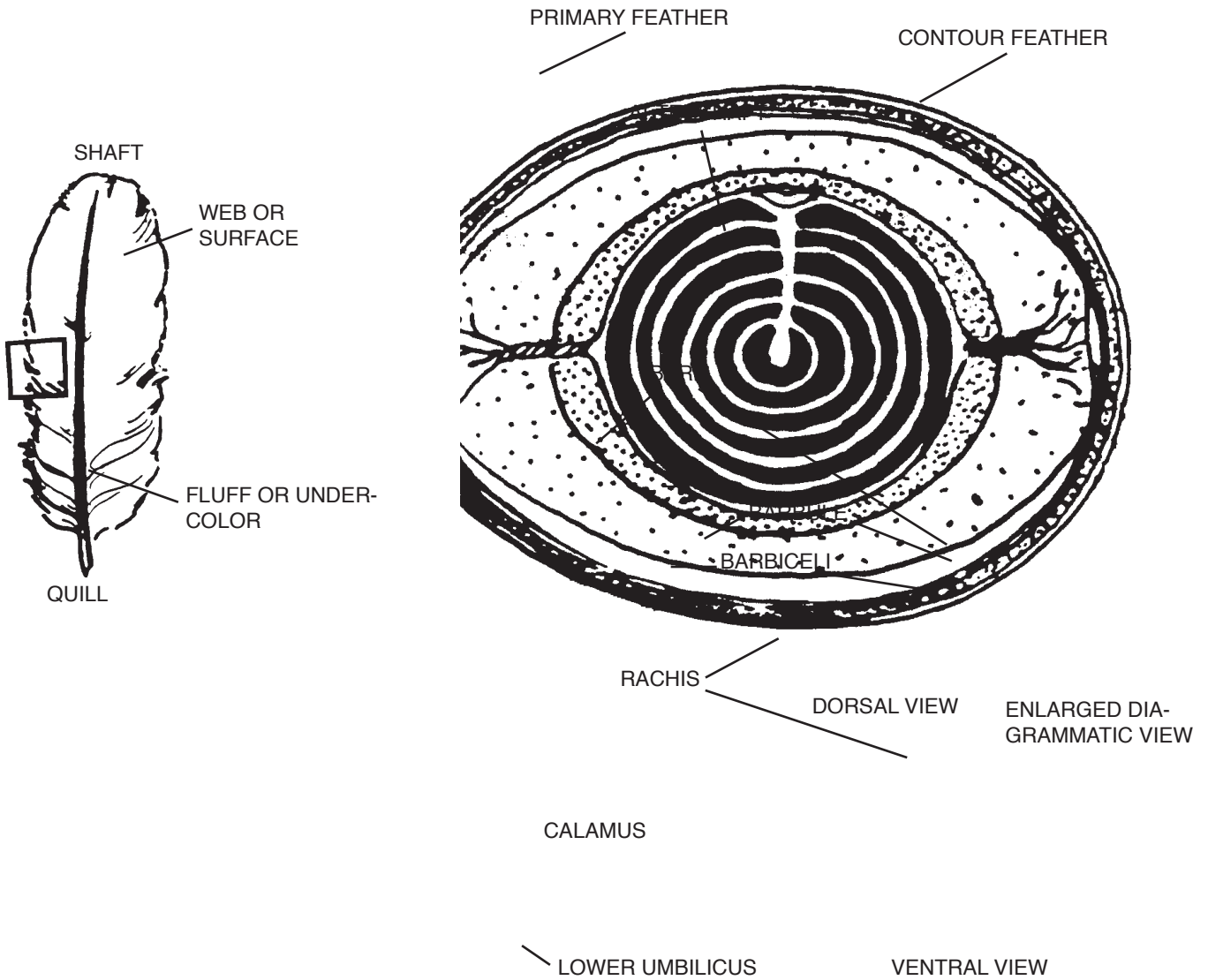

---

---

**TYPES OF FEATHERS AND THEIR FUNCTION**  
**POULTRY SCIENCE, LEVEL II**  
**Member Handout 9**

**Types of Feathers  
(Mature Bird)**



**Contour**



**Plumules**



**Filoplumes**

**Types of Feathers  
(Based on Location)**

**Primary Feathers**

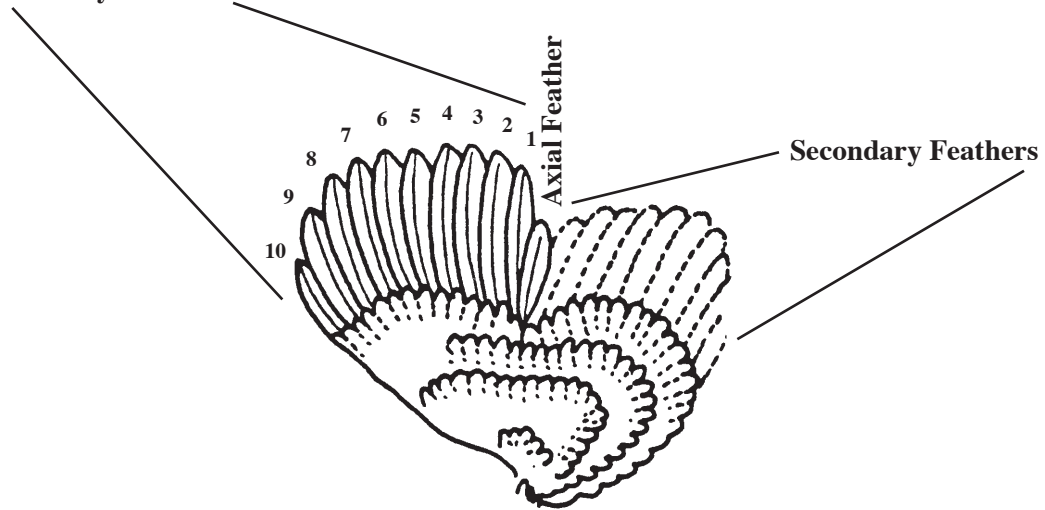

---

---

**TYPES OF FEATHERS AND THEIR FUNCTION**  
**POULTRY SCIENCE, LEVEL II**  
**Member Handout 10**

**Feather Locations**

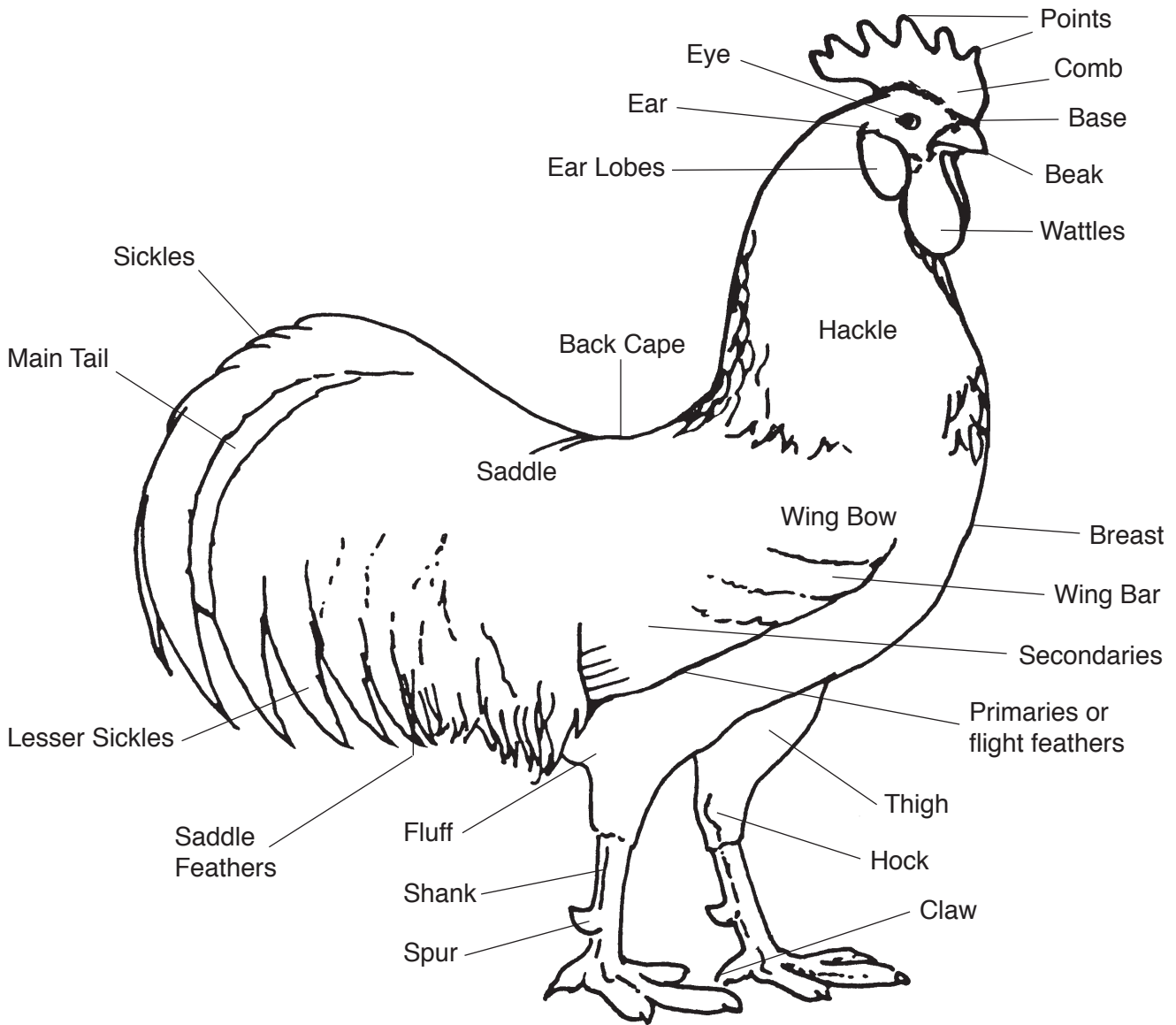



# Feather Colors and Patterns

*Poultry Science, Level II*

## What Members Will Learn . . .

### ABOUT THE PROJECT:

- Five types of feather patterns
- How feather patterns can be used to identify the breeds and varieties of chickens

### ABOUT THEMSELVES:

- Identify what people and other animals have that compare to feathers

### Materials Needed:

- Samples of feathers - the seven patterns discussed below (if possible)
- Pencils
- Activity Sheet 12 - “Standard Feather Patterns”
- Leader Key - “Standard Feather Patterns”

**ACTIVITY TIME NEEDED:** 30 MINUTES

## ACTIVITY

Feathers come in many different colors and have a variety of patterns, which help distinguish between breeds and varieties. Some of these patterns are: **penciled, spangled, mottled, laced, barred, striped, or tipped.**

Common feather colors are white, black, red, and buff. The different feather patterns usually contain two or more different colors. In some breeds or varieties of chickens, such as the New Hampshire Red and Brown Leghorn, the male has more brightly colored feathers than the female.

**Penciled** patterns are narrow markings, uniform in width, sharply defined and continue in an unbroken line following the contour of the feather. A **spangled** feather pattern is a distinct marking of a contrasting color at the tip of each feather, forming a V-shape with a rounded end. **Mottled** feathers are similar to spangled feathers, except that the markings are always white and found on a variable percentage of feathers, not all of them. **Laced** patterns have a border of contrasting color around the entire web of a feather. The border is usually narrow and uniform in width. The **barred** pattern describes alternate colored crosswise markings on a feather. **Striped** color patterns have a stripe which extends through the web and runs parallel with the outer edges of the feather and tapers to a

## Leader Notes

Hand out member activity sheets on feather patterns. You can have members complete the matching exercise prior to the explanation of the color patterns or have them fill in their sheets as you go. Have members try to identify the patterns on real feathers.

point near the lower end of the feather. **Tipped** feathers have white markings at the tips of feathers in mottled and spangled breeds.

### **DIALOGUE FOR CRITICAL THINKING**

1. How are feathers different?
2. What are some different color patterns of feathers?
3. Compare adaptability of birds and humans to different temperature changes.
4. What are feathers used for by people?
5. How are feathers important in your life?
6. What items used to be made with feathers that are now made with other materials?

### **GOING FURTHER**

1. Examine feathers from different species and compare.
2. Visit a poultry show and observe the different color and color patterns of the different breeds and varieties.
3. Make a display of feather color patterns to share with your club or classroom.
4. Develop a collection of feathers.
5. Go to an art or craft show and view uses of feathers.

---

---

**FEATHER COLORS AND PATTERNS**  
**POULTRY SCIENCE, LEVEL II**  
**Activity Sheet 10**

**Standard Feather Patterns**

Draw a line from the name of the feather pattern to the correct picture.

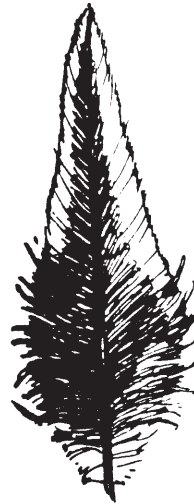

Penciled

Spangled

Mottled

Laced

Barred

Striped

---

---

**FEATHER COLORS AND PATTERNS**  
**POULTRY SCIENCE, LEVEL II**  
**Leader's Key**

**Standard Feather Patterns**

Draw a line from the name of the feather pattern to the correct picture.

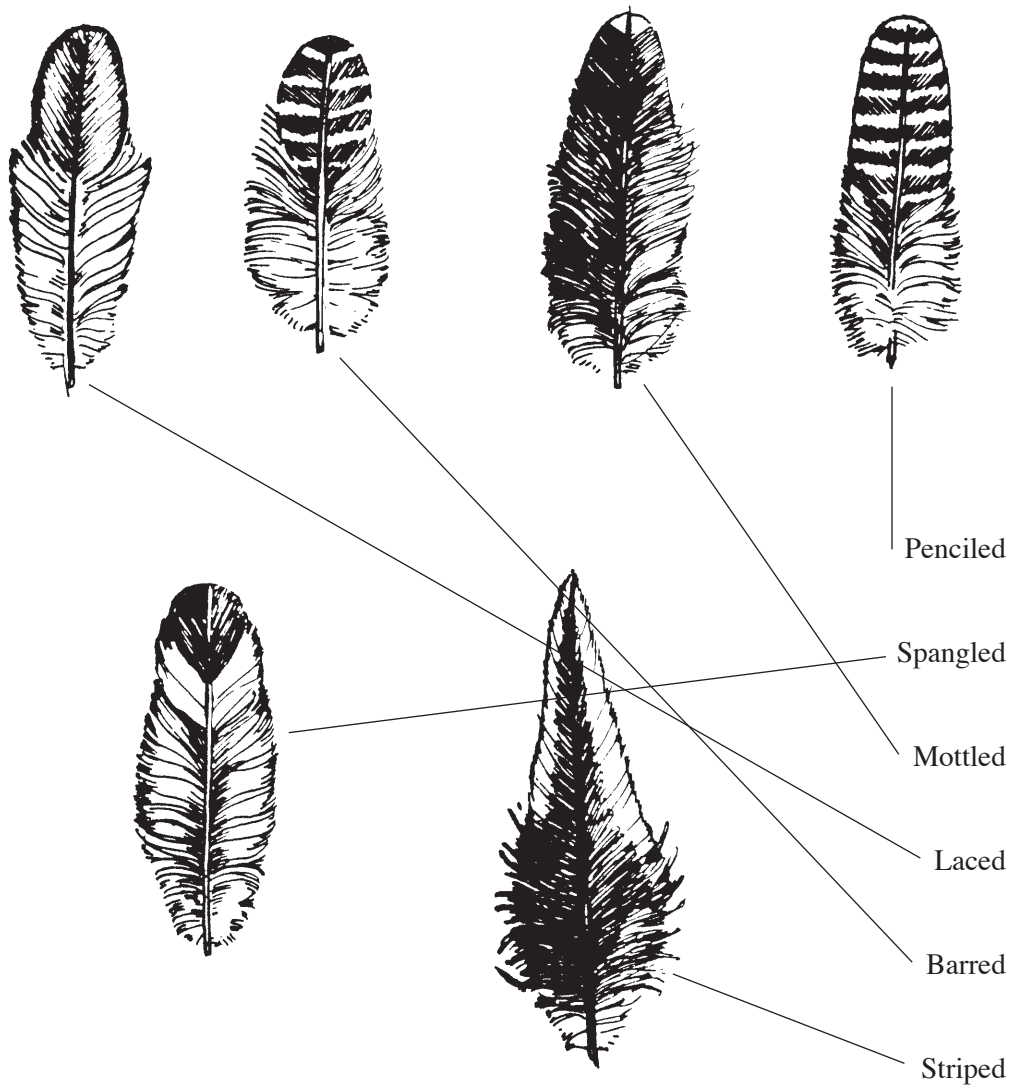



---

# Talking Like A Poultry Raiser

## *Poultry Science, Level II*

### What Members Will Learn . . .

#### **ABOUT THE PROJECT**

- To define and use twenty common poultry terms in sentences

#### **ABOUT THEMSELVES:**

- Their ability to make decisions and judgments in a competitive situation
- Their feelings about learning specific terminology for hobbies or a career

#### **Materials Needed:**

- List of terms and definitions

**ACTIVITY TIME NEEDED:** 60 MINUTES

---

### ACTIVITY

Understanding various poultry terms helps 4-H members expand their knowledge of poultry production and products. Whether a member is judging a class of chickens or eggs, reading about poultry, or simply talking with others, the ability to use correct terms will be very helpful.

**Quiz Bowl**—Definitions make excellent questions for quiz bowl use. To hold a quiz bowl, divide the 4-H'ers into two teams, read a definition or term to the teams, and give the team answering it correctly a point.

**Drawing**—Many of the terms can be understood more clearly by having your 4-H'ers make a drawing of what they think it means. Have them explain their drawings or sketches to each other.

**Charades**—Your 4-H'ers will enjoy acting out many of the terms as the rest of the group tries to figure out the term. To play charades, hand out or have them draw terms and let them take turns doing a charade.

#### **Poultry Terms**

Here are some terms that are used in describing and working with poultry and poultry production. Some uses are quite general and others are more specific. Quite a few terms are used only by the poultry judge or raiser of exhibition poultry. Some terms which have specific meanings for producers of waterfowl and turkeys are included in a separate list.

**Avian** - relating to or pertaining to birds.

---

### Leader Notes

Preparation for this meeting depends on the type of activity you select and whether you use poultry terms as the only topic for the meeting. Read the activities and select one or a combination of two or three. Included in this guide is an alphabetical list of general poultry terms and terms related to domestic waterfowl and turkeys.

---

## Leader Notes

---

***Axial feather*** - the short feather in the middle of the wing that separates the primary feathers from the secondary feathers.

***Bantams*** - miniature chickens, usually one-fourth to one-fifth the size of regular chickens.

***Barring*** - two alternating colors on a feather, running across its width.

***Bird*** - an individual of any avian species.

***Blade*** - the portion of a single comb below the points.

***Bow-Legged*** - a deformity in which the legs are farther apart at the hocks than at the feet.

***Brassiness*** - the light yellowish metallic cast commonly found in the plumage of white or partly white varieties.

***Breed*** - a group of chickens within a class with a distinctive body shape and having the same general feathers and body weight.

***Broody*** - the characteristic of birds to develop motherly instincts for setting on eggs and brooding chicks.

***Candling*** - examining the contents of an egg by holding it up to a light source in a darkened room.

***Capon*** - a castrated male chicken, usually processed at about 5 months of age for meat purposes.

***Carriage*** - the posture of the bird.

***Chalaze*** - white, twisted, cord-like structures which hold the yolk in the center of the white of an egg.

***Class*** - a group of chickens that has been developed in a particular region of the world.

***Close-feathered*** - feathers held tight to the body.

***Cockerel*** - a male chicken under one year of age.

***Comb*** - the fleshy protruding part on top of the head of a fowl.

***Condition*** - the state of a bird's health, including sufficient fleshing and cleanliness and brightness of plumage.

***Cornish Game Hen*** - an immature chicken, usually processed at 5 to 6 weeks of age, from one of the Cornish meat-type crosses. Cornish game hens weigh no more than 2 pounds ready-to-cook.

***Coverts*** - the feathers covering the base of the primary and secondary wing and main tail feathers.

***Crest*** - a round tuft of feathers on the top of the head of some chickens and ducks.

***Crop*** - the enlarged part of the gullet, between the neck and body, in which food is stored temporarily and softened for digestion.

***Crossbreed*** - the offspring of parents of different breeds.

***Crow Head*** - a narrow, shallow head with an abnormally long beak.

***Culling*** - removing unproductive or inferior birds from the flock.

***Cushion*** - a mass of feathers over the back and base of the tail of a chicken, giving it a rounded effect.

***Cuticle*** - a protective covering over the shell of the egg which partially seals the pores and makes the shell more water-resistant.

***Debeak*** - the removal of part of the beak of birds to reduce picking and egg eating.

***Defect*** - a fault that is considered in judging poultry.

***Disqualification*** - a serious deformity or a defect which prevents a bird from receiving an award.

***Down*** - the soft, fine, fluffy covering of a young bird.

***Dubbing*** - trimming the comb or wattles.

***Earlobe*** - a round, fleshy patch of bare skin on each side of the head, varying in size, shape, and color according to the breed.

***Embryo*** - the developing bird within the egg.

***Eviscerate*** - to remove the contents of the body cavity when processing poultry.

***Fowl*** - a collective term applying to chickens, ducks, geese, turkeys, and sometimes other avian species. Also, a marketing term used for mature chickens.

***Fryer (Broiler)*** - a young, meat-type chicken, usually processed at 7 to 10 weeks of age.

***Giblets*** - the heart, liver, and gizzard of poultry when used for meat.

---

## Leader Notes

---

**Hackle** - the rear and side neck feathers of a bird.

**Hen** - a female of many avian species. Also, a female chicken over one year of age.

**Hen-feathered** - a male having oval instead of pointed sex feathers in the hackle, saddle, wingbow, and sickles.

**Hock** - the joint between lower thigh and shank.

**Horn** - a term used to describe the various shades of dark color in the beak of some breeds such as the Rhode Island Red.

**Incubation** - applying heat to eggs to cause them to hatch.

**Keel** - the lower portion of the breast bone.

**Lacing** - a narrow border of contrasting color around the entire web of a feather.

**Leg** - the upper and lower thigh and shank in the live bird. The thigh and drumstick in processed poultry.

**Lopped Comb** - a comb which falls over to one side.

**Luster (Sheen)** - a glossy appearance to the feathers, due to the reflection of light rays.

**Molt** - the process of shedding old feathers and regrowing new feathers.

**Mottling** - spots of a color or shades different from the base color of the feather.

**Oil Gland** - a gland on the back at the base of the tail that secretes an oily fluid used in preening the bird's feathers.

**Ovary** - the part of a hen's reproductive system that produces the female germ cell and the yolk of the egg.

**Oviduct** - the part of the hen's reproductive system that produces the white, shell membranes, and shell of the egg.

**Plumage** - the collective term for the feather covering of a bird.

**Poultry** - a general term applied to all domesticated fowl.

**Primaries** - the long stiff feathers growing from outer segment of the wing.

**Pubic Bones** - the thin, rear portion of the hip bones that form part of the pelvis.

**Pullet** - a female chicken less than one year old.

**Roach Back** - a deformed, humped back.

**Roaster** - young, meat-type chicken, usually processed at 3 to 4 months of age.

**Saddle** - the rear of the back of a male fowl.

**Scales** - the thin, horny growths covering the shanks and feet.

**Secondaries** - the long, stiff wing feathers growing from the wing segment next to the primaries.

**Sex Feathers** - the pointed feathers in the hackle, back, saddle, sickles, and wingbow of a male fowl. In females, these sex feathers are oval.

**Shank** - the portion of the leg between the hock joint and the foot.

**Sickles** - the long curved feathers of a male chicken's tail.

**Side Sprig** - a pointed growth on the side of a single comb.

**Slipped Wing** - a wing that is carried so that the primary feathers do not overlap properly when folded.

**Split Wing** - a wing with a distinct gap between the primary and secondary feathers, due to the permanent absence of a feather.

**Spurs** - a bony growth from the rear inner side of the shanks.

**Standard Fowl** - the large or regular-sized breeds of poultry.

**Strain** - fowl of any breed or variety that have undergone a breeding and selection program for a number of years so they reproduce with uniform characteristics.

**Stub** - a short feather, usually found on the shanks, or on or between the toes.

**Texture** - the condition or size of the grain and quality of the skin of the comb, face, wattles, and earlobes.

**Thumbprint** - a disfiguring indentation on the blade of a single comb.

**Ticking** - specks or small spots of color in contrast to the base feather color. Ticking can be required on some portions of some breeds, but it may cause disqualification in others.

---

## Leader Notes

---

**Type** - the general shape and form common to all fowl in a breed.

**Undercolor** - the color of the lower or fluff portion of feathers.

**Variety** - a subdivision of a breed, distinguished by color, color pattern, or comb type.

**Vent** - the single body opening in birds, used to both discharge the waste products of digestion and the eggs or sperm from the reproductive tract.

**Wattles** - the fleshy, red growths which hang below the side and base of the chicken's beak.

**Wry Tail** - the tail of a fowl permanently carried to one side.

### **Domestic Waterfowl and Turkey Terms**

**Bean** - a raised, hard, bean-shaped swelling on the end of the bill of waterfowl.

**Beard** - a small cluster of coarse black hairs growing from the upper part of the breast of adult male turkeys.

**Bill** - the horny mouthparts of waterfowl.

**Caruncles** - the fleshy growths of naked portions of the head and neck of the turkey and Muscovy duck.

**Dewlap** - a growth of skin hanging from under the upper bill and throat of some breeds of geese (a dewlap-like skinfold in turkeys is usually called a wattle or throat wattle).

**Drake** - a male duck.

**Duck** - name for many smaller species of the waterfowl family; also female duck.

**Duckling** - a young duck.

**Fryer-Roaster** - a young turkey usually processed at 12 to 14 weeks.

**Gander** - a male goose.

**Goose** - name for many larger species of the waterfowl family; also female goose.

**Gosling** - a young goose.

**Knob** - a knob-shaped growth at the base of the upper bill in African and Chinese breeds of geese.

**Poult** - a young turkey.

**Sex Feathers** - the feathers in the tail of male duck (except Muscovy breed) which curl upward and forward.

**Snood** - a tube-like fleshy growth near the front of the top of the head in turkeys.

**Tom** - a male turkey.

**Web** - the skin growing between the toes of waterfowl.

### **DIALOGUE FOR CRITICAL THINKING**

1. Which method of learning terms in this lesson was easiest? Hardest?
2. What method of learning do you enjoy most? Why?
3. What other activities do you do at school, home, etc., where it is important to know specific terminology?
4. What are some hobbies or careers that you feel you will have to learn a whole new set of terms to be able to understand?

### **GOING FURTHER**

1. Attend a 4-H Poultry Quiz Bowl.
2. Participate in a poultry judging contest and give oral reasons.
3. Watch a poultry judge explain placings at a poultry show.
4. Make a poster of poultry terms and share at your next 4-H club





# Poultry Breed Characteristics

*Poultry Science, Level II*

## What Members Will Learn . . .

### ABOUT THE PROJECT:

- Physical traits and characteristics associated with ten individual breeds or varieties of poultry
- Three to five breeds or varieties for each purpose (meat, egg, or dual purpose production, plus exhibition)
- Origin of ten different breeds and varieties of poultry

### ABOUT THEMSELVES:

- Differences between people with different heritage and ethnic backgrounds

### Materials Needed:

- Index cards with names of species, breeds, varieties, and place of origin
- Pictures of various species, breeds, and varieties
- Chalkboard or large piece of paper and marker to keep score
- *American Standard of Perfection* (use to get information on breeds, varieties, etc.)

**ACTIVITY TIME NEEDED:** 30 MINUTES

## ACTIVITY

## Leader Notes

---

During today's meeting we are going to practice our skills in identifying species, breeds, and varieties. We will see if we can select breeds according to their best purpose. We will also learn where some of the poultry species and breeds originated.

### CHICKENS

The domesticated chicken was derived from the Wild Jungle Fowl which still exists in a wild state in India and adjacent countries.

The *American Standard of Perfection*, which is used to judge poultry at shows, classifies purebred chickens in the following categories.

**Class**—the class a chicken belongs in is determined by the geographical area of the world in which it was developed. There are 12 classes of chickens; most of the breeds and varieties raised in the United States belong to the American, English, Mediterranean, Asiatic, or Continental classes.

**Breed**—a breed is a group of birds that possess common distinctive characteristics, such as body shape. There are 60 breeds of chickens.

## Leader Notes

**Variety**—a variety is a subdivision of a breed that differs from another variety of the same breed by comb type (single, pea, rose), feather color (white, red, buff), or feather pattern (barred, spangled, laced). An example is the Leghorn breed, which contains 12 different varieties that differ by feather color or comb type. There are 175 varieties of chickens.

Poultry is also classified by the intended use of the birds. The major **types** are:

**Egg-type** are small-bodied chickens that have been selected for maximum egg production. The Single Comb White Leghorn is the main producer of white-shelled eggs in the U.S., and the Rhode Island Red is the major producer of brown-shelled eggs.

**Meat-type** are large-bodied, fast growing, and heavily muscled chickens. The major breeds used in the production of meat-type chickens (broilers) are the White Plymouth Rock and the White Cornish.

**Dual-purpose** breeds of chickens have been bred for both egg and meat production. Examples are the Plymouth Rock, New Hampshire, Rhode Island Red, and crosses between these breeds.

**Exhibition or Fancy type** are breeds and varieties developed for show. Many of these birds are bantams, which are one-fourth to one-third smaller in size than their normal counterparts.

**Strains.** As the industry has become more specialized, emphasis has shifted from development of new breeds and varieties to improvement of strains within breeds and varieties. A strain is a flock that has been closed to new bloodlines for several generations. Many strains are named after the original developer of the strain. Most commercial egg- and meat-type stocks are strain crosses.

Relay ID Game—you can have members take turns reading off clues, or you can do this. If you have a large group, you may want to divide into several teams of two or three members. Give each player or team one point for each correct answer. Do not deduct points for incorrect answers. Some methods you may want to use in this game are: a) read breeds and variety and have members tell whether they are for meat production, dual-purpose, egg production, or exhibition, b) read purposes of poultry and have members name breeds and varieties that fit into these categories, or c) name a species of poultry and have members match breed, variety names, and place of origin.

### Characteristics of the More Common Breeds and Varieties of Chickens

Class	Skin Color	Earlobe Color	Egg shell Color	Main Use	Examples
American	Yellow	Red	Brown	Meat, egg	Plymouth Rock, New Hampshire, Rhode Island Red,
English orp	Yellow/	Red	Brown	Meat,	Cornish, Austral-
Mediterranean	White	White*	White	Egg	egg Leghorn
Asiatic	Yellow/	White	White	Egg	Leghorn
Continental	White	Red	Brown	Show	Brahma, Cochin
	White	White	White	Show	Hamburg, Polish, Houdan, Sebright

\*The Cornish has yellow skin, the Australorp white skin.

**Turkeys**

The turkey is a native of North America. Historical evidence indicates the Spanish explorers introduced the North American wild turkey into Europe. Several varieties developed from the stocks were brought to the United States by the European immigrants. These stocks have provided the genetic base for present varieties.

**Characteristics of the More Common Breeds  
and Varieties of Turkeys**

<b>Variety</b>	<b>Primary Feather Color</b>	<b>Main Use</b>
Broad-breasted Bronze	Bronze and Black	Meat, show
Large White	White	Meat
Beltsville Small White	White	Meat
Bourbon Red	Red	Show
Narragansett	Black	Show

**Ducks**

All breeds of ducks in the United States, except the Muscovy, most likely were derived from the Wild Mallard. The Muscovy is a native of South America and has a different genetic origin than the other breeds.

**Characteristics of the More Common Breeds of Ducks**

<b>Variety</b>	<b>Primary Feather Color</b>	<b>Main Use</b>
Pekin	White	Meat, show
Muscovy	White & Black varieties	Meat, show
Rouen	Multi-colored	Meat, show
Call	Various colors (varieties)	Show
Runner	Various colors	Eggs, show
Khaki Campbell	Light brown	Eggs, show

---

## Leader Notes

---

### Geese

The common breeds of geese in the United States were imported from Europe and Asia. Most of the breeds originated from the wild gray goose.

#### Characteristics of the More Common Breeds of Geese

Variety	Primary Feather Color	Main Use
Toulouse	Gray	Meat
Embden	White	Meat
African	Brown	Show
Chinese	White & brown varieties	Show, Weeders

### DIALOGUE FOR CRITICAL THINKING

1. What are the three main purposes for raising poultry?
2. What are some desirable characteristics in meat production chickens?
3. What physical characteristics do you look for when identifying breeds?
4. What are some differences between people of different origins and backgrounds?
5. What are similarities between people of different origins and backgrounds?
6. Where did your family originate?

### GOING FURTHER

1. Read about various species and breeds of poultry and trace their origin.
2. Give a talk to your club or class about the origin and characteristics of your favorite breeds of poultry.



---

# Pigeon Breeds and Varieties

*Poultry Science, Level II*

## What Members Will Learn . . .

### ABOUT THE PROJECT:

- Five breeds and varieties of pigeons
- To identify physical traits of pigeons

### ABOUT THEMSELVES:

- Symbolic uses of pigeons or doves
- Pigeon or dove phrases that are used to refer to people and which phrase best fits them

## Materials Needed:

- Large sheet of paper and marking pens
- Activity Sheet 13 - “Pigeon Parts”
- Activity Sheet 14 - “Pigeon Breeds”
- Pictures of pigeons or live pigeons
- Leader key - “Pigeon Parts”
- Leader key - “Pigeon Breeds”

**ACTIVITY TIME NEEDED:** 45 MINUTES

## ACTIVITY

Pigeons are used for the sport of racing, as flyers and performers, for showing for carrying messages, and also for meat production. The term pigeon is used to name any bird in the pigeon and dove family. The larger birds are called pigeons, and the smaller birds are called doves.

Pigeons have a plump body, a small head, and short sturdy legs. Pigeons are extremely powerful and fast flyers because they have large flight muscles in their chest. Their feathers are stiffer and smoother than those of most other birds. Pigeons vary in size. Most species measure from 10 to 15 inches long. The largest species is the crowned pigeon and it measures almost 3 feet long and weighs approximately 2 to 3 pounds. The smallest pigeon grows only about 6 inches long and weighs about 1 ounce.

Domestic pigeons are known to be the descendants of wild pigeons. The various domestic breeds and varieties we see today are a result of breeders' selection.

Pigeons have been interesting to humans throughout history. The Bible makes many references to pigeons and doves. In many cases, pigeons and doves symbolize love and peace. Pigeons may be found throughout

## Leader Notes

Ask members to list why people might raise pigeons. List their answers on the large sheet of paper.

Hand out “Pigeon Parts” and ask members to identify body parts. Show pictures or examples of different breeds or varieties of pigeons and ask members to identify them. List key identifying characteristics for each breed or variety.

---

## Leader Notes

---

Hand out member activity sheet “Pigeon Breeds” and have members match pictures of various breeds of pigeons. Use live pigeons if available

the world and have gone through many physical changes through selective breeding practices. There are now more than 200 breeds.

Characteristics that help to distinguish between breeds include size, shape, behavior, stance, feather form, colors, markings and ornamentation. Most pigeons have dull-colored feathers that are black, blue, brown, or gray. Most male and female feathers look alike, except the male feathers are a little larger and brighter in color.

### **DIALOGUE FOR CRITICAL THINKING**

1. What pigeon breeds are easiest to identify?
2. What are some reasons that people breed and raise pigeons?
3. Name some physical characteristics that would help you identify a particular breed of pigeon.
4. Why can pigeons fly faster than other domestic birds?  
(because of the large flight muscles in their chest)
5. What are some of the symbols that pigeons or doves represent?  
(peace and love)
6. How have people used pigeons?
7. What are some other symbols represented by animals?
8. What are some pigeon or dove phrases that are used to describe or refer to people?

### **GOING FURTHER**

1. Read a book about pigeons and share what you learned with your class or club.
2. Visit a museum which has a display of pigeons and compare the differences and similarities between breeds.
3. Visit a breeder of pigeons and discuss breeding practices.

**PIGEON BREEDS AND VARIETIES**  
**POULTRY SCIENCE, LEVEL II**  
**Activity Sheet 13**

**Pigeon Parts**

Write the correct word with the identified part.

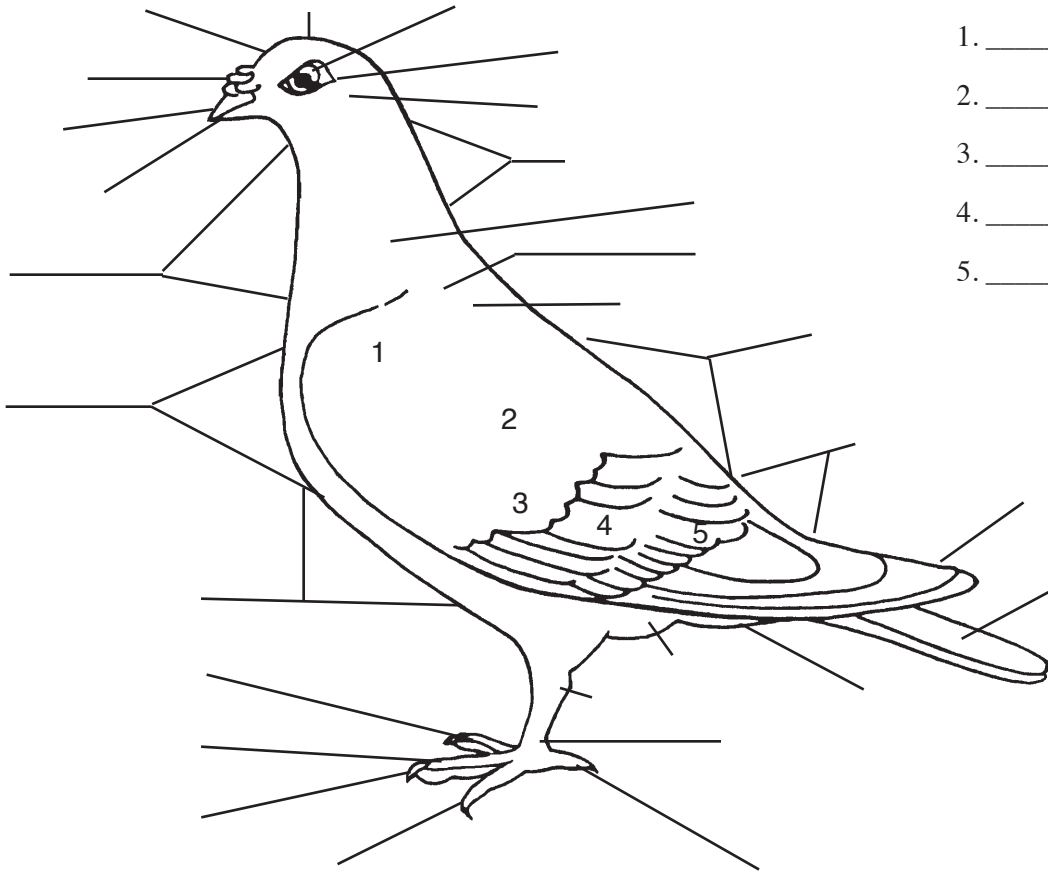

Wing Parts:

1. \_\_\_\_\_
2. \_\_\_\_\_
3. \_\_\_\_\_
4. \_\_\_\_\_
5. \_\_\_\_\_

Forehead  
 Beak-Wattle  
 Ear feathers  
 Nape  
 Shoulder  
 Breast  
 Middle toe  
 Claw  
 Outer or fourth toe  
 Wrist or wing butt  
 Middle coverts

Crown  
 Eye-core  
 Beak  
 Crop  
 Saddle  
 Inner or second toe  
 Wing flights  
 Hock  
 Hind or first toe  
 Lesser coverts  
 First wing bar

Eye  
 Nostril  
 Throat  
 Hackle  
 Back  
 Rump with upper tail coverts  
 Abdomen  
 Vent  
 Shank  
 Second wing bar  
 Main tail feathers

**PIGEON BREEDS AND VARIETIES**  
**POULTRY, LEVEL II**  
**Leader Key**

**Pigeon Parts**

Write the correct word with the identified part.

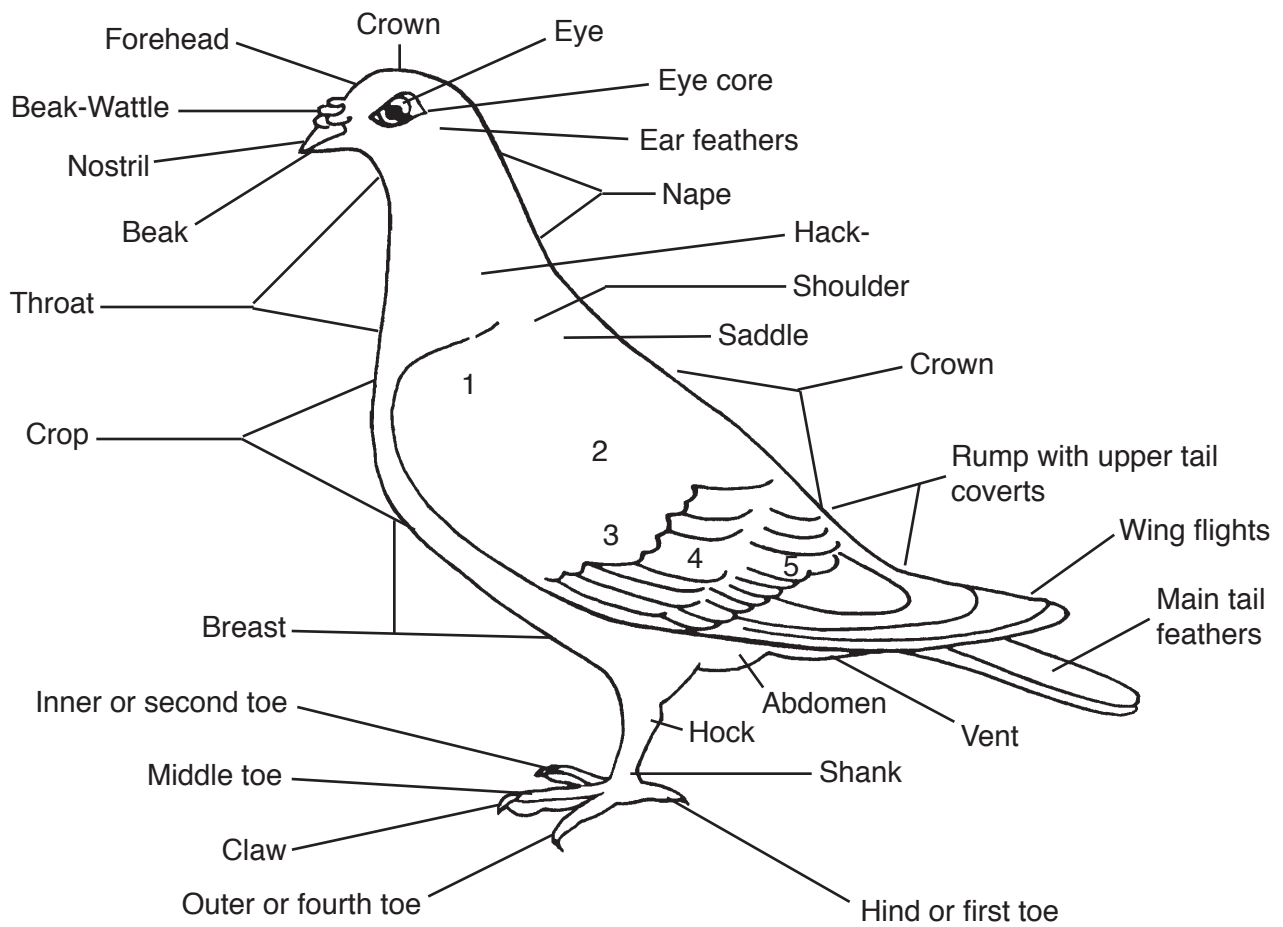

- Wing
1. Wrist or wing butt
  2. Lesser coverts
  3. Middle coverts
  4. Second wing bar
  5. First wing bar

**PIGEON BREEDS AND VARIETIES**  
**POULTRY SCIENCE, LEVEL II**  
**Activity Sheet 14**

**Identify Pigeon Breeds**

Match the name of the pigeon breed with the matching picture or diagram.

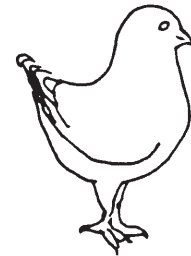
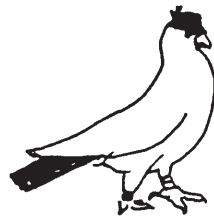

Racing Homer

Fantail

Roller

Helmet

Mondain

Jacobin

Indian Fantail

Modena

Trumpter

Swallow

King

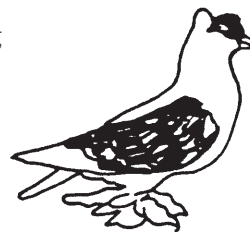
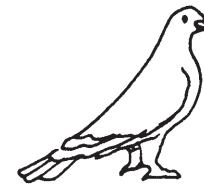
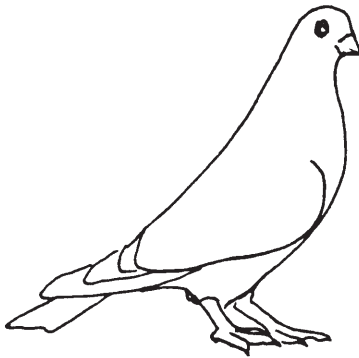

**PIGEON BREEDS AND VARIETIES**  
**POULTRY SCIENCE, LEVEL II**  
**Leader Key**

**Identify Pigeon Breeds**

Match the name of the pigeon breed with the matching picture or diagram.

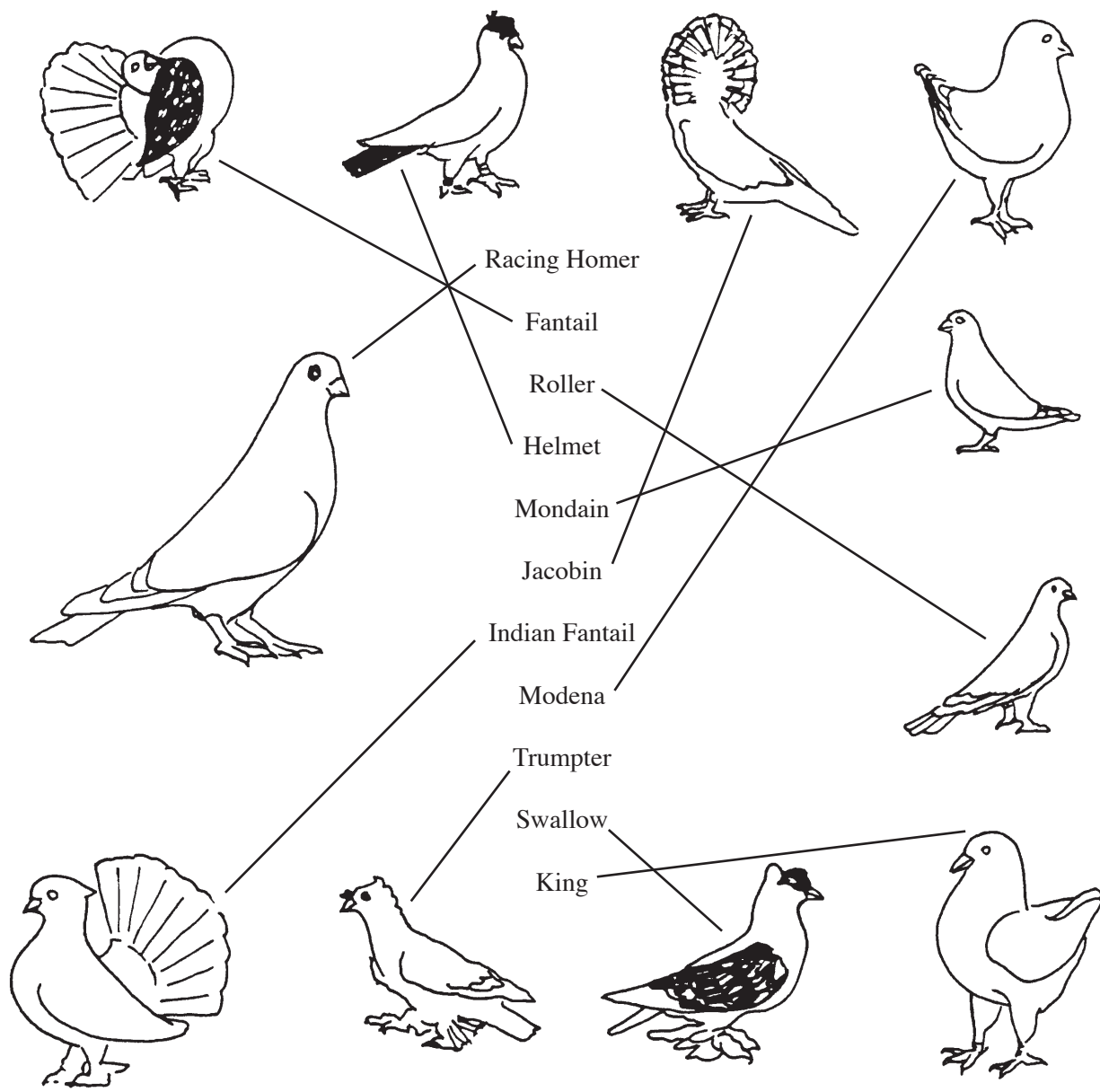



---

# Selecting Poultry for Show

*Poultry Science, Level II*

## What Members Will Learn . . .

### ABOUT THE PROJECT:

- Standards for breeds of poultry according to their purpose
- Characteristics of birds to be evaluated by the judge using the American Standard of Perfection

### ABOUT THEMSELVES:

- Personal strengths and weaknesses, and how they can improve

### Materials Needed:

- *American Standard of Perfection*
- Live birds of various qualities or bird model
- Member Handout 11 - “Poultry Disqualifications and Defects”
- Activity Sheet 15 - “Self-Evaluation”

**ACTIVITY TIME NEEDED:** 45 MINUTES

---

## ACTIVITY

As fair time approaches, start looking at your birds and choosing the best ones to exhibit. What are some of the characteristics that you would look for in a bird at the fair?

When you see another person, what are some of the things that you see? You might say color of hair, how tall they are, what kind and color of clothes they are wearing, if they are a boy or girl, whether they look happy or sad, and so on. Just as you look at another person, bird, or other animal, a judge at a poultry show will examine the bird for its physical appearance and other important characteristics.

The judge has a guideline to look for in judging a live bird, just as your teachers have guidelines when grading your papers in school. The guideline that they use is called the *American Standard of Perfection*. Inside this book is a list of all the recognized breeds and varieties of poultry and their specific characteristics.

The judge uses the *American Standard of Perfection* to identify a breed of poultry. It tells him or her what color the bird’s feathers should be, how much it should weigh, what color its beak and legs should be, what type of comb it should have, and additional descriptions.

When you select the bird to exhibit at a poultry show, you should look for a bird that comes as close as possible to meeting the description

---

## Leader Notes

Ask members to list several characteristics that they would look for in a bird. If you have a live bird, have members point to the characteristic they are describing.

Show members *American Standard of Perfection*. Select several breeds or varieties and tell what information is listed for each breed.

Have members identify what breed of bird they prefer. Talk about the description given in the *American Standard of Perfection* for that breed.

---

## Leader Notes

---

listed. You also need to examine your bird for any defects or physical features that will disqualify it from receiving an award.

When you choose a bird for show, look at the shape and appearance of its beak, comb, color of feathers, size and shape of feathers, color of earlobes, weight, etc. A bird may be disqualified from the show or top award if it does not meet the guidelines listed in the *American Standard of Perfection*.

Hand out member Activity Sheet on disqualifications and defects. Review the sheet with the members.

It's a good idea to select the birds you plan to exhibit at least 2 weeks before the show, so you have enough time to examine the birds for disqualifications or defects. You also need to pay attention to the bird's health. You don't want to exhibit a sick bird.

Look over your flock when it is gathered in the poultry house or yard and make a preliminary selection of several birds. Choose about three times as many birds as you intend to enter. Observe them carefully for 2 or 3 days before making your final choices.

### **CLASSES OF POULTRY**

Most shows such as county and state fairs will have two broad divisions: production and exhibition.

#### **Production**

Enter birds in this classification if their primary purpose is for egg or meat production. Egg-type and dual-purpose birds should be exhibited only as trios of pullets or hens. Meat-type (broilers, roasters, capons) birds should be exhibited as trios of either sex. Judging is on their production qualities only.

For egg production classes, select birds that are as uniform as possible and matched with respect to size, head type, plumage color, shank color, state of maturity, etc. Select birds of good production type, of normal size, well-feathered, free of serious physical defects (crooked beaks, deformed legs, crooked keels), and that are vigorous, healthy, and alert.

When you select pullets, choose those birds that show characteristic femininity and refinement, and sexual maturity as indicated by enlargement and redness of the comb and wattles. Pullets should be free of signs of old age. The ideal pullets to be exhibited should be near or in the early stages of egg production.

Select hens that show superior present and past egg-production as indicated by the condition of their comb, wattles, eyes, pubic bones, abdomen, and vent. Also, consider degree of bleaching and status of molt. If you are going to exhibit meat production birds, select those birds that are as uniform as possible in size, body conformation, fleshing, and finish (fat covering). Select birds that are well-feathered and free from defects, such as breast blisters and callouses, curved and crooked breast bones,

bruises, cuts and tears, and hunched backs. Fleshing and finish develop with age, so older birds will have more desirable meat qualities than younger birds.

### **Exhibition**

Standard bred (normal size) and bantam breeds of chickens, ducks, and turkeys should be entered in the young and old classes of exhibition poultry. Chickens are classified by age as follows: cock and hen—birds hatched prior to the current calendar year; or cockerel and pullet—birds hatched during the current calendar year. These birds should be pure-breds that have been selected for exhibition qualities. Exhibition birds are usually exhibited as a single male or female.

Exhibition birds should have the best body type for the breed, be uniform in color, have well-developed bodies, well-developed but not worn or ragged feathers, be healthy and free from physical defects, have the correct breed characteristics, and be free from disqualifications.

A **disqualification** is a physical defect that prevents a bird from being considered for an award. Some common general disqualifications are:

1. Crooked or crossed beak; crooked breast bone, legs or seriously crooked toes; roached or deformed back.
2. Side sprigs (extra points) on comb, split (divided) comb; comb foreign to the breed.
3. Unacceptable coloring of the earlobe, face, shanks, or feathering according to breed standards.
4. Stubs (small feathers) on legs or between toes of other than Asiatic breeds.
5. Wry tail (off to one side) and a split wing.

Hand out member Activity Sheet “Self-Evaluation.” After completion, have them discuss with a partner or a group.

### **DIALOGUE FOR CRITICAL THINKING**

1. What poultry parts do you consider when selecting the best bird of your preferred breed?
2. What are some general disqualifications?
3. What are the most difficult parts to identify on a bird?
4. How do you learn or remember poultry qualities? (Look at pictures, look at birds, make up a rhyme, etc.)
5. What do you remember most about new people you meet or new classmates?
6. What traits do you feel your friends like about you?

### **GOING FURTHER**

1. Attend a poultry show, watch and listen to a judge.
2. Participate in a poultry judging school or contest.



---

# SELECTING POULTRY FOR SHOW

## POULTRY SCIENCE, LEVEL II

### Member Handout 11

#### Poultry Disqualifications and Defects

##### Common Defects and Disqualifications

A **defect** is anything short of perfection. The cut for a defect should depend on its severity and how it compares to the severity of a defect or deformity that bars a bird from an award. This is called a **disqualification**. Following is a list of the major disqualifications by categories. Consult the *American Standard of Perfection* for a more detailed list and description.

##### Shape

Back:	crooked, roached, or deformed.
Beak:	deformed in chickens and turkeys.
Beard and muffs:	absence of beard and muffs in bearded varieties, and presence of a beard in nonbearded varieties.
Bill:	scooped or deformed in ducks and geese.
Body:	crooked keel or breast bone in all breeds of turkeys and Cornish chickens.
Comb:	one foreign to the breed or variety; a rose comb so large or lopped it obstructs the sight; absence of spike or more than one on a rose comb; a pea comb lopped below the horizontal where the bend occurs, except where this condition is a breed characteristic; a split comb with a side sprig; a cushion comb with a spike or spikes.
Crest:	absence of crest or lopped crest.
Neck:	pendulous crop in turkeys.
Plumage:	hen feathering in males of all breeds except Sebright.
Shanks and toes:	<b>all breeds</b> —bow legs; deformed foot or foot joint; duck foot in land fowl; enlarged and misshapen shank or hock; knock knee; web foot in land fowl; more or less than correct number of toes; absence of spurs in Old English and Sumatra cocks; presence or evidence of any down, stub, feather, or part of feather from shank below the hock joint, or foot or toe, on clean-legged breeds; shanks not feathered down outer sides of feather-legged breeds.
Tail:	<b>all breeds</b> —complete absence of tail feathers (except Araucanas); one or more reserve tail feathers; split tail in cock and hen; squirrel (except Japanese bantams), and wry tail.
Wings:	<b>all breeds</b> —twisted primary or secondary feather (except in Sebastapol geese and Frizzle chickens); split wings; slipped wing; one or more reversed main wing feathers; and one or more primary or secondary feathers with a split quill; clipped primary or secondary feathers in all breeds of chickens and turkeys, and all breeds of waterfowl except Canada and Egyptian geese, and Muscovy, East India, Call, and Mallard ducks; inverted wingtips in all breeds of ducks and geese.

##### Color

Bill:	black in bill or bean of white-colored drakes; more than 10 percent black in bill or bean of ducks.
Earlobes:	white in red-earlobed breeds.
Face:	white in red-earlobed breeds.
Plumage:	red or yellow in all barred, black, and mottled varieties; black in quills and primaries and secondaries, and foreign color (except slight gray ticking) in all white varieties.
Shanks and toes:	color foreign to the breed, except slight reddish in tinge of pigment in yellow shanks.

---

---

**SELECTING POULTRY FOR SHOW**  
**POULTRY SCIENCE, LEVEL II**  
**Activity Sheet 15**

**Self-Evaluation**

List your personal strengths and weaknesses and how you feel you can improve.

Strengths:

How to improve:

1. \_\_\_\_\_
2. \_\_\_\_\_
3. \_\_\_\_\_
4. \_\_\_\_\_
5. \_\_\_\_\_

- \_\_\_\_\_
- \_\_\_\_\_
- \_\_\_\_\_
- \_\_\_\_\_
- \_\_\_\_\_

Weaknesses:

How to improve:

1. \_\_\_\_\_
2. \_\_\_\_\_
3. \_\_\_\_\_
4. \_\_\_\_\_
5. \_\_\_\_\_

- \_\_\_\_\_
- \_\_\_\_\_
- \_\_\_\_\_
- \_\_\_\_\_
- \_\_\_\_\_



# Poultry Grooming

## *Poultry Science, Level II*

### What Members Will Learn . . .

#### ABOUT THE PROJECT:

- Three grooming techniques used by chickens
- The purpose for each grooming technique

#### ABOUT THEMSELVES:

- What they do to maintain personal body hygiene
- Grooming practices they do for social reasons
- Why their personal appearance is important to them

#### Materials Needed:

- Small farm flock
- Pencil and writing pad
- Activity Sheet 16 - “Observing Poultry Grooming Habits” for each member

**ACTIVITY TIME NEEDED:** 45 MINUTES

### ACTIVITY

### Leader Notes

---

Animals groom themselves, as we do, except in different ways. The object of their grooming is much the same as ours, to clean themselves and make them attractive to others of their species.

There are three basic types of grooming by birds. **Dust bathing** is practiced by birds that are allowed on the ground. It involves the birds resting on an area where the soil is dusty. By fluffing their feathers, dust particles are spread over their body surfaces. This process has both a soothing effect, and in some cases, is useful in controlling external parasites such as lice. **Preening** involves the bird using its beak or bill to spread oil secreted by the oil gland (located on top of the tail) onto the feathers. The oil maintains the luster of the feathers and improves the water resistance of the feathers. **Feather pecking** can be either a grooming activity or a cannibalistic activity. Feather pecking is a grooming activity when a bird pecks or grooms the feathers of penmates. In contrast, feather pecking becomes a cannibalistic activity when damage is done to the skin or feathers of the bird that is being pecked.

Observe a group of birds in an area where they can be viewed and not disturbed. This could be a loafing pen or run attached to a building. Sit and watch the birds. What activities are observed? Make a list on the activity sheet of each grooming activity and what its function/reason might be.

### DIALOGUE FOR CRITICAL THINKING

1. How did the birds clean themselves?
2. When birds pecked at the top of the tail, what were they doing?

---

## Leader Notes

---

3. When birds sit in the dust and shake their feathers, they are taking a dust bath. This helps to remove external parasites, and fluff up the feathers. How does our taking a bath serve a similar function?
4. Did you notice birds running their beaks through their feathers? How is that like combing our hair?
5. Why is it necessary for birds and humans to maintain a clean body?
6. What are the social reasons for keeping ourselves clean?
7. What styles of grooming are socially accepted, but are not related to health?
8. Why is appearance important to chickens and humans?

### **GOING FURTHER**

1. Read a book on poultry behavior.
2. View a video or movie on some aspect of poultry behavior.







# Poultry Showmanship

## *Poultry Science, Level II*

### What Members Will Learn . . .

#### **ABOUT THE PROJECT:**

- Five parts of a bird examined during a show
- Characteristics defining quality and condition of a bird
- How to take waterfowl from a cage

#### **ABOUT THEMSELVES:**

- How they feel about presenting themselves for examinations
- How they feel about the impressions they make with friends and others

#### **Materials Needed:**

- Tables and cages
- Live bird
- Wood shavings
- Paper to cover table
- A judge
- Member Handout 12 - "Poultry Handling Positions"

**ACTIVITY TIME NEEDED:** 45 MINUTES

### **ACTIVITY**

Most showmanship events involve demonstrating these procedures when requested by the judge.

#### **HOLDING AND CARRYING THE BIRD**

To carry a bird, keep the body balanced and upright on the palm of the same hand that you used to remove the bird from the cage. The head and neck may extend between the arm and body of the person carrying it or, with a small bird, against the carrier's body and above the arm on which it is carried. The other hand should rest on the bird's back.

#### **EXAMINATION AND HANDLING**

Hold birds upright to give the judge a side view of the body. The bird should rest comfortably on the palm of the holder's hand. The strengths of the bird should be emphasized: tails fluffed, head and beak raised, feathers smoothed, wings tucked in normal position. In this basic hand-posed position, the 4-H participants will be asked to show the judge several parts of the bird.

**Head** - Raise the bird to shoulder height and turn it so that the head and face can be examined. The hand supporting the bird should remain in

### **Leader Notes**

Set up a practice contest with a 4-H'er as judge and a team of two members to show a bird. After the members have attempted to perform each task, ask each pair to demonstrate one of the tasks for the entire group.

---

## Leader Notes

---

place, while the free hand moves the head. Complete the examination by turning the bird to examine the other side of the head and face.

**Wings** - Spread wings to examine condition and pattern of the feathers. To extend the first wing, grasp wing tip with free hand and pull. To examine second wing, place free hand across body of bird and apply pressure to last wing joint with thumb and fingers of free hand to extend the wing.

**Undercolor** - The undercolor of the back and body fluff of the birds will be examined. Use finger tips to gently pull tops of feathers “against the grain.” This action exposes portions of feathers normally hidden from view.

**Width of Body** - Width of body is determined by placing the thumb and index fingers of free hand across the bird’s body directly behind the bases of the wings. Gently push the measuring arch, thus formed downward to the tail, to determine the width and shape of the body.

**Breast** - Without changing the grip, examine the breast by holding the bird so that its head is downward and its back is directly against your body. Use your free hand to measure the breast bone and examine the keel for straightness, breast blisters, indentations, or other defects. In this position the depth of the body or distance between the keel and back may also be determined.

**Depth of Abdomen** - After examining the vent, measure the depth of the abdomen by placing as many fingers of the free hand as possible between the tip of the keel and the pubic bones.

**Pubic Bones** - The width between the pubic bones is determined by placing as many fingers of the free hand as possible between the tips of these bones.

**Feet and Legs** - To examine the feet and legs, hold the bird against the your body. The free hand should be used to manipulate feet and legs so all parts can be examined. Swivel the bird to examine the front of the feet and legs.

### **4-H’ER’S PERSONAL APPEARANCE**

Each contestant should be neatly dressed in clean, well-pressed clothes. No uniform is required, but no shorts or cut-offs should be worn. Personal grooming is particularly important.

### **QUALITY AND CONDITION OF BIRD**

When selecting a bird, whether it’s a male or female, large fowl bird, a bantam, a duck, a goose, or a turkey, the following characteristics should be considered:

- Pleasing appearance—bright eyes, good fleshing, free from defects

- Good, smooth plumage—shiny appearance, clean and washed if appropriate for species
- Breed and varietal characteristics
- Free from diseases and parasites
- Gentle and not flighty—usually a bird that is worked with over a period of time will become accustomed to the showmanship routine and will show its strongest characteristics while being judged. A radio played near the bird will also help familiarize it with show conditions. A short practice session just before the contest is also suggested to help calm both bird and exhibitor.

### **KNOWLEDGE OF POULTRY TERMS**

The judge will ask the participants to explain various poultry terms and their relationship to the bird and the poultry project.

### **TURKEY AND WATERFOWL SHOWMANSHIP HINTS**

Turkey and waterfowl are shown in almost the same way as chickens. The only major difference occurs when waterfowl are taken out of the cage. The correct procedure is as follows:

Open cage door. Grasp large duck's or goose's neck (loosely) and turn bird toward cage door. Pull out of cage, head first. At the same time slide second hand beneath the bird's body, place fingers between the bird's legs and grasp them so the bird, when lifted, can be balanced on the palm of that hand. Place first hand on bird's back and wings.

All other procedures will be the same as for chickens. When taking out very small ducks, such as bantam ducks, the same procedure as for chickens may be used. Ducks or geese should never be caught by the legs.

### **DIALOGUE FOR CRITICAL THINKING**

1. Name five of the eight parts of a bird to be examined during a show.
2. What was the most difficult position to hold and present your bird to the judge?
3. When have you had to present yourself for inspection or examination? How did it feel?
4. How will showing birds prepare you to show your best qualities in the classroom, to other friends, or to parents?

---

---

**POULTRY SHOWMANSHIP**  
**POULTRY SCIENCE, LEVEL II**  
**Handout 12**

**Poultry Handling Positions**



Carrying



Holding



Head Examination



Wing Examination



Under color

---

---

**POULTRY SHOWMANSHIP**  
**POULTRY SCIENCE, LEVEL II**  
**Handout 12 (continued)**

**Poultry Handling Positions (continued)**

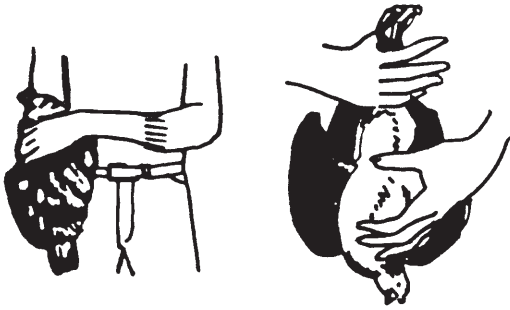

Width of Body and Breast

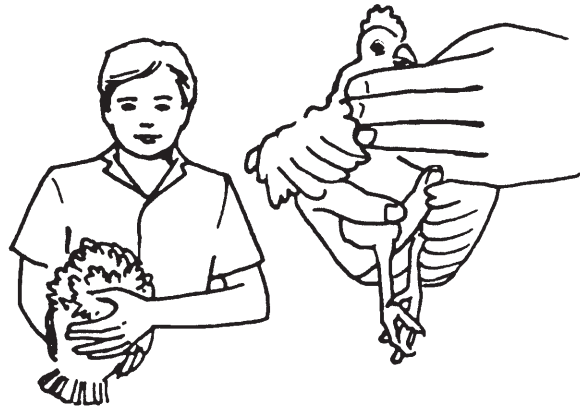

Depth of Abdomen

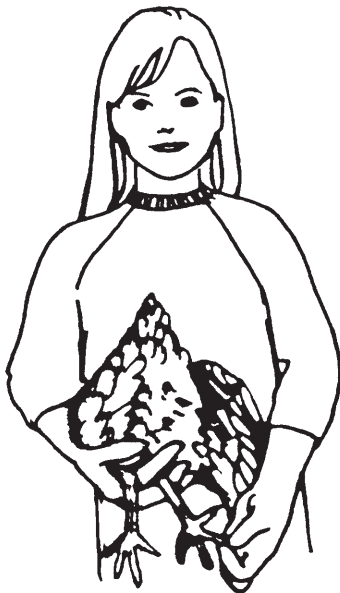

Feet and Legs



Pubic Bones





# Basic Egg Cookery

*Poultry Science, Level II*

## What Members Will Learn . . .

### ABOUT THE PROJECT:

- The nutritional value of eggs
- The functional properties that eggs contribute to our food
- Various methods of cooking eggs
- Proper egg handling and care

### ABOUT THEMSELVES:

- How important they believe eggs are in their diet
- How they feel about the functional properties of eggs
- To what extent they think they will use eggs in the future

### Materials Needed:

- Eggs
- Ingredients and cooking equipment required for the recipe(s) that will be used
- Member Handout 13 - “Nutrient Density of the Egg”
- “Kids in the Kitchen” and “Basic Egg Cookery” from the Kansas Poultry Association
- Activity Sheet 17 - “Egg Dish and Properties Word Match”
- Leader Key - “Egg Dish and Properties Word Match”

**ACTIVITY TIME REQUIRED:** 60 MINUTES

## ACTIVITY

## Leader Notes

---

Eggs are hard to beat for easy preparation, great versatility, and delicious eating. Eggs are also one of nature’s most nourishing foods, since they contain a wide array of necessary nutrients that both chicks and humans need.

Egg protein is of such high quality that it is often used as the standard by which other protein is measured. Egg protein contains all of the essential amino acids (building blocks of protein which the body needs but cannot make) in a pattern that closely matches the pattern the body needs. That is why eggs are classified with meat in the basic food groups and why egg protein is called a complete protein.

Foods that supply significant amounts of one or more nutrients compared to the number of calories they supply are called nutrient dense. Eggs have a high nutrient density because they provide excellent protein and a wide range of vitamins and minerals in proportion to their calorie count. For example, one large egg provides 15 percent of the U.S. Recom-

Ask members to name the six food groups in the Food Guide Pyramid and indicate which group eggs belong in. For more information refer to the publication, *4-H Leader Guide to the Food Guide Pyramid*, MI/4H 1519.

---

## Leader Notes

---

Hand out table showing nutritional density of an egg.

Let members try to identify these functional properties or uses.

Give each member the activity sheet “Egg Dish and Properties Word Match” as a review.

Have groups of members prepare eggs using different methods. Identify the functional property with each method of cooking.

mended Daily Allowance for protein; equals one ounce of lean meat, fish, or poultry; contains varying amounts of vitamins (but no vitamin C) and minerals; and contains only 80 calories. An egg yolk is one of the few foods which contain vitamin D, the sunshine vitamin.

In addition to nutritional qualities, eggs are used in cooking because of their varied functional properties. Examples of an egg’s functional properties are:

1. **Foaming or leavening** - air bubbles are trapped in liquid egg white when it is beaten. The beaten white becomes foamy, increases six to eight times in volume, and stands in peaks. When the foam is heated, the tiny air cells expand and the egg protein coagulates around them, giving permanence to the foam. Egg white foam is responsible for the structure of souffles, angel food cakes, puffy omelets, and meringue. Fat inhibits the foaming of egg white, so be sure beaters and bowls are clean and that there is not a trace of yolk in the whites.
2. **Thickening** - when eggs are added to pumpkin pies, custards, and sauces, heating coagulates the protein, causing the mixture to become thicker.
3. **Coating** - eggs are added to batters in which meat, French toast, and vegetables are dipped prior to deep fat frying. The egg increases the ability of the batter to stick to the food.
4. **Emulsification** - a component in an egg, called lecithin, helps to stabilize emulsions or mixtures of liquids, such as mayonnaise, salad dressings, and Hollandaise sauce, so that the various ingredients do not separate.
5. **Garnishing** - eggs can be hard cooked and used as a garnish on salads.

There are **five basic methods for cooking eggs**: **baked** (also known as shirred); **cooked in the shell** (eggs in their shells cooked in water) either hard-cooked or soft-cooked; **fried**; **poached** (eggs cooked out of the shell in hot water, milk, broth, or liquid); and **scrambled**.

The basic principle of egg cooking is to use a medium to low temperature and time carefully. When eggs are cooked at too high a temperature, whites shrink and become tough and rubbery; yolks become tough, and their surface may turn gray-green. Eggs other than hard-cooked should be cooked until the whites are completely coagulated and the yolks start to thicken.

Before you start to cook:

- Wash your hands!
- Wear an apron.
- Read the recipe and get the food and utensils you will need.
- Use only microwave-safe dishes when you cook in the microwave.
- When you uncover a hot pan or dish, lift the back edge of the lid or plastic wrap first so the steam won't burn you.
- Use pot holders to move hot pans or dishes.
- Don't forget to clean up!

The same nutrient qualities that make eggs a high-quality food for humans can also be a good growth medium for bacteria that cause food poisoning. In addition to food, bacteria also need moisture, a favorable temperature (between 40° and 140°F), and time to multiply. By using good hygiene, refrigeration, cooking, and handling practices, you can ensure that your eggs will maintain their high quality and safety for use in dozens of ways.

### **DIALOGUE FOR CRITICAL THINKING**

1. What functional properties of eggs surprised you the most?
2. Which functional property of eggs do you use or enjoy the most? Why?
3. When using the five basic cooking methods, which was the easiest? The most difficult? Why?
4. Discuss or explain your favorite use of eggs.
5. How important do you feel eggs are in your diet?
6. Discuss the important factors of food safety when storing eggs.
7. Discuss the ease of cooking eggs as compared to other foods that are important in a basic daily diet.

### **GOING FURTHER**

1. Discuss the issue of fats and cholesterol as it relates to eggs.
2. Prepare a talk or demonstration about eggs to share with classmates or other audiences.
3. Visit a restaurant to see how eggs are used or to determine the most popular uses.

---

---

**BASIC EGG COOKERY**  
**POULTRY SCIENCE, LEVEL II**  
**Handout 13**

**Nutrient Density of the Egg**  
Percentage of US Recommended Daily Allowances (US RDA)  
provided by 1 large egg

PROTEIN .....	15%
VITAMIN A.....	6%
VITAMIN C.....	LESS THAN 2%
THIAMIN .....	2%
RIBOFLAVIN.....	15%
NIACIN .....	LESS THAN 2%
CALCIUM .....	2%
IRON.....	4%
VITAMIN D .....	6%
VITAMIN E.....	2%
VITAMIN B6.....	4%
FOLIC ACID .....	6%
VITAMIN B12.....	8%
PHOSPHORUS .....	8%
IODINE.....	15%
MAGNESIUM.....	LESS THAN 2%
ZINC .....	4%
COPPER .....	LESS THAN 3%
BIOTIN .....	4%
PANTOTHENIC ACID .....	6%

80 CALORIES (4% OF DAILY INTAKE ON AN 1800-CALORIE DIET)

5 GRAMS OF FAT (1 GRAM POLYUNSATURATED, 2 SATURATED, 2 MONOUNSATURATED)

---

---

**BASIC EGG COOKERY**  
**POULTRY SCIENCE, LEVEL II**  
**Activity Sheet 17**

**Egg Dish and Properties Word Match**

Match the functional properties of eggs with the correct egg dish. Match all that apply.

**Functional Property**

**Egg Dish**

Emulsification

Meringue

Foaming

Angel food cake

Thickening

Pumpkin pie

Garnish

Custard

Coating

Souffle

Meat batter

Mayonnaise

Salads

---

---

**BASIC EGG COOKERY**  
**POULTRY SCIENCE, LEVEL II**  
**Leader Key**

**Egg Dish and Properties Word Match**

Match the functional properties of eggs with the correct egg dish. Match all that apply.

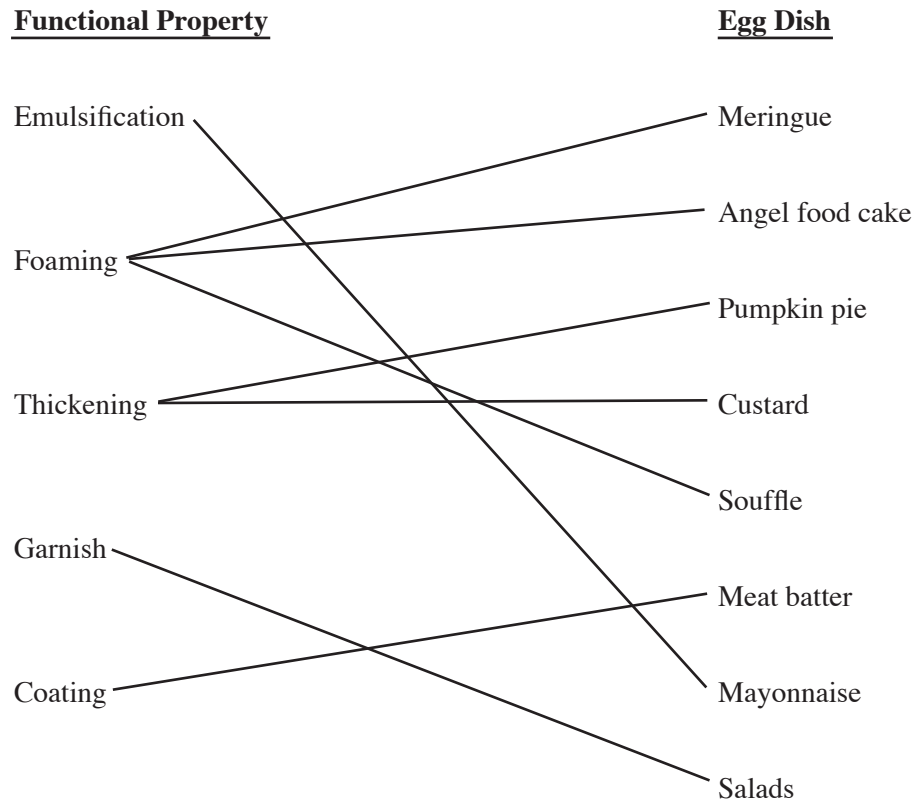



# Ethnic Recipes for Omelets

*Poultry Science, Level II*

## What Members Will Learn . . .

### ABOUT THE PROJECT:

- How to read and follow a recipe
- To observe and demonstrate how to make a two-egg omelet
- To learn about the nutritional value of an egg
- To compare the differences between high and low quality omelets and scrambled eggs

### ABOUT THEMSELVES:

- Their feelings about other cultures and ethnic groups related to omelet fillings
- Their attitude toward the nutritional value of eggs

### Materials Needed:

- Eggs
- Cooking utensils required for preparing omelets
- Recipes for various types of omelets
- A good appetite
- Member Handout 14 - “Omelets”

**ACTIVITY TIME NEEDED:** 45 MINUTES

## ACTIVITY

## Leader Notes

---

Whether you prefer the French spelling “omelett” or the all-American “omelet,” an omelet is easy to make. It’s strictly beaten eggs cooked in a pan, then rolled or folded—usually around a filling, and, sometimes, with a topping. Since the filling can be almost anything you like, an omelet is one of the most versatile dishes in a cook’s recipe collection.

The ancient Romans supposedly made the first omelet, and, because it was sweetened with honey, called it omemele (egg and honey). Some insist this was the origin of the word *omelet*. Others maintain the word was derived from omelett (French) meaning blade, describing the long, flat shape of an omelet.

Whatever its origin, an omelet can hold or be topped with any food from caviar to leftover meatloaf, vegetables, etc. The possibilities of fillings and toppings are only limited by your imagination and the contents of your refrigerator. In fact, the main difference between omelets in different cultures is the fillings that are used.

An omelet can be a down-home main dish served on everyday stoneware, or it can be filled with fancy foods from the gourmet section and

---

## Leader Notes

---

served on china. For any meal of the day, an omelet is easy to adapt to suit your taste, timetable, and budget. The three basic omelets are the French omelet (plain), the basic French (plain) microwave omelet, and the basic puffy (souffle) omelet.

Omelets are easy and quick to prepare and are very economical. A plain omelet takes only about one to two minutes to prepare on top of the range. Or, if you like, use the microwave for the added convenience of no-stir cooking. If a dozen large eggs costs 90 cents a dozen or 60 cents a pound, the egg in a two-egg omelet costs 15 cents.

Have members break into groups of two or three and select and prepare an omelet.

Give members the “Omelet” handout illustrating the steps in making an omelet.

Using the table showing the nutritional content of eggs, have members calculate the grams of protein and calories that a two-egg omelet contains.

### **Making an Omelet Is Easy—Follow These Simple Steps**

- Cooking an omelet requires very little equipment: an 8- to 10-inch diameter no-stick pan, a mixing bowl, an egg whip, a plastic spatula, and a serving dish.
- Prepare the fillings before starting to cook the eggs. Heat refrigerator-cold ingredients to serving temperature or fully cook raw foods before you begin cooking the omelet.
- Use 1 tablespoon of water for each egg. Water is recommended for omelets because the high heat used in cooking omelets will break down the protein in milk resulting in a “flat” texture rather than the desired fluffiness.” Use water for omelet, milk for scrambled eggs. Beat eggs, water, salt, and pepper until blended.
- Heat the omelet pan over medium-high heat until pan is hot enough to sizzle a drop of water. Add a pat of butter or teaspoon of vegetable oil to the pan. Pour in egg mixture.
- With an inverted spatula or pancake turner, carefully push cooked portions at edges toward center of pan so uncooked portions can reach hot surface at edge of pan. Tilt pan and move cooked portions as necessary.
- While the top is still moist and creamy-looking, but not runny, fill the omelet (on left side if right handed, vice versa if left handed).
- After filling omelet, fold in half or roll with spatula. Invert (flip over) omelet onto plate with a quick flip of the wrist or slide from pan onto plate. Flipping omelet over hides those “tears” that may occur when you fold the omelet over.

**Proper care and handling of eggs** and egg dishes is very important to prevent food infections. Follow these steps to assure proper care and handling:

1. Hold eggs or egg dishes below 45°F or above 140°F.
2. Wash hands before preparing omelets.
3. Use only clean, uncracked eggs.
4. Use clean, sanitized utensils and equipment.

5. Cook omelet thoroughly.
6. Never leave egg dishes at room temperature more than 1 hour.

### **DIALOGUE FOR CRITICAL THINKING**

1. How did you feel about making an omelet?
2. Discuss the differences between omelets and scrambled eggs.
3. What problems did you have when making an omelet?
4. What types of fillings do you prefer?
5. What do you think was the most unusual filling that someone tried?
6. What cultures or ethnic groups did you study because of certain types of fillings?
7. Discuss the nutritional value of eggs.
8. How do you feel about cholesterol in your diet?

### **GOING FURTHER**

1. Demonstrate how to make an omelet before your club.
2. Prepare different types of omelets using different fillings.
3. Prepare a flaming dessert omelet.
4. Organize and hold an “omelet” party for a special event of your club or as a fund raising project.

**ETHNIC RECIPES FOR OMELETS**  
**POULTRY SCIENCE, LEVEL II**  
**Handout 14**

**Omelets**

**NUTRITION INFORMATION PER SERVING**

1 Large Egg (50g edible portion)

Calories .....	80
Protein .....	6 g
Carbohydrates less than .....	1 g
Fat (Percent of Calories - 56%) .....	5 g
Polyunsaturated .....	1 g
Saturated .....	2 g
Monounsaturated .....	2 g
Cholesterol .....	.215 mg
Sodium .....	.65 mg

**Percentage of U.S. Recommended  
Daily Allowances (U.S. RDA)**

Protein .....	15	Vitamin B6.....	4
Vitamin A .....	6	Folic Acid .....	6
Vitamin C .....	*	Vitamin B12.....	8
Thiamin .....	2	Phosphorus.....	8
Riboflavin.....	15	Iodine .....	15
Niacin.....	*	Magnesium .....	*
Calcium .....	2	Zinc .....	4
Iron .....	4	Copper .....	*
Vitamin D.....	6	Biotin .....	4
Vitamin E .....	2	Pantothenic Acid.....	6

\*Contains less than 2% of the U.S. RDA of these nutrients

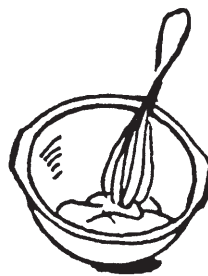

Beat

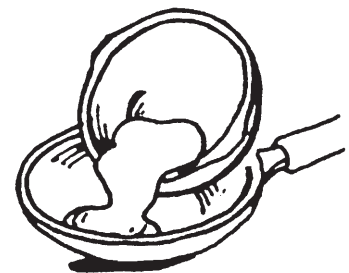

Pour

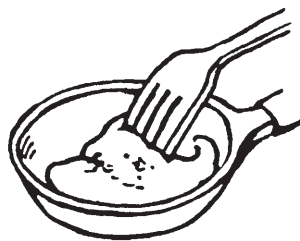

Push



Tilt



Fill



Serve



# The Diet Balancing Act with Poultry Products

*Poultry Science, Level II*

## What Members Will Learn . . .

### ABOUT THE PROJECT:

- The food guide pyramid and its role in human nutrition
- The nutrients found in the food pyramid
- To identify examples of foods that provide these nutrients
- To identify the role of poultry products in a balanced diet

### ABOUT THEMSELVES:

- The adequacy of their diet
- What adjustments are needed in their food habits
- How important a proper diet is to them

## Materials Needed:

- Handout 15 - "Food-Nutrient Check-off"
- Handout 16 - "Food Guide Pyramid"
- Handout 17 - "Nutritive Value of Selected Foods"
- Handout 18 - "Recommended Daily Dietary Allowances (RDA) for Humans"

**ACTIVITY TIME NEEDED:** 45 MINUTES

## ACTIVITY

## Leader Notes

Food alone cannot make you healthy. But, healthful eating habits, which include moderation and a variety of foods, can help. Many American diets have too many calories and too much fat, cholesterol, and sodium, and too little complex carbohydrates and fiber.

These six dietary guidelines are recommended for good health.

**1. Eat a variety of foods.** Because no one food contains all the nutrients, it is necessary to eat a variety of foods within the food pyramid—dairy products, fruits, vegetables, grains, and meat/eggs.

Hand out the "Food Guide Pyramid." Have members list examples of foods for each section.

Food Group	Major Contribution to Diet
Dairy products	Protein, vitamins A & D, riboflavin, calcium, phosphorus
Fruits	Fiber, vitamins A & C, minerals, folic acid
Vegetables	Fiber, vitamins A & C, various minerals
Grains	Protein, carbohydrates, fiber, iron, B-complex vitamins
Meat and eggs	Protein, B-complex vitamins, iron, zinc

Use the handout showing the nutritive value of foods. Prepare a visual showing the major nutrients that eggs and chicken contribute to the diet.

---

## Leader Notes

---

Eggs and poultry are part of the meat group. Roasted, skinless poultry meat has less fat (calories) and cholesterol than other meats.

**2. Maintain a healthy weight.** What weight is right for you? There is no definite answer to this question because youth come in all sizes and shapes. Children need energy to grow and develop normally. Overweight or underweight children may need help in choosing nutritious diets.

**3. Choose a diet low in fat, saturated fat, and cholesterol.** Eating less fat makes sense because fat is linked with being overweight. A diet high in fat gives more energy than you need, but often less of other nutrients. Skinless poultry meat and eggs are high in protein and low in fat.

**4. Choose a diet with plenty of vegetables, fruits, and grain products.** These foods are especially important for their starches and fiber, and are generally low in fat.

Many egg dishes combine a variety of different foods, including those high in starch and fiber. For example, omelets and souffles can use foods from the meat, milk, fruit, and vegetable groups. Quiches can use foods from all these groups, including the grain (bread) group.

**5. Use sugars only in moderation.** Sugars are widespread in nature, occurring in fruits, vegetables, honey, legumes, grains, and milk. Table sugar and sugar from corn syrups provide most of the sugar in the average diet. Many snack foods and beverages that are high in sugar have a low protein, vitamin, and mineral content.

Sugar and starch (which breaks down into sugar) are sources of energy, but contain few other nutrients. Eating foods that contain large amounts of sugar and starch should be avoided because they may keep you from eating more nutritious foods, and can contribute to tooth decay and being overweight. Desserts containing eggs as the main ingredient are relatively low in sugar.

**6. Use salt in moderation.** Salt is essential in the diet. However, most Americans consume more salt than they need. Snack foods, such as chips, crackers, pretzels, and nuts, are high in salt. Unsalted eggs and poultry meat are naturally low in salt.

### DIALOGUE FOR CRITICAL THINKING

1. Name five of the six dietary guidelines suggested in this lesson.
2. Which guideline do you disregard the most? Why?
3. What dietary problems do you have? Why?
4. What basic food group do you have the most trouble including in your diet?
5. What things, besides the food you eat, influence your health?

### GOING FURTHER

1. Keep a record for several days of the types of foods that you eat. Are you getting a well-balanced diet?

Use nutritive value of foods handout to show members the nutritive composition of popular foods such as soft drinks, potato chips, etc. Compare these to the eggs and chicken handout used earlier.

Conclude the lesson by having members complete Handout 15, "Food and Nutrient Check-off."

---

---

**THE DIET BALANCING ACT WITH POULTRY PRODUCTS**  
**POULTRY SCIENCE, LEVEL II**  
**Handout 15**

**Food Nutrient Check-off**

<b>Nutrient</b>	<b>Chicken</b>	<b>Eggs</b>	<b>Fruits and Vegetables</b>	<b>Dairy Products</b>	<b>Grains</b>
<b>B-Vitamins</b>					
<b>Carbohydrates</b>					
<b>Calcium</b>					
<b>Protein</b>					
<b>Iron</b>					
<b>Vitamin A</b>					
<b>Vitamin C</b>					

Under each food item, check the major nutrients it supplies to your diet.

**THE DIET BALANCING ACT WITH POULTRY PRODUCTS**  
**POULTRY SCIENCE, LEVEL II**  
**Handout 16**

# Food Guide Pyramid

## A Guide to Daily Food Choices

Food Guide Pyramid

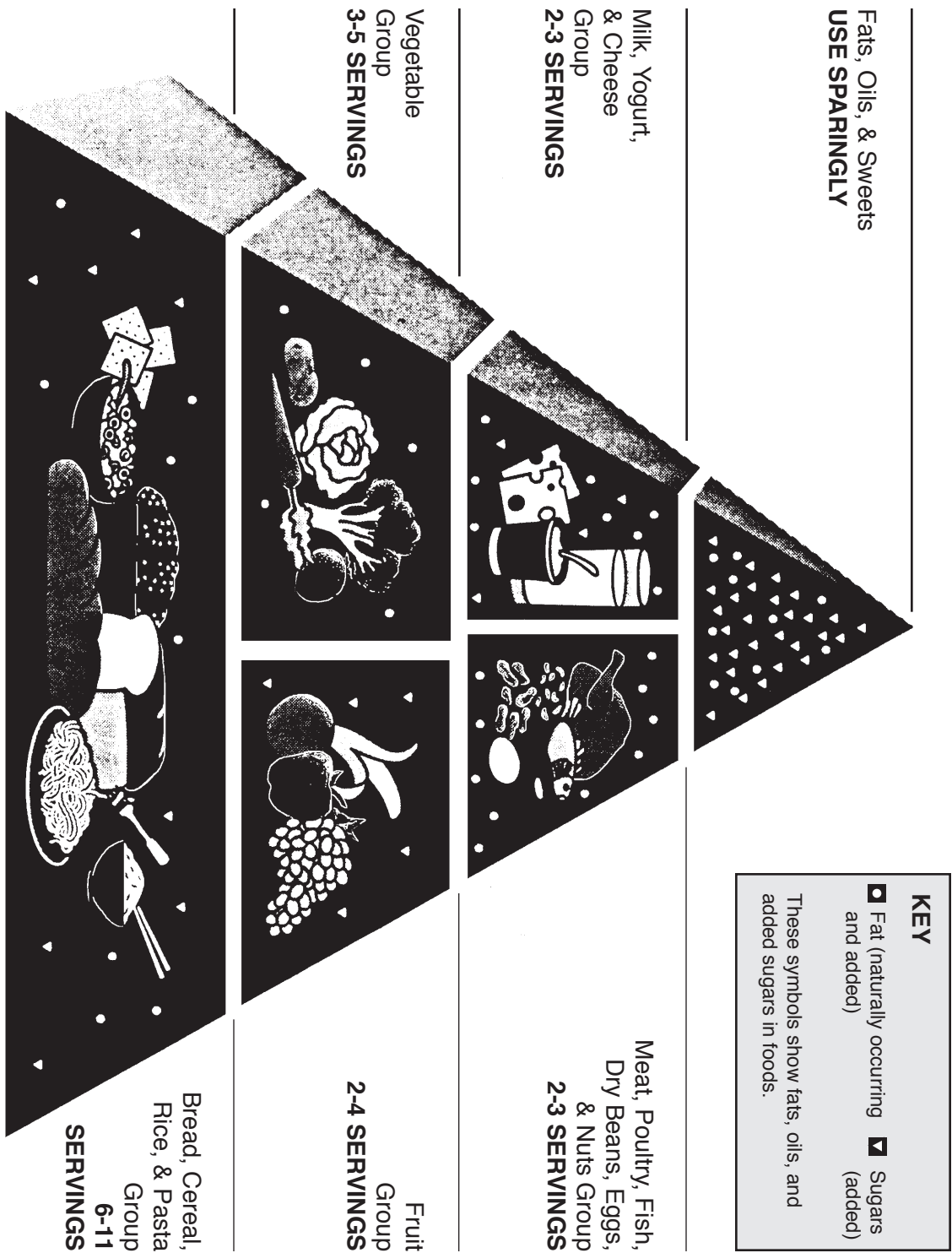

**THE DIET BALANCING ACT WITH POULTRY PRODUCTS**  
**POULTRY SCIENCE, LEVEL II**  
**Handout 17**

**Nutritive Value of Selected Foods**

Food	Energy Cal	Protein Grams	Fat Grams	Ca MG	P MG	Iron MG	Sodium MG	Vit A IU	Thiamin MG	Riboflavin MG	Ascorbic Acid	
											MG	MG
Reg Cola (12 oz)	160	0	0	11	52	.2	18	0	0	0	0	0
Milk, 2% (1 cup)	120	8	5	297	232	.1	122	500	.10	.40	.2	2
Ice Milk, 4% (1 c)	185	5	6	176	129	.2	105	210	.08	.35	.1	1
Egg, lg, fried	95	6	7	29	91	1.1	162	320	.04	.14	Trace	0
Fishstick (4"x1"x 1/2")	70	6	3	11	58	.3	53	20	.03	.05	.6	0
Apple, raw (2 3/4" diam)	80	Trace	Trace	10	10	.2	Trace	70	.02	.02	.1	8
Orange, raw (1 cup)	85	2	Trace	72	25	.2	Trace	370	.16	.07	.5	96
Bread, wheat (1 slice)	65	2	1	32	47	.9	138	Trace	.12	.08	1.2	Trace
Oatmeal, (1 cup)	145	6	2	19	178	1.6	2	40	.26	.05	.3	0
Cheerios (1 1/4 cup)	110	4	2	48	134	4.5	307	1250	.37	.43	5.0	15
Lucky Charms (1 cup)	110	3	1	32	79	4.5	201	1250	.37	.43	5.0	15
Donut, glazed (1)	235	4	13	17	55	1.4	222	Trace	.28	.12	1.8	0
Peanuts, salted (1 cup)	840	39	71	125	734	2.8	626	0	.42	.15	21.5	0
Hamburger (4 oz)	445	25	21	75	225	4.8	763	160	.38	.38	7.8	1
Chicken breast, fried (3.5 oz)	220	31	9	16	228	1.2	74	50	.08	.13	13.5	0
Candy, milk choc (1 oz)	145	2	9	50	61	.4	23	30	.02	.10	.1	Trace
Green beans (1 cup)	25	2	Trace	35	26	1.2	339	470	.02	.08	.3	6
Carrot, raw (1)	30	1	Trace	19	32	.4	25	20,250	.07	.04	.7	7
Corn, canned (1 cup)	165	5	1	11	134	.9	571	510	.09	.15	2.5	17
Potato chips (10)	105	1	7	5	31	.2	94	0	.03	Trace	.8	8

Source: Nutritive Value of Foods, USDA, Home and Garden Bulletin, Number 72, Revised 1981

# THE DIET BALANCING ACT WITH POULTRY PRODUCTS

## POULTRY SCIENCE, LEVEL II

### Handout 18

#### Recommended Daily Dietary Allowances (RDA) for Humans

(Designed for the maintenance of good nutrition of practically all healthy persons in the United States.)

Sex-age category	Persons						Food energy	Protein	Minerals			Vitamin A	Thia-min	Ribo-flavin	Nia-cin	Ascor-bic acid	
	Age	Weight		Height		Cal-cium			Phos-phorus	Iron							
	Years From	To	Kilo-grams	Pounds	Centi-meters	Inches	Calories	Grams	Milli-grams	Milli-grams	Milli-grams	Retinol equivalents <sup>2</sup>	Interna-tional units <sup>3</sup>	Milli-grams	Milli-grams	Milli-grams	Milli-grams
Infants	0	0.5	6	13	60	24	kg x 115 lb x 52.3	kg x 2.2 lb x 1.0	360	240	10	420	1,400	0.3	0.4	6	35
	0.5	1	9	20	71	28	kg x 105 lb x 47.7	kg x 2.0 lb x 0.9	540	360	15	400	2,000	0.5	0.6	8	35
Children	1	3	13	29	90	35	1,300	23	800	800	15	400	2,000	0.7	0.8	9	45
	4	6	20	44	112	44	1,700	30	800	800	10	500	2,500	0.9	1.0	11	45
	7	10	28	62	132	52	2,400	34	800	800	10	700	3,300	1.2	1.4	16	45
Males	11	14	45	99	157	62	2,700	45	1,200	1,200	18	1,000	5,000	1.4	1.6	18	50
	15	18	66	145	176	69	2,800	56	1,200	1,200	18	1,000	5,000	1.4	1.7	18	60
	19	22	70	154	177	70	2,900	56	800	800	10	1,000	5,000	1.5	1.7	19	60
	23	50	70	154	178	70	2,700	56	800	800	10	1,000	5,000	1.4	1.6	18	60
	51+		70	154	178	70	2,400	56	800	800	10	1,000	5,000	1.2	1.4	16	60
Females	11	14	46	101	157	62	2,200	46	1,200	1,200	18	800	4,000	1.1	1.3	15	50
	15	18	55	120	163	64	2,100	46	1,200	1,200	18	800	4,000	1.1	1.3	14	60
	19	22	55	120	163	64	2,100	44	800	800	18	800	4,000	1.1	1.3	14	60
	23	50	55	120	163	64	2,000	44	800	800	18	800	4,000	1.0	1.2	13	60
	51+		55	120	163	64	1,800	44	800	800	10	800	4,000	1.0	1.2	13	60
Pregnant							+300	+30	+400	+400	<sup>5</sup> 18+	+200	+1,000	+0.4	+0.3	+2	+20
Lactating							+500	+20	+400	+400	18	+400	+2,000	+0.5	+0.5	+5	+40

1. Source: Adapted from Recommended Dietary Allowances, 9th ed., 1980, 185 pp. Washington D.C.: National Academy of Sciences, National Research Council. Also available in libraries. This publication tabulates the RDA for selected nutrients, discusses the basis for all RDA, and reviews current knowledge of the dietary needs for other nutrients.

2. 1 retinal equivalent = 0.1 µg retinol or 6 µg beta-carotene.

3. 1 international unit = 0.3 µg retinol or 0.6 µg beta-carotene.

4. After age 75 years, energy requirement is 2,050 calories for males and 1,600 calories for females.

5. The increased requirements cannot be met by ordinary diets, therefore the use of supplemental iron is recommended.

NOTE—The Recommended Daily Dietary Allowances (RDA) should not be confused with the U.S. Recommended Daily Allowances (U.S. RDA). The RDA are

amounts of nutrients recommended by the Food and Nutritional Board of the National Research Council and are considered adequate for maintenance of good nutrition in healthy persons in the United States. The allowances are revised from time to time in accordance with newer knowledge of nutritional needs.

The U.S. RDA are the amount of protein, vitamins, and minerals established by the Food and Drug Administration as standards for nutritional labeling. These allowances were derived from the RDA set by the Food and Nutritional Board. The U.S. RDA for most nutrients approximates the highest RDA of the sex-age categories in this table, excluding the allowances for pregnant and lactating females. Therefore, a diet that furnishes the U.S. RDA for a nutrient will furnish the RDA for more than the RDA for many U.S. RDA are protein, 45 grams (eggs, fish, meat, milk, poultry), 65 grams (other foods); vitamin A, 5,000 International Units; thiamin, 1.5 milligrams; riboflavin, 1.7 milligrams; niacin, 20 milligrams; ascorbic acid, 60 milligrams; calcium, 1 gram; phosphorus, 1 gram; iron, 18 milligrams. For additional information on U.S. RDA, see the "Federal Register," vol. 38 no. 49 (March 14, 1973), pp. 6959-6960, and Agriculture Information Bulletin 382, "Nutrition Labeling—Tools for Its Use."



# Use of Poultry Products

*Poultry Science, Level II*

## What Members Will Learn . . .

### ABOUT THE PROJECT:

- The difference between edible and nonedible poultry products
- Five edible uses of poultry products
- Five nonedible uses of poultry products
- Five nonedible uses of egg by-products

### ABOUT THEMSELVES:

- Their feelings about the value of poultry products in their daily lives
- Their feelings about the importance of recycling poultry wastes

### Materials Needed:

- Magazines and newspapers containing advertisements that depict different poultry products

**ACTIVITY TIME NEEDED:** 45 MINUTES

## ACTIVITY

## Leader Notes

---

Poultry products are either **edible** (fit for human consumption) or **nonedible** (not fit for human consumption). Although eggs and poultry meat are major parts of the human diet, we also benefit from many nonedible products that are produced by the poultry industry.

### EDIBLE PRODUCTS

Eggs and poultry meat are classified as a protein food. About 80 percent of the eggs consumed in the United States are purchased as shell eggs and served in the fried, hard cooked, or scrambled forms. The other 20 percent are used in a wide range of food products because of the **functional** properties that they add to foods. Egg white is used in pie meringues and in angel food cakes because of its **leavening** property, or its ability to make things rise. The egg yolk is used in meatloaf and in coatings on fried chicken because of its **binding** ability. Egg yolk is used in mayonnaise because it adds a natural yellow **color** to the product and because it contains an **emulsifying** agent that keeps the oil and water from separating. Lastly, the egg is used in foods because of its excellent **nutritional** value.

Poultry meat is a very popular item in the American diet because it is economical, highly nutritious, and available in many different forms such as parts, ground turkey, breast fillets, etc. These are called **value-added** or **further-processed** products because the processor has increased the product's value by increasing the convenience of their preparation.

### NONEDIBLE PRODUCTS

Many nonedible products produced by the poultry industry benefit people. Although some of these products are still wasted, the industry is making progress in using them.

**Poultry manure** at the present time presents a challenge to the industry. Urbanization, increase in size of production units, and danger of pollution make disposal of manure a challenge. Manure can be used as a fertilizer, a feed ingredient, and in the production of methane gas.

**Feathers** are used for livestock feed, ornaments, some sporting equipment (arrows), bedding (down-filled blankets), and clothing. **Offal** which consists of the heads, feet, and nonedible internal organs is used in various types of feed. **Blood** can be used for fish bait, fertilizer, and feed. **Grease** extracted from the offal is used in feed.

Do at least one of the following activities with your group: (1) visit a supermarket and record as many items as you can that contain poultry products, (2) prepare a scrapbook of product labels or advertisements of edible and nonedible poultry product uses; or (3) compare the price per pound of a whole broiler or turkey to that of ground chicken or turkey, chicken patties, or chicken or turkey frankfurters. Discuss reasons for differences in prices.

Nonedible by-products from eggs have many uses. The most significant use of eggs other than for human food is for **reproduction**. Other uses are: the addition of nonedible eggs in **pet foods**; the production of biological products such as **vaccines** and **growth media** for microorganisms; the use of egg yolk in **preservation of sperm, tanning of leather, shampoos and lotions**; the use of egg white in **adhesives**; and the use of the intact egg shell as an **art medium**.

### DIALOGUE FOR CRITICAL THINKING

1. What activity did you choose? Why?
2. What was the most unusual or interesting thing you learned from your activity?
3. What was the most difficult part of completing the activity?
4. How many of the products do you use?
5. How did you decide to use these products? Why?
6. What products do you feel you will use in the future that you do not currently use? Why?
7. Why do you think the poultry industry tries to find as many uses as possible for its products?
8. As a consumer rather than a producer, how can you cut down on waste in your life?

### GOING FURTHER

1. Study recycling aspects of poultry manure and share with your group and others.
2. Explore how poultry manure is used to produce methane gas.
3. Give a presentation on uses of feathers and show examples.
4. Give a presentation on egg by-products and their value to humans.
5. Have someone demonstrate the use of an egg shell as an art form.



Adapted from a Kansas State University Cooperative Extension Service publication written by Cynthia R Siemens and reviewed by James P. Adams and Albert W. Adams, All from KSU.

Revised for Washington State by Jerry A. Newman, 4-H Youth Development Specialist.



4-H 

WASHINGTON STATE UNIVERSITY  
EXTENSION

Copyright 2014 Washington State University

WSU Extension bulletins contain material written and produced for public distribution. Alternate formats of our educational materials are available upon request for persons with disabilities. Please contact Washington State University Extension for more information.

You may download copies of this and other publications from WSU Extension at <http://pubs.wsu.edu>. Issued by Washington State University Extension and the U.S. Department of Agriculture in furtherance of the Acts of May 8 and June 30, 1914. Extension programs and policies are consistent with federal and state laws and regulations on nondiscrimination regarding race, sex, religion, age, color, creed, and national or ethnic origin; physical, mental, or sensory disability; marital status or sexual orientation; and status as a Vietnam-era or disabled veteran. Evidence of noncompliance may be reported through your local WSU Extension office. Trade names have been used to simplify information; no endorsement is intended. Published July 1998. Revised October 2014. *This publication replaces EM4887.*