

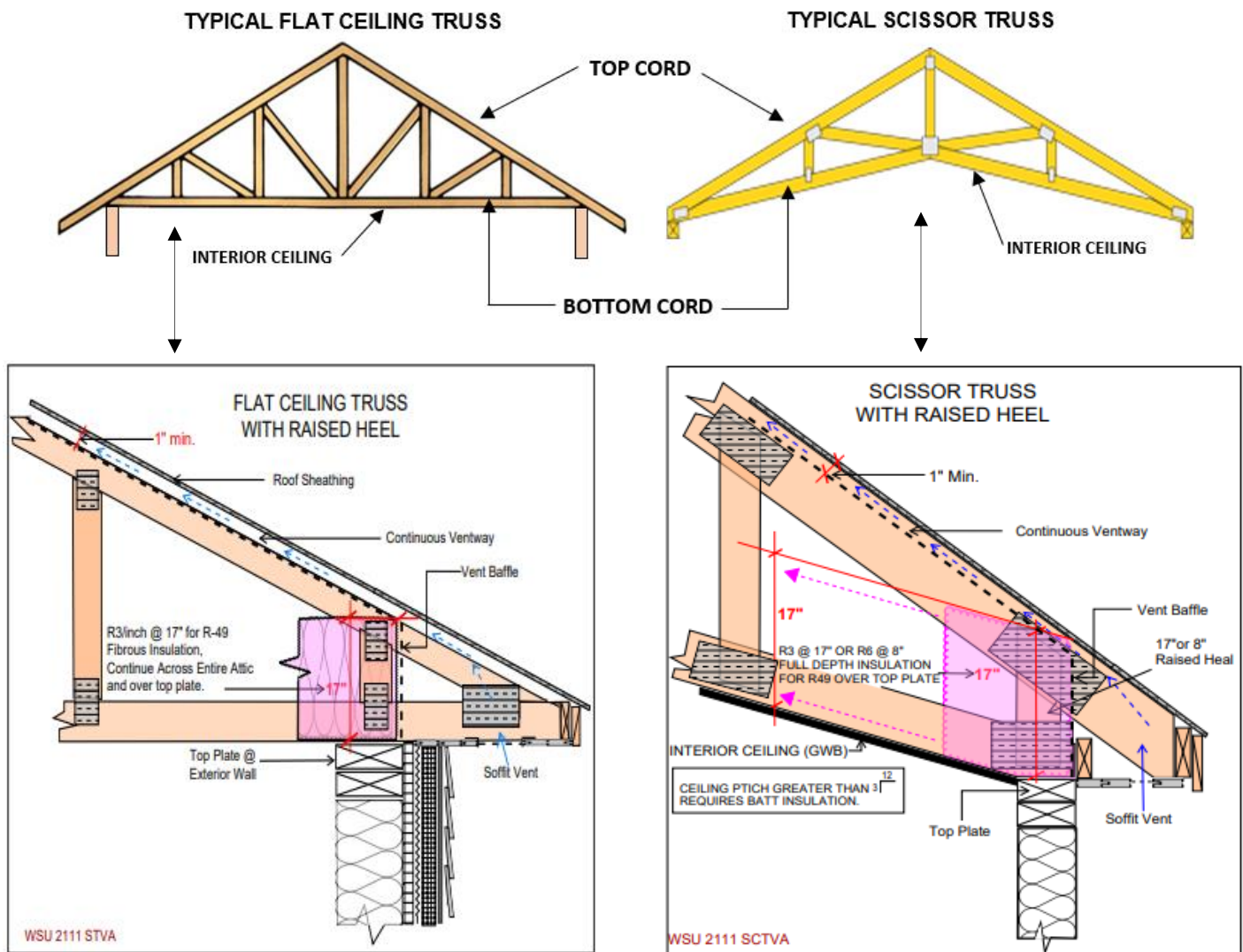

Is R60 the requirement for meeting the 2021 Residential Energy Code?

The 2021 Washington State Residential Energy Code, (WSEC-R) permits designers to select between several alternatives that comply with roof and attic insulation. Where Section **R402.1.3** requires R-60 in the ceiling or attic the code also allows R-49 to be installed over the entire, (100%) of the ceiling area and “wherever the full height of uncompressed R-49 insulation extends over the wall top plate at the eaves.” This applies to standard trusses with flat ceilings as well as scissor trusses.

R402.2.1 Ceilings with attic spaces. Where Section R402.1.3 would require R-60 in the ceiling or attic, installing R-49 over 100 percent of the ceiling area requiring insulation shall satisfy the requirement for R-60 wherever the full height of uncompressed R-49 insulation extends over the wall top plate at the eaves. This reduction shall not apply to the insulation and fenestration criteria in Section R402.1.2 and the Total UA alternative in Section R402.1.5.



R303.1.1.1 Blown or sprayed roof/ceiling insulation. The thickness of blown-in or sprayed roof/ceiling insulation (fiberglass or cellulose) shall be written in inches (mm) on markers that are installed at least one for every 300 square feet (28 m²) throughout the attic space. The markers shall be affixed to the trusses or joists and marked with the minimum initial installed thickness with numbers a minimum of 1 inch (25 mm) in height.

R402.2.1.1 Loose fill insulation in attic spaces. Open-blown or poured loose fill insulation may be used in attic spaces where the slope of the ceiling is not more than 3 feet in 12 and there is at least 30 inches of clear distance from the top of the bottom chord of the truss or ceiling joist to the underside of the sheathing at the roof ridge.

R402.2.3 Eave baffle. For air-permeable insulation in vented attics, a baffle shall be installed adjacent to soffit and eave vents. Baffles shall maintain a net free area opening equal to or greater than the size of the vent. The baffle shall extend over the top of the attic insulation. The baffle shall be permitted to be any solid material. The baffle shall be installed to the outer edge of the exterior wall top plate so as to provide maximum space for attic insulation coverage over the top plate. Where soffit venting is not continuous, baffles shall be installed continuously to prevent ventilation air in the eave soffit from bypassing the baffle.

What about Vaulted Ceilings? Do Vaulted Ceilings require R60 or R49 also?

The WSEC-R describes a Vaulted Ceiling / Roof Assembly as a “single rafter or joist-vaulted ceiling” where the roof and ceiling are parallel, i.e., the roof slope or pitch is the same as the interior ceiling slope or pitch. For Vaulted Assemblies, “the insulation may be reduced to R-38 if the full insulation depth extends over the top plate of the exterior wall.” Vaulted Assemblies may be vented or unvented. The roof structure may be constructed with any type of assembly that provides a parallel slope at both the interior and exterior surfaces. Refer back to the scissor truss image above to compare with the images below.

TYPICAL EXAMPLES OF MATERIALS USED TO CREATE VAULTED ROOF ASSEMBLIES

MANUFACTURED LUMBER
TJI, BCI, ETC.

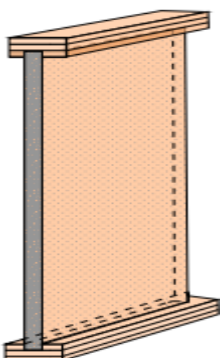

DIMENSIONAL LUMBER
2X, 4X, ETC.

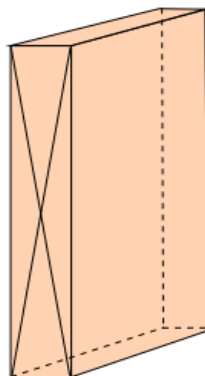

PARALLEL CORD TRUSS

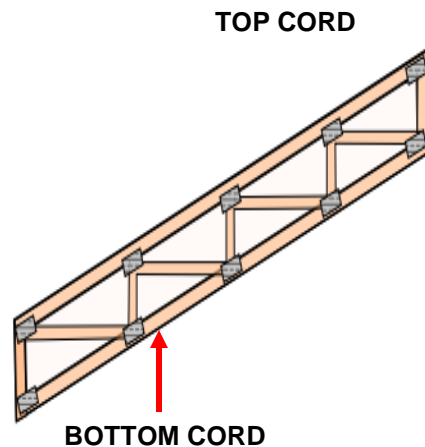

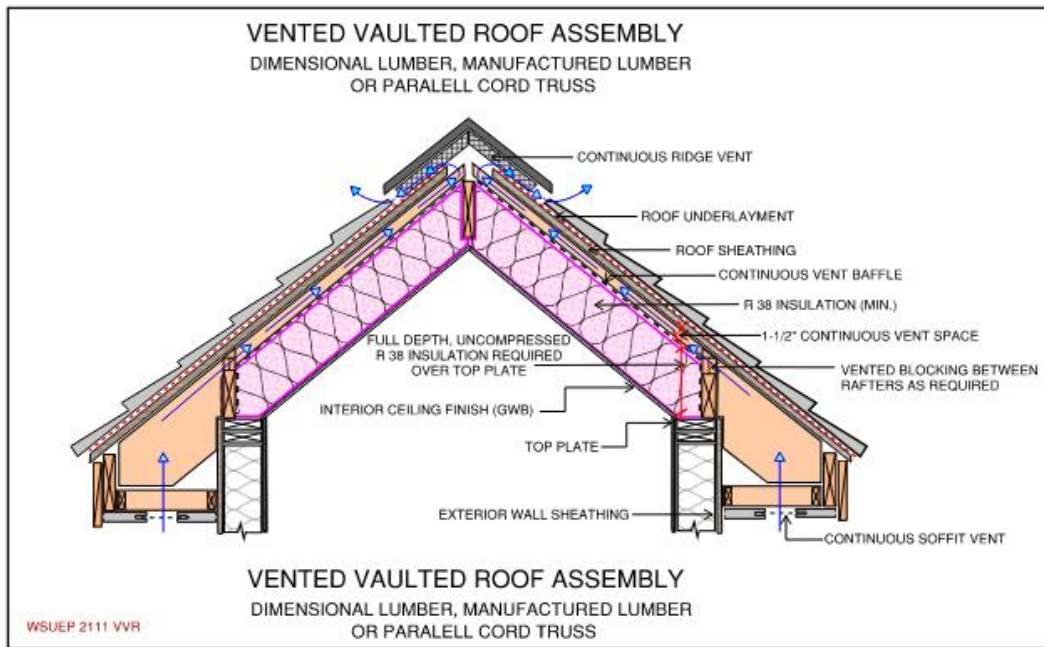

Appendix A102.2.2 Vaulted ceilings. Insulation is assumed to be fiberglass batts installed in roof joist cavities. In the vented case, at least 1.5 inches between the top of the batts and the underside of the roof sheathing is left open for ventilation in each cavity. A ventilation rate of 3.0 air changes per hour is assumed. In the unvented or dense pack case, the ceiling cavity is assumed to be fully packed with insulation, leaving no space for ventilation.

Appendix A102.2.3 Roof decks. Rigid insulation is applied to the top of roof decking with no space left for ventilation. Roofing materials are attached directly on top of the insulation. Framing members are often left exposed on the interior side.

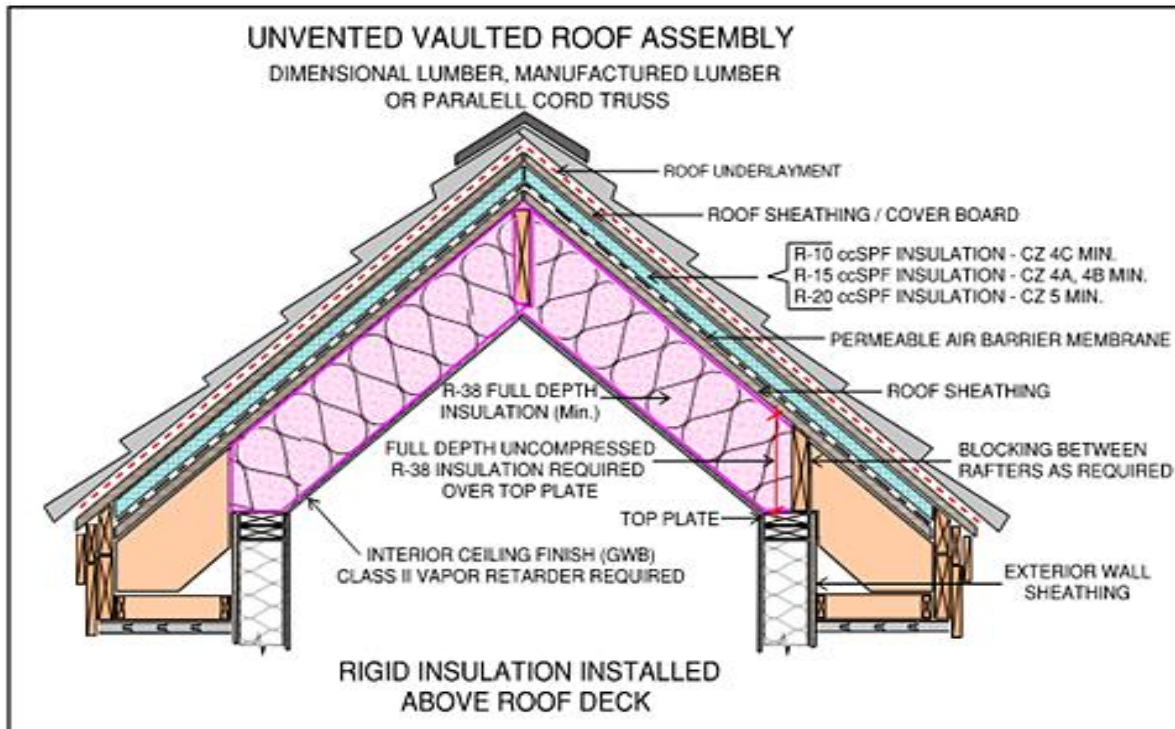

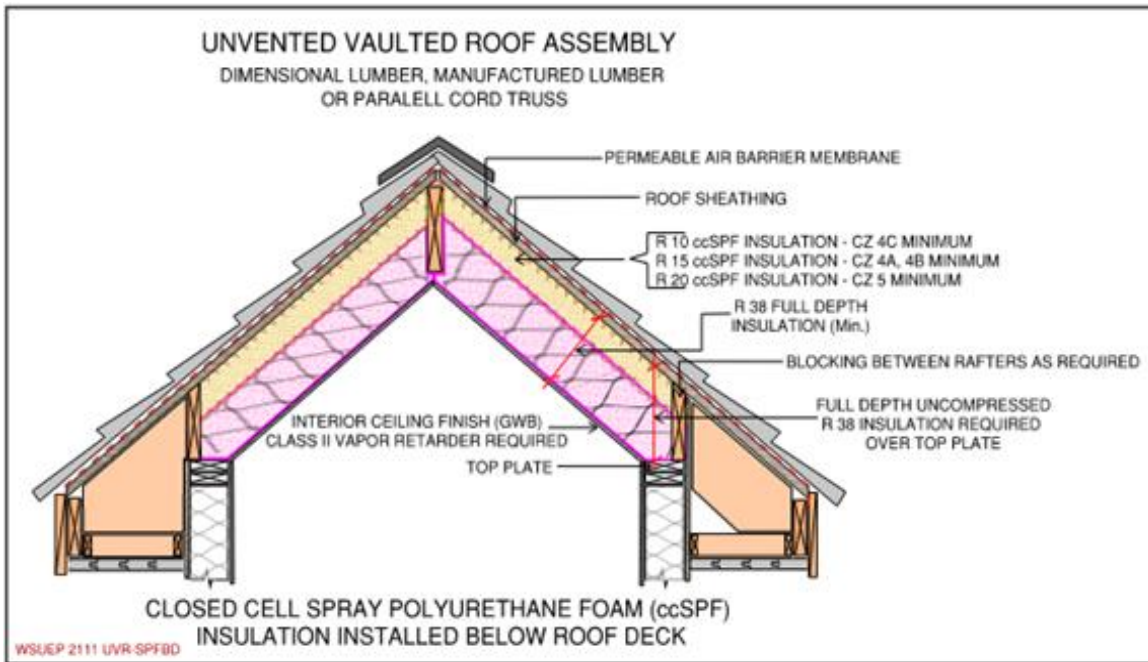

Options for Installing High R-Value Insulation over the Top Plate to Install a Lower Raised Heel

At times there may be an opportunity or reason to decrease the height of the raised heel truss. This can be useful to lower the cost of a tall raised heel trusses or it may be to reduce the height of the building due to zoning height restrictions or maybe you are designing an addition where its roof wants to line up with the existing roof. Whatever the reason, installing a high R-Value material over the top plate may be the trick. High R per inch materials may be installed reducing the height of the raised heel and allowing lessor cost insulation, i.e., blown in fibrous or batt insulation, to be installed over the balance of the ceiling insulation. The two examples below illustrate R-6+ Closed Cell Spray Foam and R-6+ Polyisocyanurate rigid foam board. Both flat ceiling and scissor trusses may accommodate either material.

Options for installing a reduced height, raised heel truss by using Closed Cell Spray Polyurethane Foam, (ccSPF) or rigid foam board, (Polyisocyanurate) over the top plate. Continue with additional insulation over the entire attic. The same method may be applied with a scissor truss.

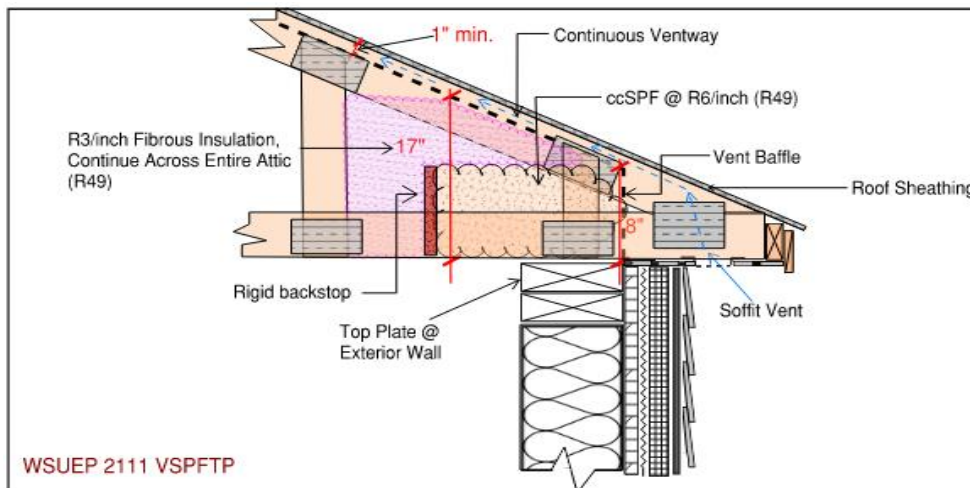

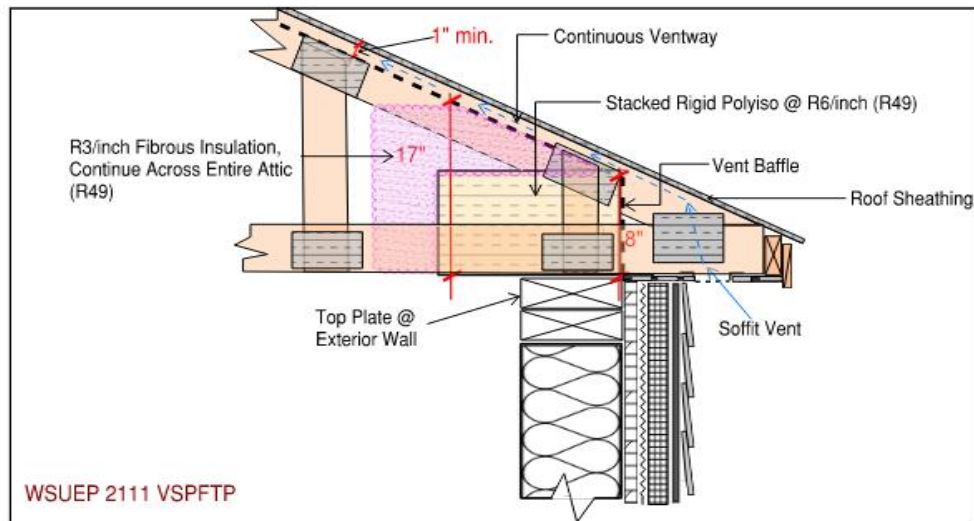

**TABLE R402.1.3
INSULATION MINIMUM R-VALUES AND FENESTRATION REQUIREMENTS BY COMPONENTS***

CLIMATE ZONE 5 AND MARINE 4	
Fenestration U-Factor ^{b, j}	0.30
Skylight ^b U-Factor	0.50
Ceiling R-Value ^e	60
Wood Frame Wall ^{g, i} R-Value	20+5 or 13+10
Floor R-Value	30
Below-Grade ^{c, h} Wall R-value	10/15/21 int + 5TB
Slab ^{d, f} R-Value & Depth	10, 4 ft

e. For single rafter or joist vaulted ceilings the insulation may be reduced to R-38 if the full insulation depth extends over the top plate of the exterior wall.

The 2021 Washington State Residential Code includes specific rules for unvented attic and unvented enclosed rafter assemblies. Section R806.5 and Table R806.5 provide the requirements.

TABLE R806.5 INSULATION FOR CONDENSATION CONTROL*

CLIMATE ZONE	MINIMUM RIGID BOARD ON AIR-IMPERMEABLE INSULATION R-VALUE ^{a, b}
2B and 3B tile roof only	0 (none required)
1, 2A, 2B, 3A, 3B, 3C	R-5
4C	R-10
4A, 4B	R-15
5	R-20
6	R-25
7	R-30
8	R-35

a. Contributes to but does not supersede the requirements in [Section N1102](#)

b. Alternatively, sufficient continuous insulation shall be installed directly above the structural roof sheathing to maintain the monthly average temperature of the underside of the structural roof sheathing above 45°F (7°C). For calculation purposes, an interior air temperature of 68°F (20°C) is assumed and the exterior air temperature is assumed to be the monthly average outside air temperature of the three coldest months.

* TABLE 806.5, 2021 Washington State Residential Code

**TABLE R402.4.1.1
AIR BARRIER, AIR SEALING AND INSULATION INSTALLATION^a**

COMPONENT	AIR BARRIER CRITERIA	INSULATION CRITERIA
Ceiling/attic	The air barrier in any dropped ceiling/soffit shall be aligned with the insulation and any gaps in the air barrier sealed. Access openings, drop down stair or knee wall doors to unconditioned attic spaces shall be sealed.	The insulation in any dropped ceiling/soffit shall be aligned with the air barrier Batt insulation installed in attic roof assemblies may be compressed at exterior wall lines to allow for required attic ventilation.

**SECTION A102
CEILINGS**

A102.2 Component description. The four types of ceilings are characterized as follows:

A102.2.1 Ceilings below a vented attic.

Attic insulation is assumed to be blown-in, loose-fill fiberglass with a K-value of 2.6 h × ft² • °F/Btu per inch. Full bag count for specified R-value is assumed in all cases. Ceiling dimensions for flat ceiling calculations are 45 by 30 feet, with a gabled roof having a 4/12 pitch. The attic is assumed to vent naturally at the rate of 3 air changes per hour through soffit and ridge vents. A void fraction of 0.002 is assumed for all attics with insulation baffles. Standard-framed, un baffled attics assume a void fraction of 0.008.

Attic framing is either standard or advanced. Standard framing assumes tapering of insulation depth around the perimeter with resultant decrease in thermal resistance. An increased R-value is assumed in the center of the ceiling due to the effect of piling leftover insulation. Advanced framing assumes full and even depth of insulation extending to the outside edge of exterior walls. Advanced framing does not change from the default value. U-factors for flat ceilings below vented attics with standard framing may be modified with the following table:

Roof Pitch	U-factor for Standard Framing	
	R-30	R-38
4/12	0.036	0.031
5/12	0.035	0.030
6/12	0.034	0.029
7/12	0.034	0.029
8/12	0.034	0.028
9/12	0.034	0.028
10/12	0.033	0.028
11/12	0.033	0.027
12/12	0.033	0.027

A102.2.2 Vaulted ceilings. Insulation is assumed to be fiberglass batts installed in roof joist cavities. In the vented case, at least 1.5 inches between the top of the batts and the underside of the roof sheathing is left open for ventilation in each cavity. A ventilation rate of 3.0 air changes per hour is assumed. In the unvented or dense pack case, the ceiling cavity is assumed to be fully packed with insulation, leaving no space for ventilation.

A102.2.3 Roof decks. Rigid insulation is applied to the top of roof decking with no space left for ventilation. Roofing materials are attached directly on top of the insulation. Framing members are often left exposed on the interior side.

Vented scissors truss attics assume a ceiling pitch of 2/12 with a roof pitch of either 4/12 or 5/12. Un baffled standard framed scissors truss attics are assumed to have a void fraction of 0.016.

A102.2.6 Roofs with insulation entirely above deck (uninterrupted by framing).

Table A102.2.6(1) through A102.2.6(3): The base assembly is continuous insulation over a structural deck. These tables indicate effective U-factors for tapered roof insulation, sloped from a maximum R-value (Rmax) at the peak of the slope to a minimum R-value (Rmin) at the low point of the slope. The rows of the tables represent the rated R-value of the

insulation at the minimum conditions (except at roof drains) and the columns of the table represent the rated R-value of the insulation at the maximum conditions. The slope of the tapered insulation shall be no greater than 1/4 inch per foot.

**TABLE A102.1
DEFAULT U-FACTORS FOR CEILINGS**

	Standard Frame	Advanced Frame
Ceilings Below Vented Attics		
Flat	Baffled	
R-19	0.049	0.047
R-30	0.036	0.032
R-38	0.031	0.026
R-49	0.027	0.020
R-60	0.025	0.017
Scissors Truss		
R-30 (4/12 roof pitch)	0.043	0.031
R-38 (4/12 roof pitch)	0.040	0.025
R-49 (4/12 roof pitch)	0.038	0.020
R-30 (5/12 roof pitch)	0.039	0.032
R-38 (5/12 roof pitch)	0.035	0.026
R-49 (5/12 roof pitch)	0.032	0.020
Vaulted Ceilings		
	16" O.C.	24" O.C.
Vented		
R-19 2x10 joist	0.049	0.048
R-30 2x12 joist	0.034	0.033
R-38 2x14 joist	0.027	0.027
Unvented		
R-30 2x10 joist	0.034	0.033
R-38 2x12 joist	0.029	0.027
R-21 + R-21 2x12 joist	0.026	0.025
Roof Deck		
	4x Beams, 48" O.C.	
R-12.5 2" Rigid insulation	0.064	
R-21.9 3.5" Rigid insulation	0.040	
R-37.5 6" Rigid insulation	0.025	
R-50 8" Rigid insulation	0.019	

Disclaimer:

Our WSEC-Residential technical support team is not an affiliate of, nor do we speak for, the Washington State Building Code Council (SBCC). Official opinions of WSEC intent are made only by the SBCC in response to official inquiries submitted to the SBCC by authorities having jurisdiction. While we try to stay aligned with the SBCC, the technical support we provide is advisory only and non-binding on authorities having jurisdiction, builders, designers, and the building trades personnel involved with construction and remodeling of residential structures.